

PLASTIC PARTS

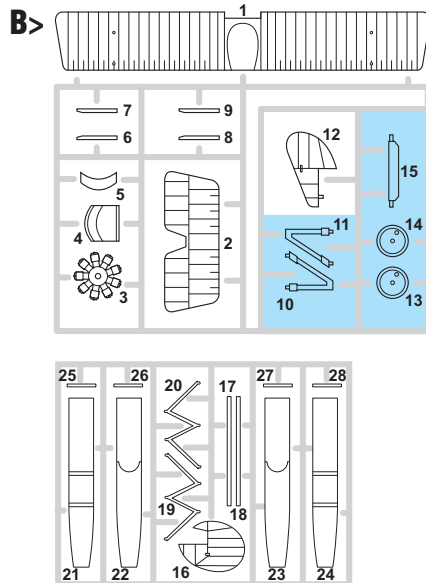

CP - CLEAR PART

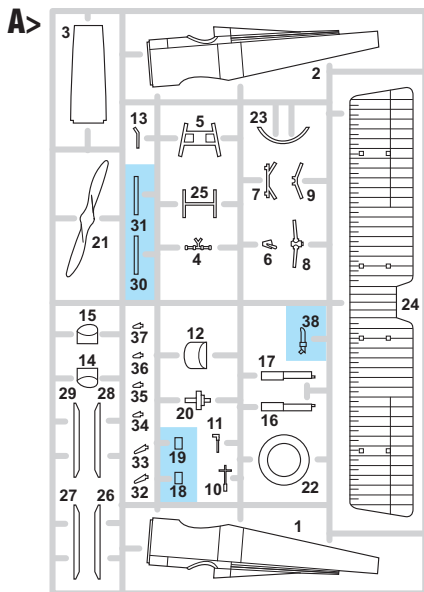

GUNZE	MISSION MODELS	
H12	C33	MMP-047 FLAT BLACK
H37	C43	WOOD BROWN
H85	C45	SAIL COLOR
H337	C337	GRAYISH BLUE
MATERIAL COLOR	METALLICS	
MC214	MMM-001	DARK IRON
MC218	MMM-003	ALUMINIUM

-Parts not for use. -Teile werden nicht verwendet. -Pièces à ne pas utiliser. -Tyto díly nepoužívejte při stavbě. - 使用しない部品

ATTENTION * UPOZORNĚNÍ * ACHTUNG * ATTENTION

- (GB)** Carefully read instruction sheet before assembling. When you use glue or paint, do not use near open flame and use in well ventilated room. Keep out of reach of small children. Children must not be allowed to suck any part, or pull vinyl bag over the head.
- (CZ)** Před započatím stavby si pečlivě prostudujte stavební návod. Při používání barev a lepidel pracujte v dobře větrané místnosti. Lepidla ani barvy nepoužívejte v blízkosti otevřeného ohně. Model není určen malým dětem, mohlo by dojít k požití drobných dílů.
- (D)** Vor dem Zusammenbau die Bauanleitung gut durchlesen. Kleber und Farben nicht in der Nähe von offenem Feuer verwenden und für eine ausreichende Belüftung sorgen. Den Bausatz von kleinen Kindern fernhalten. Vermeiden Sie, dass Kinder Bauteile in den Mund nehmen oder sich Plastiktüten über den Kopf ziehen.
- (F)** lire soigneusement la fiche d'instructions avant d'assembler. Ne pas utiliser de colle ou de peinture à proximité d'une flamme nue, et aérer la pièce de temps en temps. Garder hors de portée des enfants en bas âge. Ne pas laisser les enfants mettre en bouche ou sucer les pièces, ou passer un sachet vinyl sur la tête.

INSTRUCTION SIGNS * INSTR. SYMBOLY * INSTRUKTION SINNBILDEN * SYMBOLES

- (?)** OPTIONAL VOLBA
- (↻)** BEND OHNOUT
- (⊘)** OPEN HOLE VYVRTAT OTVOR
- (↔)** SYMETRICAL ASSEMBLY SYMETRICKÁ MONTÁŽ
- (✂)** REMOVE ODŘÍZNOUT
- (⊖)** REVERSE SIDE OTOČIT

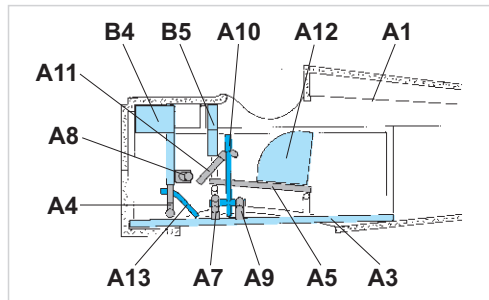
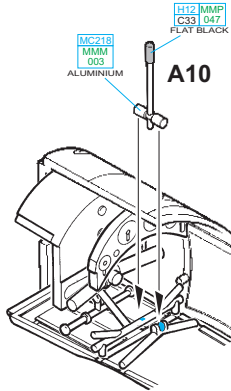
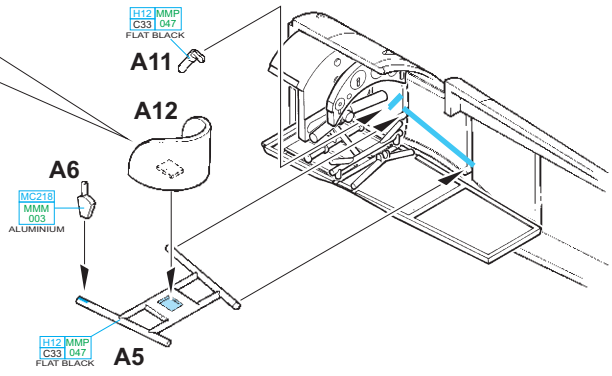
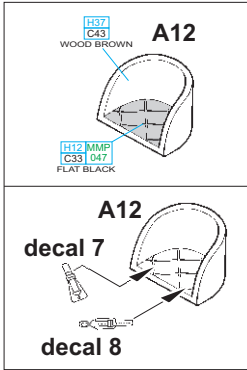
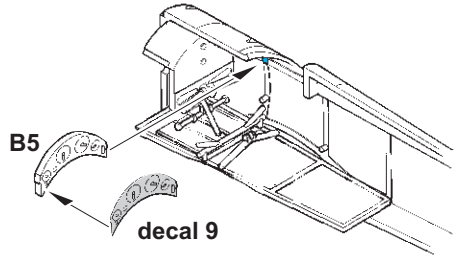
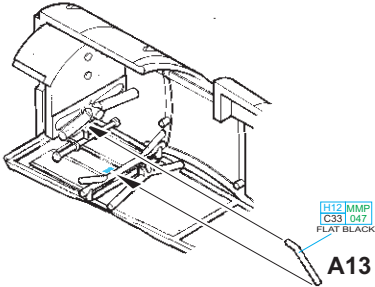
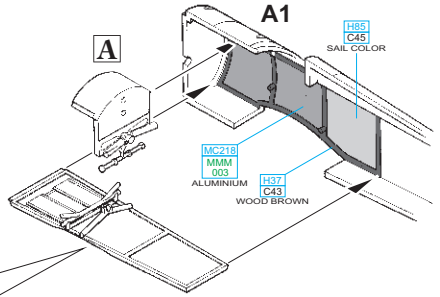
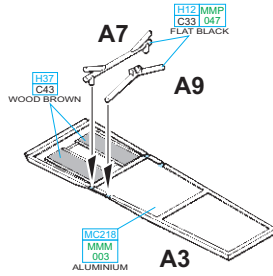
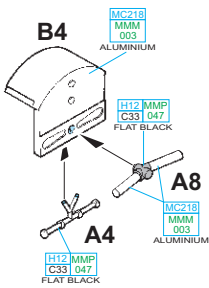
A

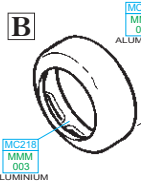
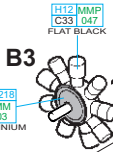
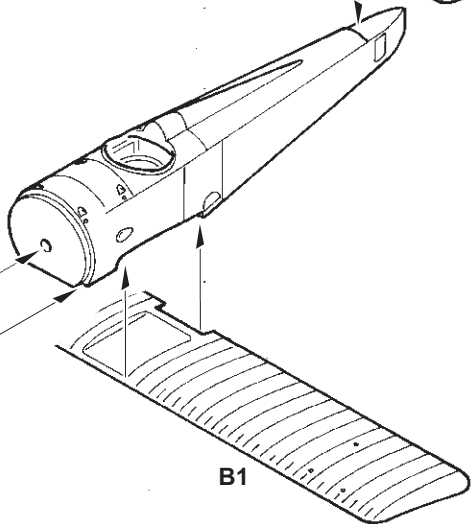
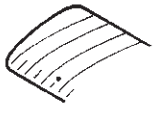
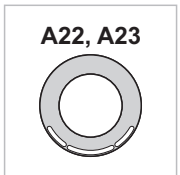
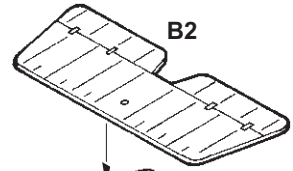
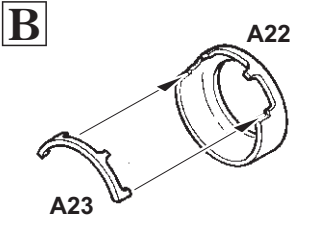
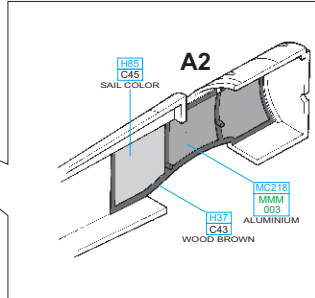
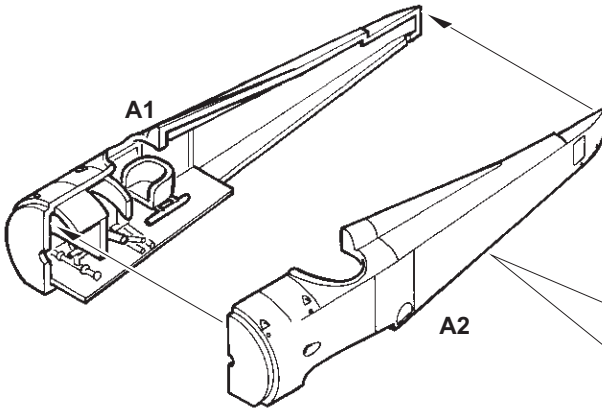

A34, A35, B16 - **MARKING B** A36, A37, B12 - **MARKING A**

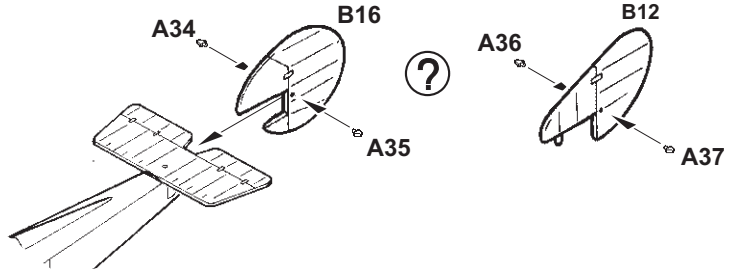

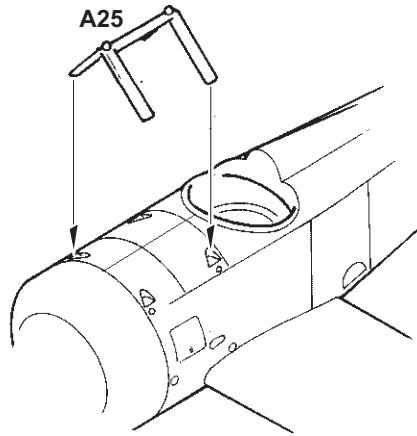

∅ - 0,5 mm

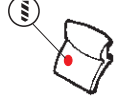

MC218
MMM
003
ALUMINIUM

A15



MC214
MMM
001
DARK IRON

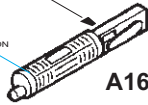

A17



MC214
MMM
001
DARK IRON

∅ - 0,5 mm



A14

MC218
MMM
003
ALUMINIUM

CP1

MC218
MMM
003
ALUMINIUM

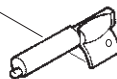
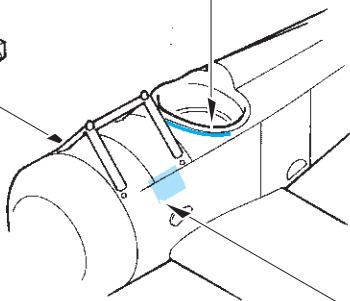
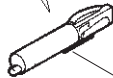

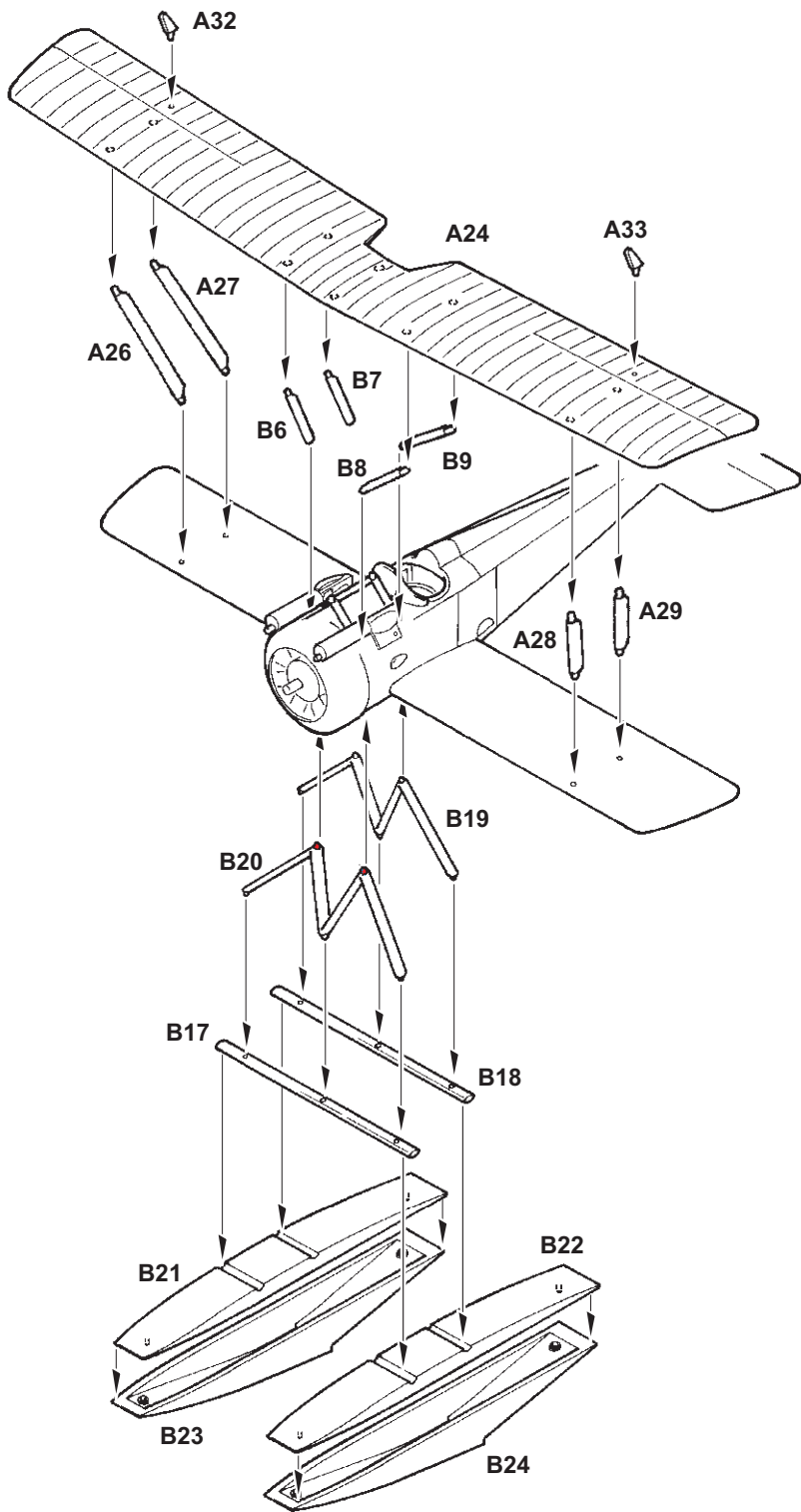

MARKING A

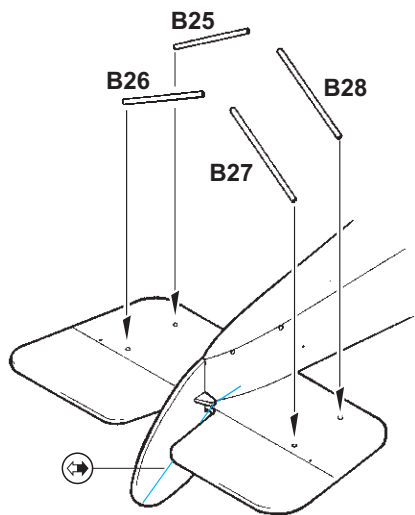

MARKING B

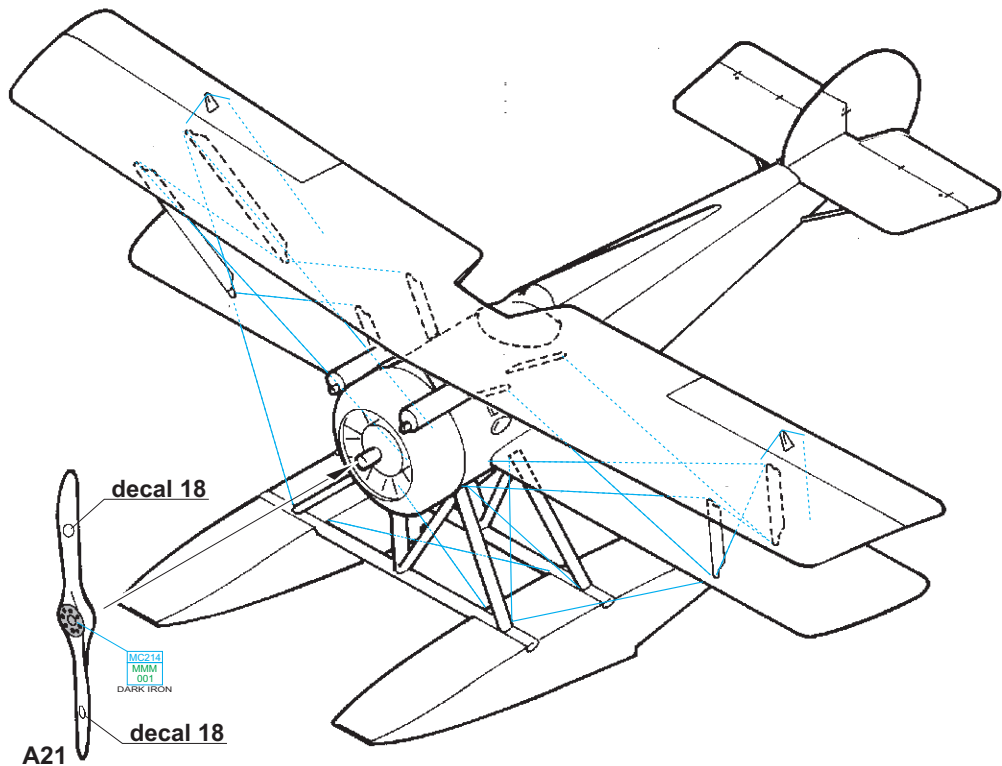
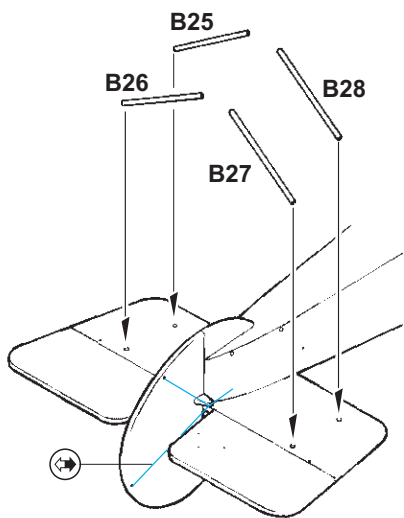

A No. 226, Centre d'Aviation Maritime, Dunkerque, France, October 1917 – May 1918

First HD.2 airframes were delivered in October 1917 to Centre d'Aviation Maritime (CAM) based in Dunkerque. Unit's main task were escorts of the FBA and Donnet-Denhaut flying boats on their anti-submarine sorties. On May 4th, 1918, five HD.2 aircraft were jumped by six Albatros D.IIIs from Marine Feldjagdstaffel 1 based on the airport nearby Nieuwmunster in Belgium. Two French aircraft were shot down, one of them was the plane carrying number 226 and D-30 marking piloted by Maitre Le Creuer who was captured but later succumbed to his injuries. Engine cowling and the fuselage front part remained in the natural metal color, the rest of the "naval" Hanriot surfaces were painted in bluish-grey color. Marking of the aircraft belonging to this unit consisted of the letter D with the number from the 20-39 range and painting of a swallow.

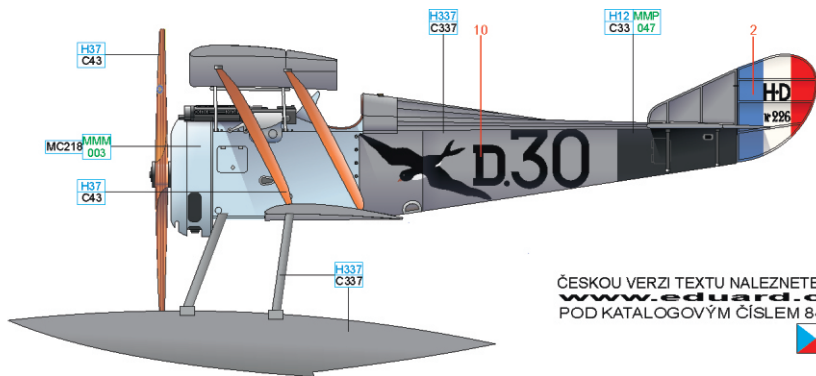

ČESKOU VERZI TEXTU NALEZNETE NA
www.eduard.cz
POD KATALOGOVÝM ČÍSLEM 8413

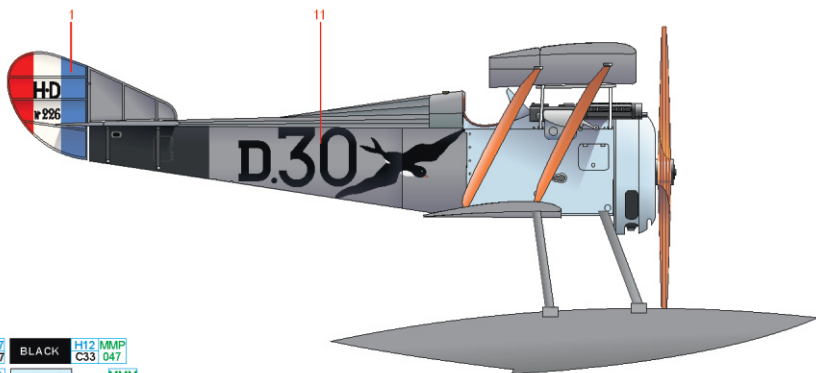
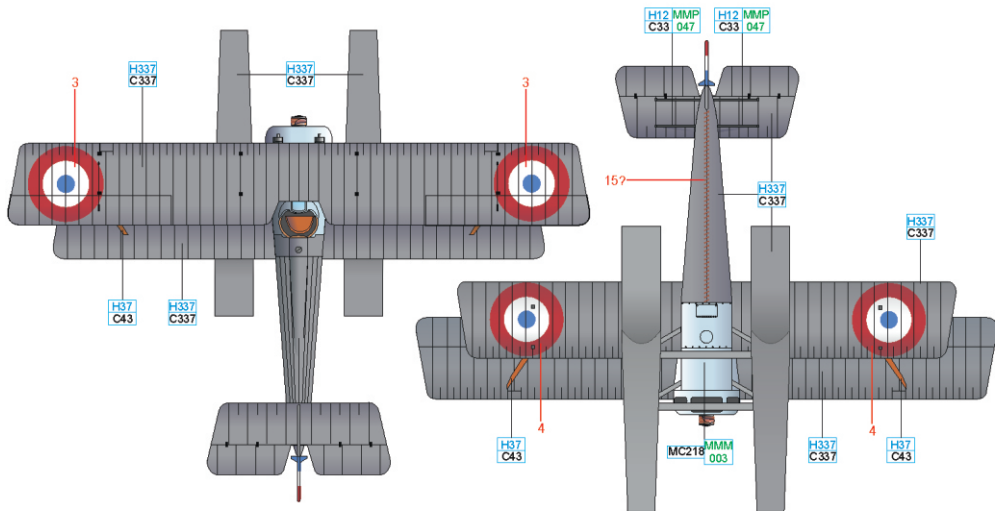

GRAYISH BLUE	H337 C337	BLACK	H12 MMP C33 047
WOOD	H37 C43	ALUMINIUM	MC218 MMM 003

B U. S. Navy contingent in France, Dunkerque, France, spring 1918

First Hanriots HD.2 were received by the U.S. Navy contingent in December 1917, first of the approximately 500 combat flight was performed on May 5th, 1918. Same as in the French unit, these planes flew the flying boats escorts on their anti-submarine missions. Same as the Hanriots HD.2 flying with French Naval Aviation the aircraft serving with the U.S. Navy in France were painted in bluish-gray color, front of the fuselage and the engine cowling remained in the natural metal color.

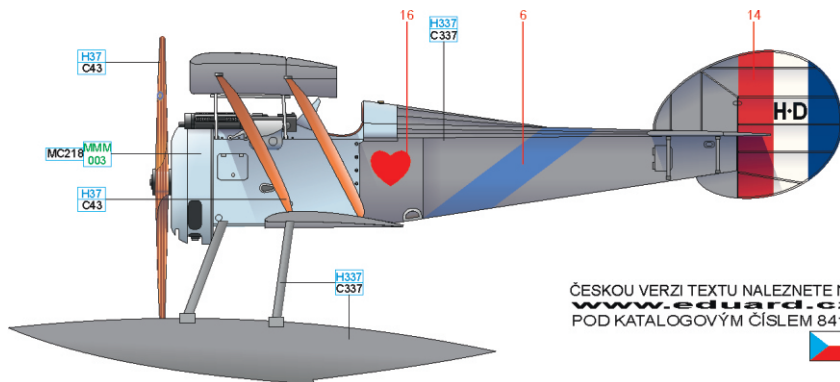

ČESKOU VERZI TEXTU NALEZNETE NA
www.eduard.cz
 POD KATALOGOVÝM ČÍSLEM 8413

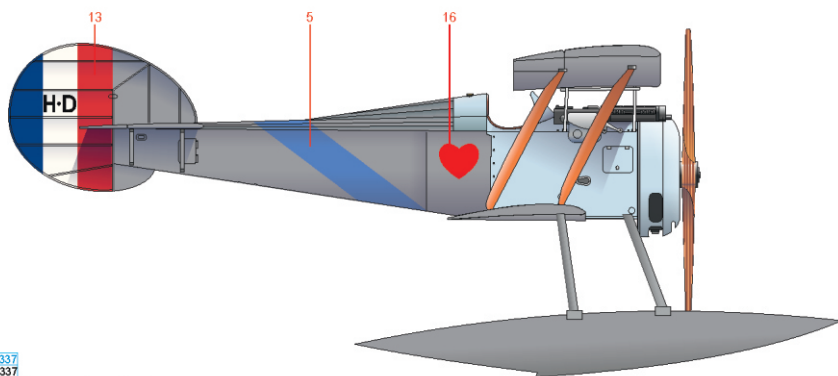
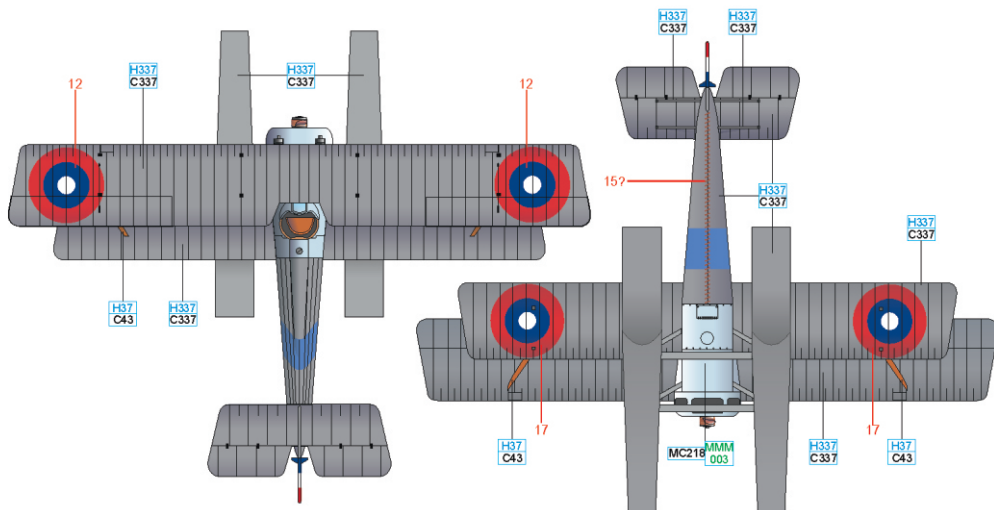

GRAYISH BLUE H337 C337

WOOD H37 C43

ALUMINIUM MC218 MMM 003