

fündekals :)

www.fundekals.com

CHANCE VOUGHT



F4U CORSAIRS

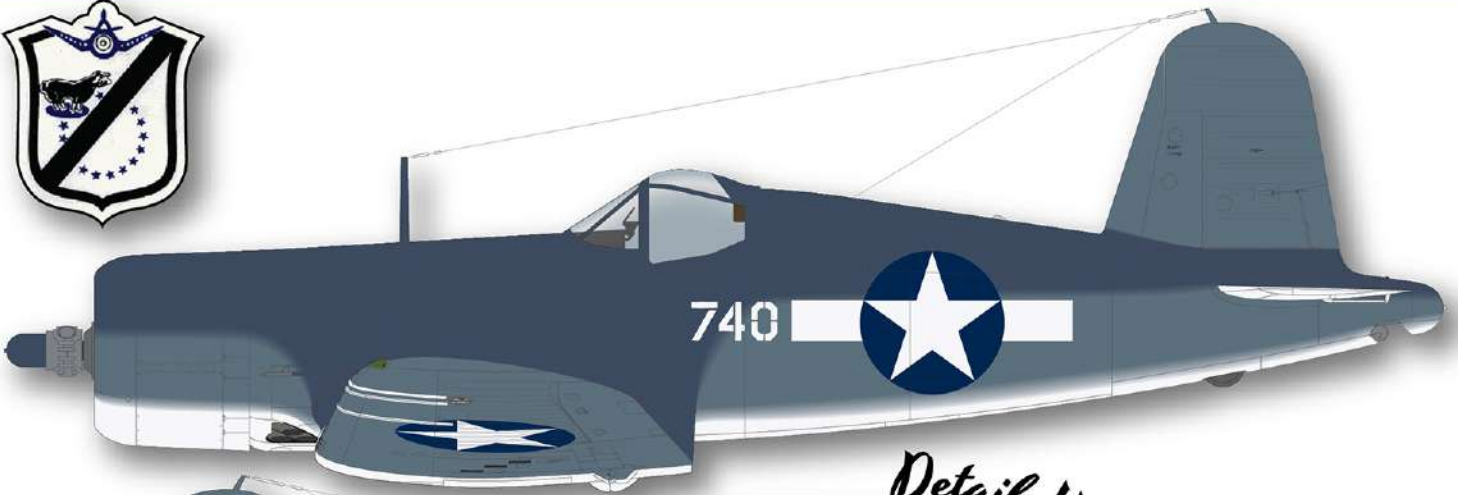

Detail Note

We can't explain this light colored patch on the spine. See photographs.

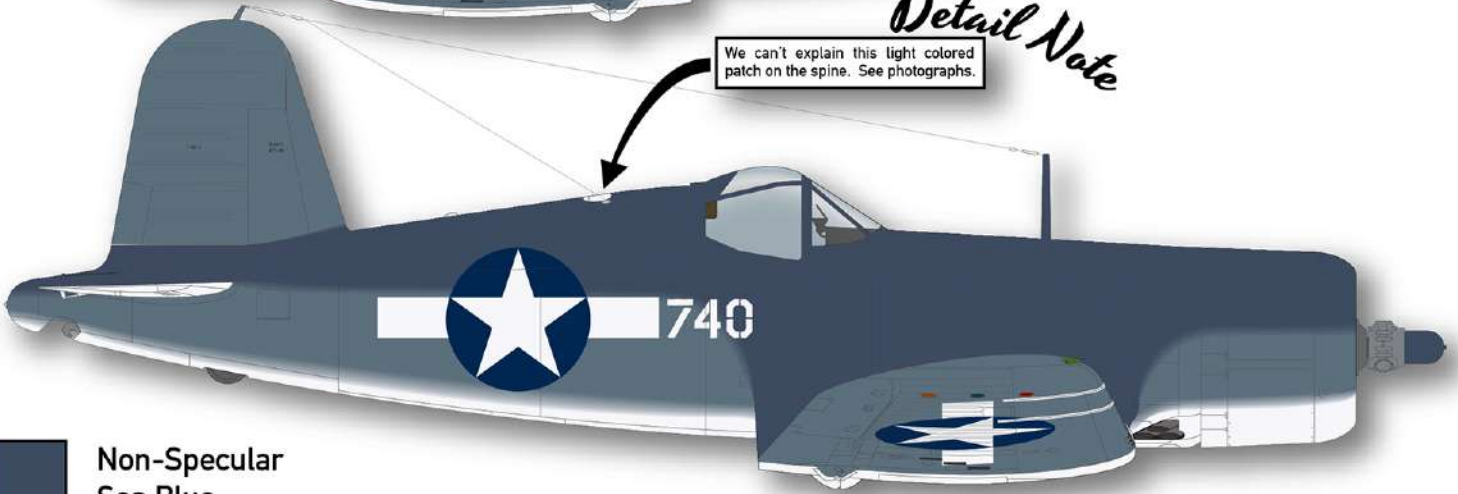

■ Non-Specular
Sea Blue

■ Non-Specular
Intermediate Blue

■ Non-Specular
White

Detail Note

See the page on F4U
antenna configurations for
details on the antenna fit.

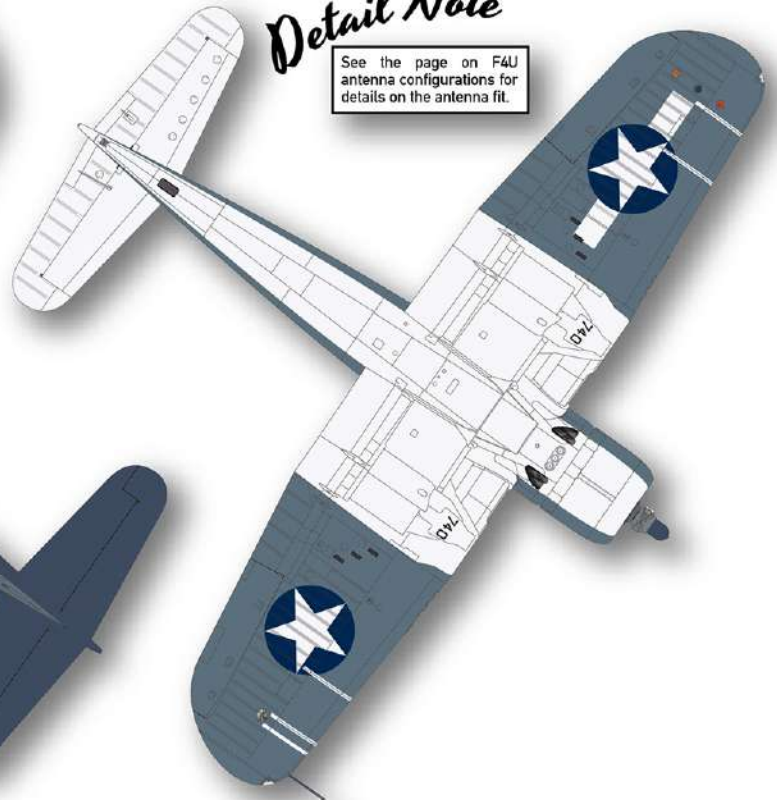
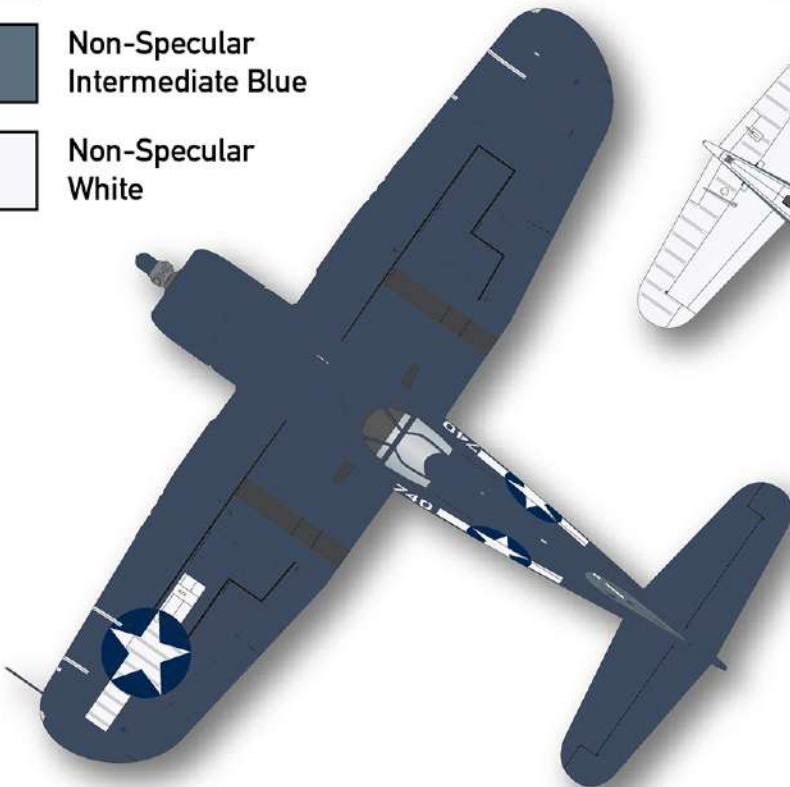

For the better part 1943 and well into 1944, fighter squadrons of the 2nd MAW (Marine Air Wing) were taking part in combat operations "up the slot" in the Solomons campaign. Missions centered around gaining control of the air over the major Japanese bases at Rabaul and Bougainville. During this period VMFs took their aircraft from a pool assigned to the MAG. Aircraft were not assigned to individual squadrons or pilots, and whatever was available is what was flown on a given mission. We bring this up in order to demonstrate that the first four USMC Corsairs on this sheet probably did not even "belong" to an individual squadron, let alone an individual pilot.

Our first example is F4U-1A BuNo 17740, which has long been associated with Major Gregory "Pappy" Boyington of VMF-214. This is largely due to a series of photos taken on 4 December 1943 at Vella Lavella. The pictures capture the exchange of baseball equipment from the St Louis Cardinals for "kills" from VMF-214. It is likely that several of the nine aces from VMF-214's second deployment flew this Corsair, but we were unable to confirm a single kill for '740'.

The aircraft had interesting, if not terribly colorful markings. As a very early -1A, she appears to have been delivered with the plain blue circle/white star insignias in effect in early 1943. In common with many other Corsairs in the SWPA, she had un-outlined white bars added. It would appear that at some point her left outer wing was replaced with one from an older aircraft that had wing insignias in four places rather than on only the upper left and lower right.

Her prop hub was entirely black, and the overall paint finish was very chalked, worn, and faded. These aircraft were 'rode hard and put up wet' as the saying goes, and their appearance reflected the hectic pace of operations during late 1943. Gun muzzle openings were usually taped, but the treatment varied with the day in question. Tape appeared over the seams on the outer wing panels as shown. There is no indication of tape around the fuselage tank forward of the cockpit however.





Left and below, 740 at Vella Lavella. The color photograph shows the landing light in the lower left wing (common to all early F4U-1As), as well as the chalked out appearance of the paint. Also note that there appears to be a different prop, this time with an Intermediate Blue dome.



Stills from a 16mm film of 740 taking off from Vella Lavella. Note the heavy paint chipping, fuel and oil stains, and generally scruffy appearance of the aircraft.





Detail Note

See the page on F4U antenna configurations for details on the antenna fit.

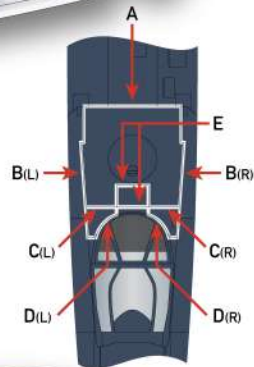

-  Non-Specular Sea Blue
-  Non-Specular Intermediate Blue
-  Non-Specular White

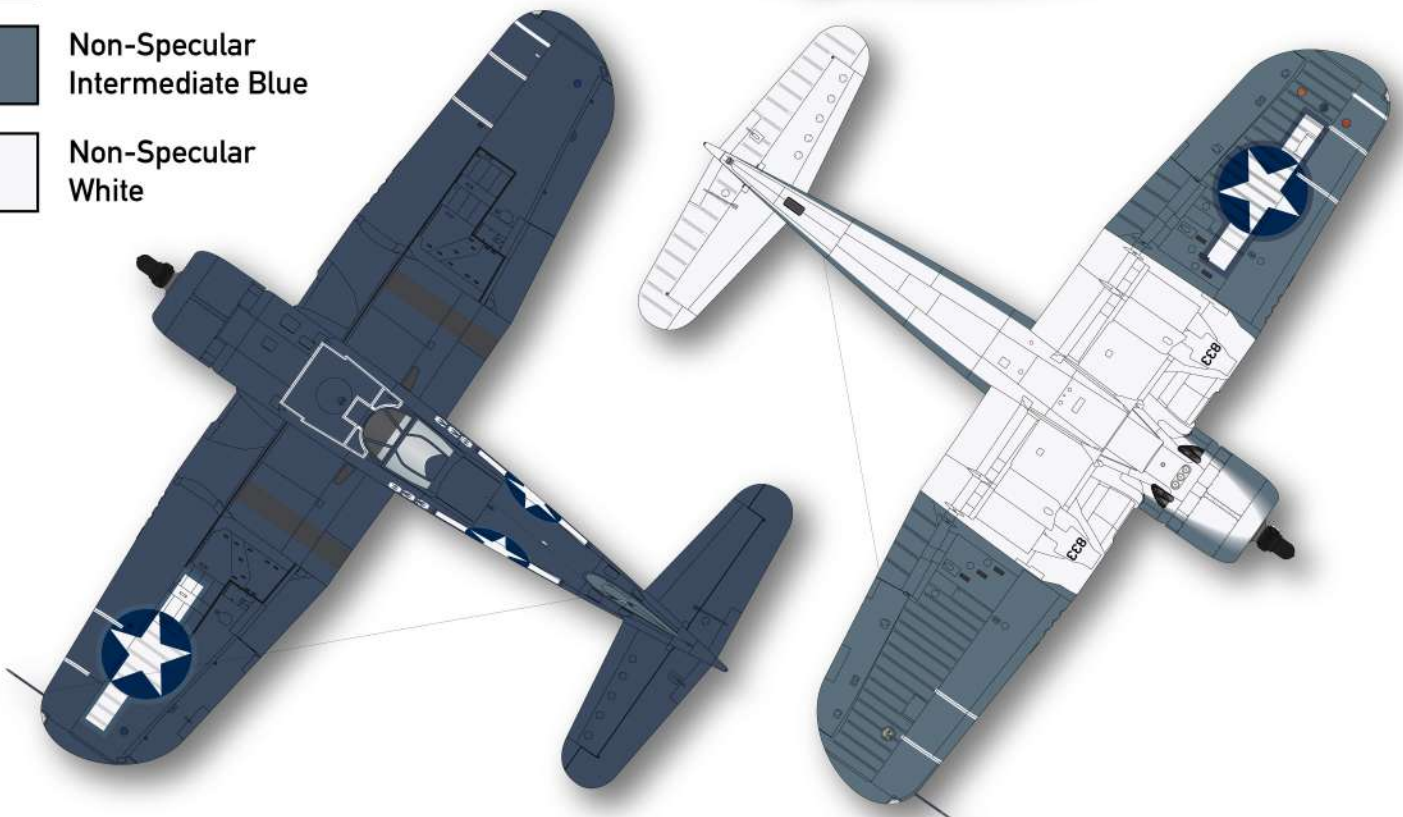



Quite a bit is known about Major Marion Eugene Carl. He's most often remembered for amassing 16.5 kills while flying F4F Wildcats at the Battle of Midway and on Guadalcanal. Following WWII he became a test pilot, setting several altitude and speed records. Later he flew top secret photo recce missions over Communist China in F2H Banshees, and he served in Vietnam.

What is not well known about Marion Carl is that his last two WWII victories were in Corsairs. Major Carl and VMF-223 returned to combat in November 1943, first at Vella Lavella before moving on to Torokina in December. On 23 December 1943 Major Carl flew F4U-1A #17833 (not to be confused with Boyington and Aldrich in their 17883) for his victory over a Ki-61 "Tony".



Three photos of Carl's 833 being manhandled into a parking spot at Vella Lavella in late 1943. Note the generally trashed appearance of the airplane's finish, with lots of fuel and oil spill stains, sealing tape on the upper fuselage and wing leading edges, and the borders on the national insignias. See following pages for information on the insignia colors.



Enlargement of pitot tube showing antenna mast.

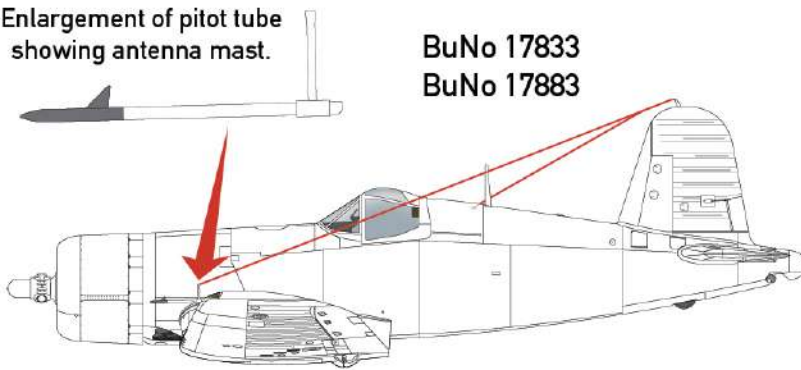

BuNo 17833
BuNo 17883

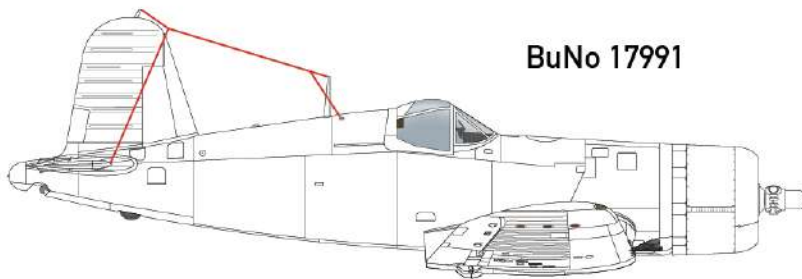
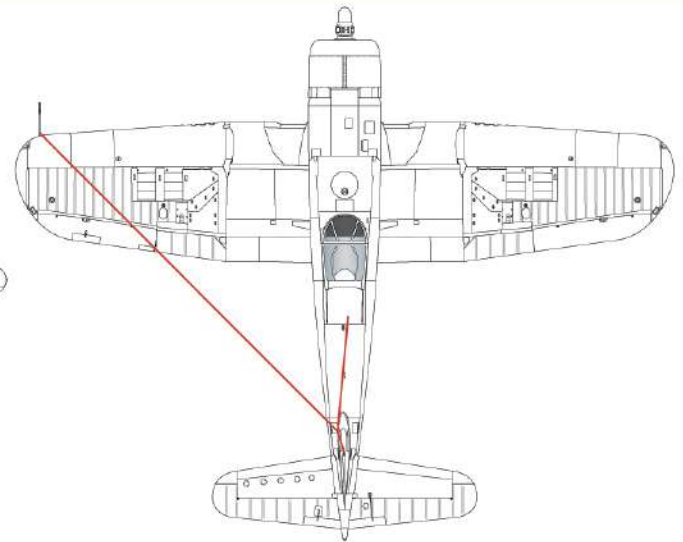

BuNo 17991

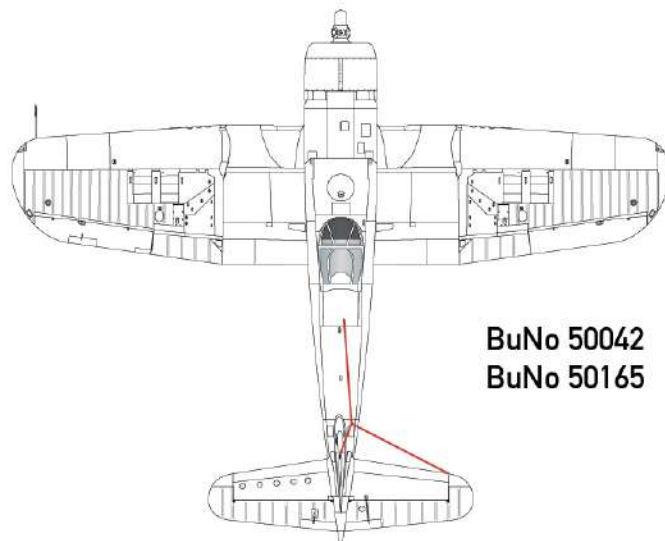

BuNo 50042
BuNo 50165

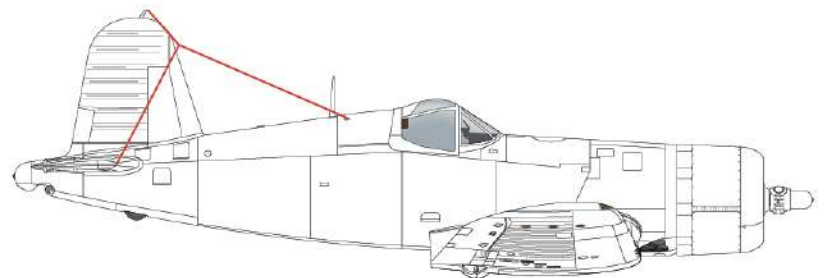

BuNo 17740
FF75
Buzz Bunny II
Grand Slam

With sincere thanks to Tommy Thomason of Tailhook Topics, we learned a great deal about Corsair radio antennas during the course of this project. Far from a cut and dried subject, there is still more work to be done here, but we believe these to be the correct antenna configurations for the aircraft shown. The one that really blew us away was that found on Marion Carl's 833 and on Boyington & Aldrich's 883. We had never seen such a setup before, but it's clearly there in photographs. There was a small post approximately 8" high, most likely attached with an encircling collar, at the end of the pitot tube just at the point where it attaches to the wing leading edge. Tommy has one photo of an airplane so equipped where the wing is folded and you can clearly see the slack antenna dangling from the small pitot tube mast. It's amazing that 70 years later we're still learning about this incredible airplane!

Oddly, and we can offer no explanation as to why, none of the three Fleet Air Arm aircraft we have depicted appears to have any long wire antennas whatsoever. And only one (Durno's) even appears to have a VHF set, as evidenced by the whip antenna aft of the cockpit. We have a large number of photos, as well as good quality film footage of these aircraft, and there's no sign of wires visible. If anyone has further information on this we would be most grateful if you would share it with us and our customers!

WHY WE DECIDED TO OPEN A BIG OLD CAN OF WORMS!



A lot of times, you can look at the same photographs a thousand times and see exactly what you saw the first 999 times. But occasionally something catches your attention, and you go back and look again. And every once in a while when you do that, you realize that the first 999 times you looked, you didn't really see what was there. We're the first to admit that making absolute pronouncements about colors based solely on black & white photographs is next to impossible. But we also adhere to the idea that when compelling new evidence leads us to an educated guess at odds with accepted conventional wisdom, we're willing to change our thinking!

There are films found in the National Archives of routine F4U operations in the Solomons in 1943 showing ground crews regularly touching up the camouflage paint on high traffic areas of these aircraft. What that tells us is that even in the far flung Solomon Islands, the supply chain had an adequate supply of Non-Specular Sea Blue, Intermediate Blue, and White. Careful study of numerous photos, including several color shots from this time period confirms this. But it would also seem to make sense, lacking any evidence to the contrary, that troops in the field would normally have had very little use for stocks of insignia colors. When the order came down to outline the new barred national insignias in the September of 1943 with blue, we figure that if a Marine was told to outline them in blue, he outlined them in whatever blue he had at hand. In this case, we think, based partly on the photos on this page, that Marines in the Solomons used a combination of the two blues they seem to have had in plenty: Intermediate Blue and Dark Sea Blue. Once you see it, you begin to see it with great regularity in photos from the Solomons in 1943 and 1944. Since the Dark Sea Blue was the closest thing they had to Insignia Blue, they seem to have used that, except where the camouflage was Dark Sea Blue, in which case Intermediate Blue was used. That means that the fuselage insignias on tri-color camouflaged F4Us got two colors, which neatly explains the photos showing them with a lighter color (Intermediate Blue) on the upper arc, and a darker color, but still not as dark as Insignia Blue, on the lower part and the bars. On the upper wings, Intermediate blue seems to have been used exclusively, while Dark Sea Blue was used on the lower wing insignias.

Historically, these lighter bordered insignias have been interpreted as being red. But based on the evidence we've seen, we believe that in most cases, Marine F4Us based in the Solomons in 1943 and 1944 had blue-bordered insignias as described here.

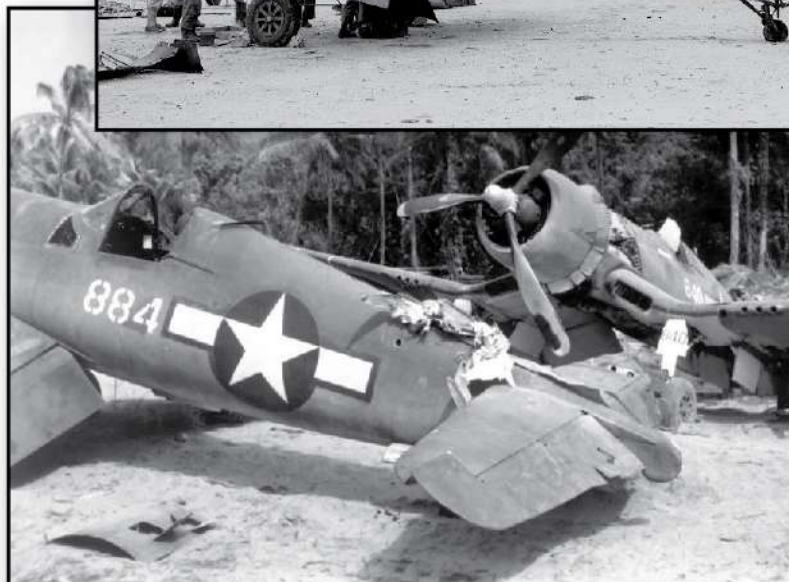



This photo shows the abysmal condition of Corsairs involved in hectic combat operations in the Solomons during late 1943 and early 1944. Between the sun, the salty air, and the effects of sand being blown by wind and props, the airplanes are downright trashed looking for the most part.



At left is an atmospheric shot of Vella Lavella airfield from December of 1943. Visible are Corsairs, Hellcats, a wingless SBD, and out near the beach a trio of RNZAF Kittyhawks. The tents house various maintenance shops, with a more permanent structure with hoists for prop and engine changes.



At right is a shot of the forward strip at Torokina, Bougainville. As can be seen, facilities were minimal to say the least.



Detail Note

See the page on F4U antenna configurations for details on the antenna fit.

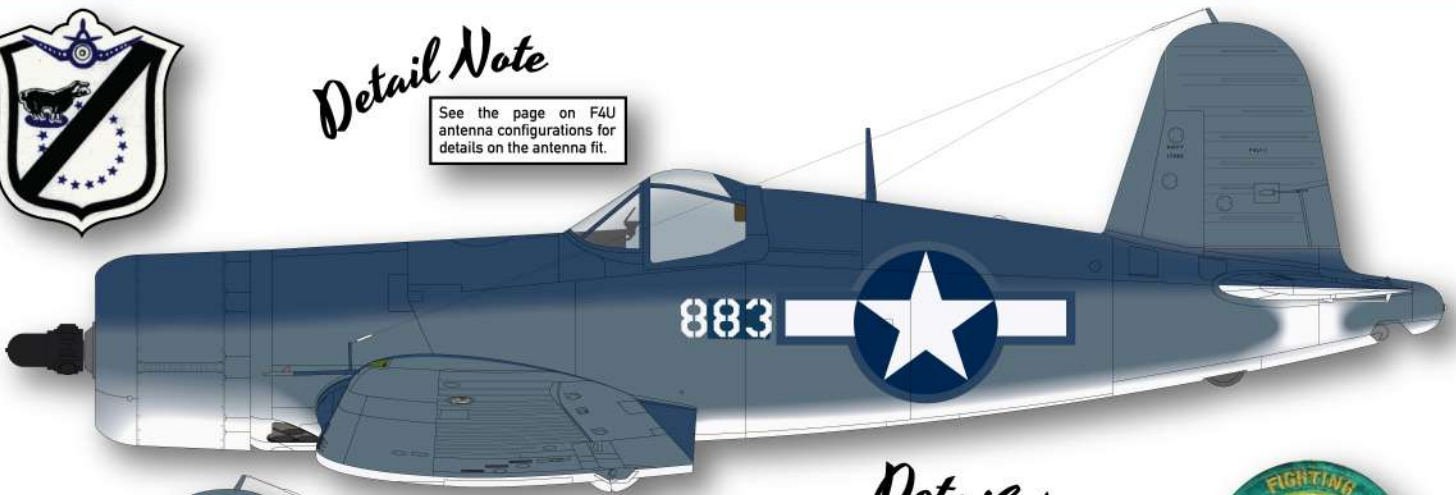

Detail Note

By the time Don Aldrich flew this aircraft, its rigid aerial mast had been replaced with a flexible whip antenna.

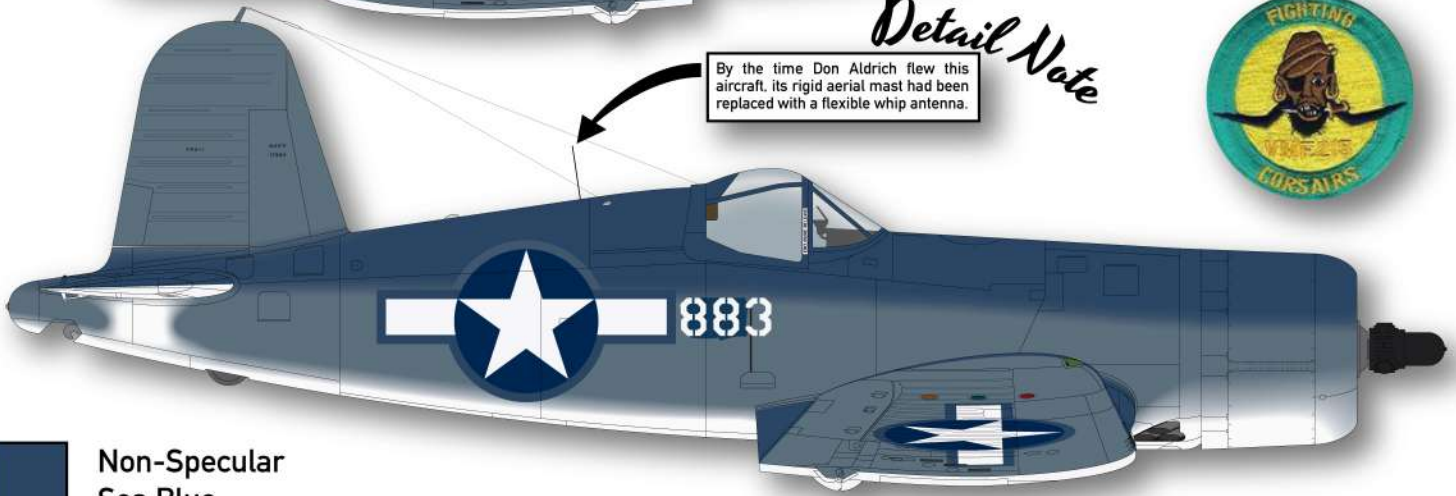

 Non-Specular
Sea Blue

 Non-Specular
Intermediate Blue

 Non-Specular
White

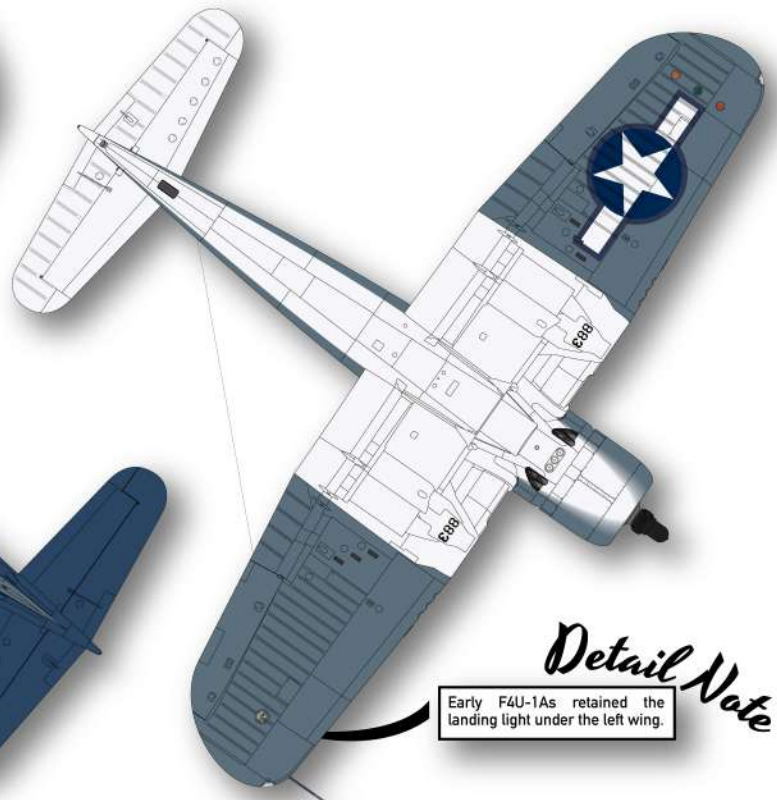
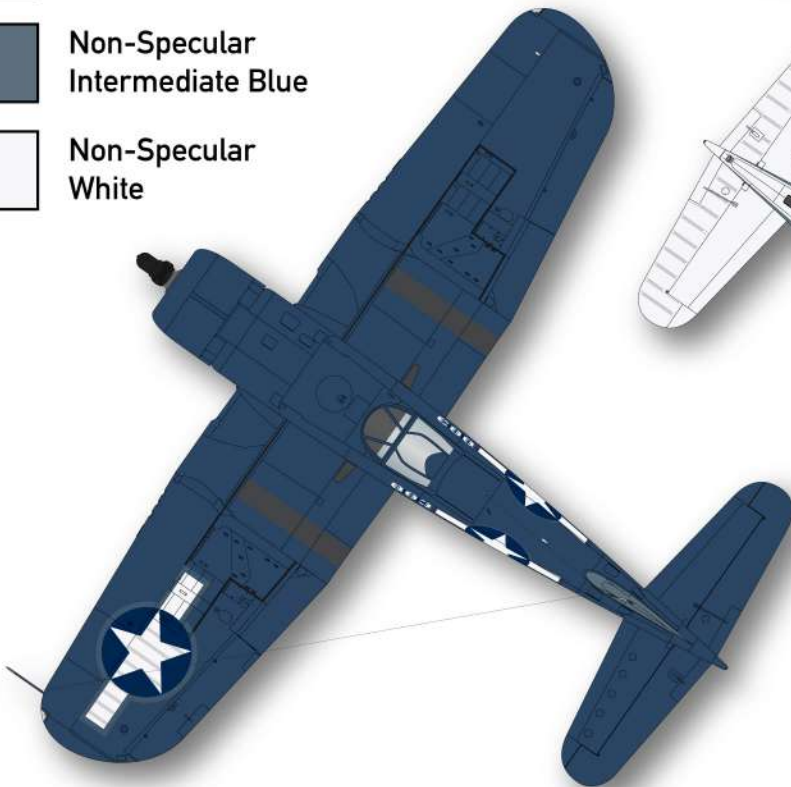

Detail Note

Early F4U-1As retained the landing light under the left wing.



Two photos of Boyington in the cockpit of 883. Note the earlier two-digit side number overpainted (we believe with fresh Dark Sea Blue), and the ragged edges of the numbers "883". It appears a stencil was used, but the paint applied with a brush or roller, resulting in bleed and paint drips. Also note the color of the border on the national insignias.



Maj. Gregory "Pappy" Boyington was in his element at the end of 1943. He was in command of a Marine Corps fighter squadron equipped with arguably the finest piston-engined fighter of its day and he was on pace to supplant Eddie Rickenbacker and Joe Foss as the highest scoring American ace. On 27 December 1943 Boyington was flying F4U-1A #17883 when he claimed what was likely his 21st aerial victory to that date (a Zeke). It is "likely" because of the discrepancy between what Boyington claimed with the AVG (6 kills) versus what he was given credit for (2 kills).

This series of photos was taken on 27 or 28 December 1943, when Boyington claimed a Ki-44 as a probable. One week later Boyington was shot down and made POW, having achieved a final victory tally of 24... or 28, depending upon which source you believe.

We would like to draw your attention to the antenna wire configuration on 17883. Notice the small vertical post protruding from the root end of the pitot tube, just visible in the photo at center left. This has not been well documented in illustrations and monographs (but is documented by Tommy Thomason on his blog). See the separate page on Corsair antennas for details. The unusual national insignia border colors are explained on page 8.

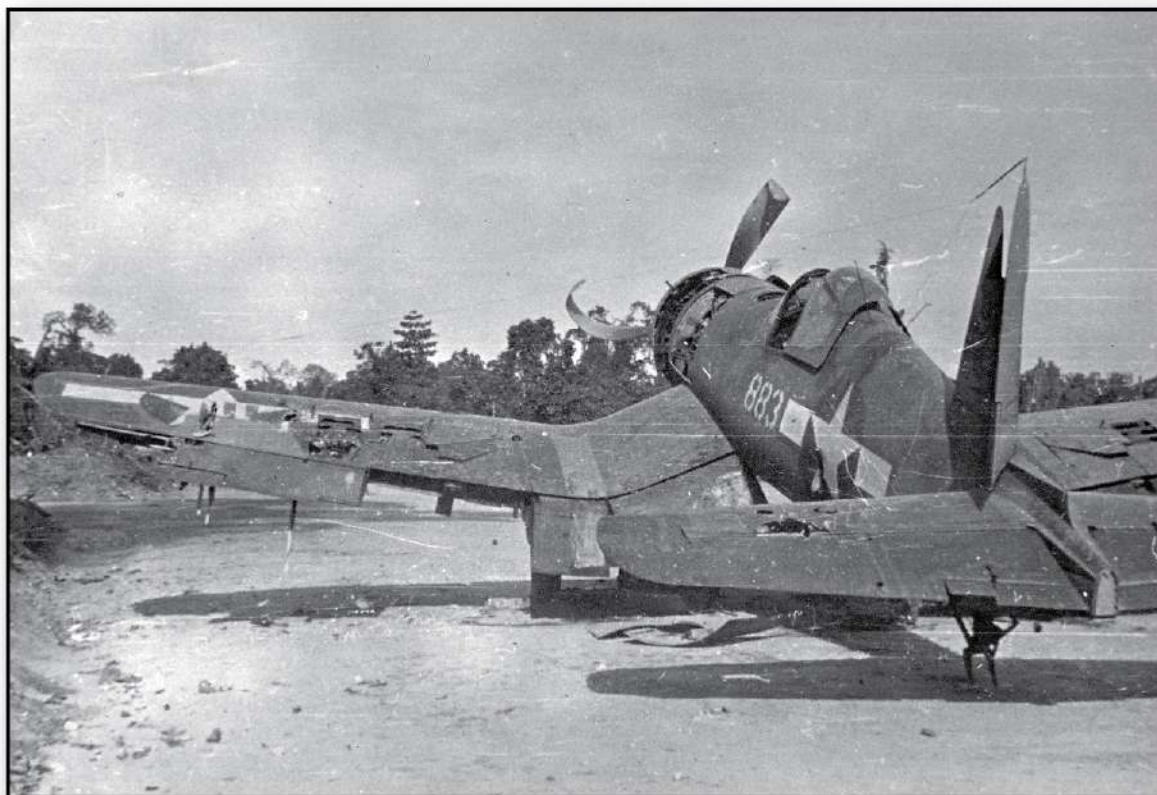

883 in the dump at Vella Lavella in January 1944. Despite the poor condition of the print, several interesting items are visible. First, note the wire antenna. It extends from the insulator lead-in on the right side behind the canopy, up to the rubber insulator attached to the tip of the rudder, then out to a small vertical mast affixed to the root end of the pitot tube (see antenna detail page). Another is the lighter colored border on the upper wing insignia. This has often been interpreted as red, but we disagree. See details on page XXXX.

Although Boyington's combat career was cut short on 4 January 1944, F4U-1A #17883 wasn't finished just yet. Captain Donald Nathan Aldrich of VMF-215 was at the controls of 883 when he shot down 4 Zekes on 28 January 1944. By now 883 had exchanged her hard radio mast for an offset whip aerial. On this day Aldrich was wounded in action and 883 was so badly damaged that she was written off. Aldrich survived the war with 20 confirmed aerial victories, but was killed in the crash of his F4U-4 in Chicago in 1947.





■ Non-Specular
Sea Blue

■ Non-Specular
Intermediate Blue

■ Non-Specular
White

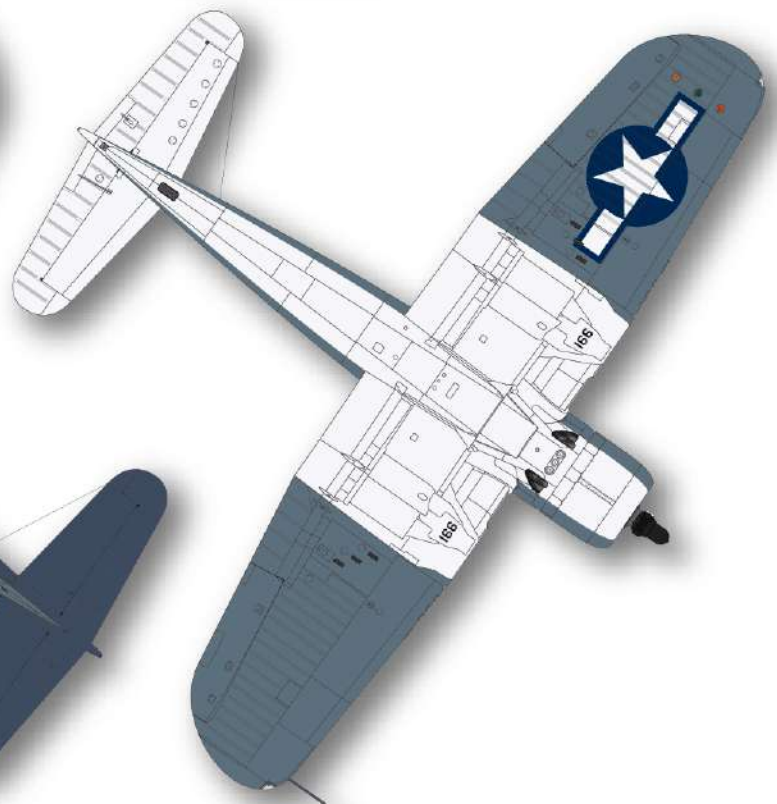
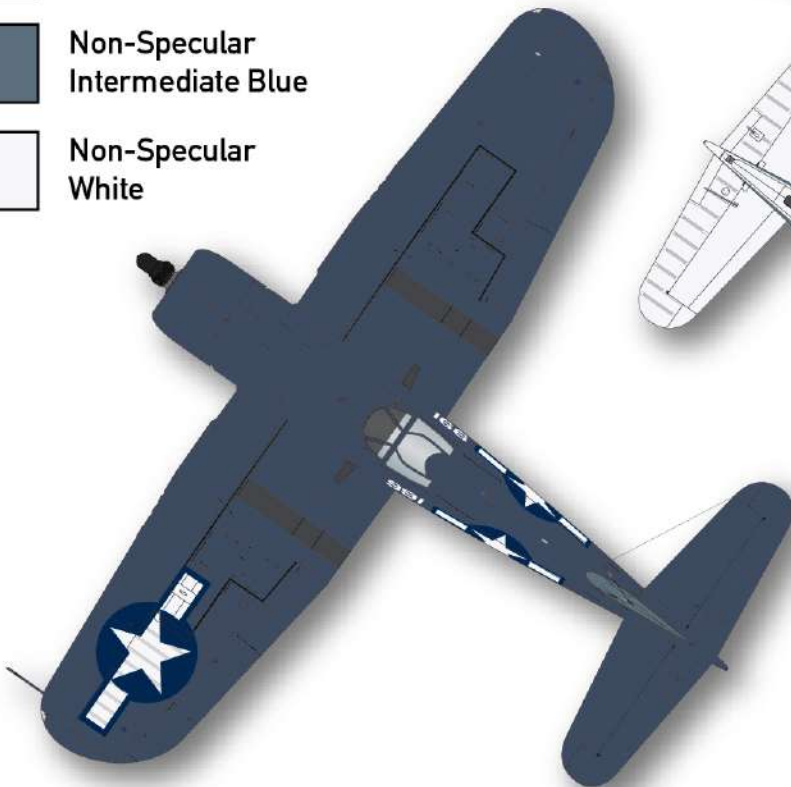



Major Marion Carl's last claims came while at the controls of F4U-1A BuNo 17991. On 27 December 1943 claimed a Zeke destroyed and another damaged during a fighter sweep over Rabaul. The aircraft was lost 16 February 1944 near Rabaul with Capt. Albert H. Pharr (VMF-216) at the controls.

Marion Carl retired from the military in 1973 having risen to Inspector General of the Marine Corps. In 1988 Marion Carl, one of America's greatest aviators, was shot to death during a home invasion.

Above: 991 undergoing nighttime maintenance in late 1943. Note the differing styles of '9' in the side code, as well as the paint drips.

Right and below: Carl posing with 991 on 5 January 1944. We have been unable to locate any other photographs of this aircraft.





Detail Note

The sealing tape on the forward fuselage could change from time to time, depending on where it was needed. This configuration represents one particular day.

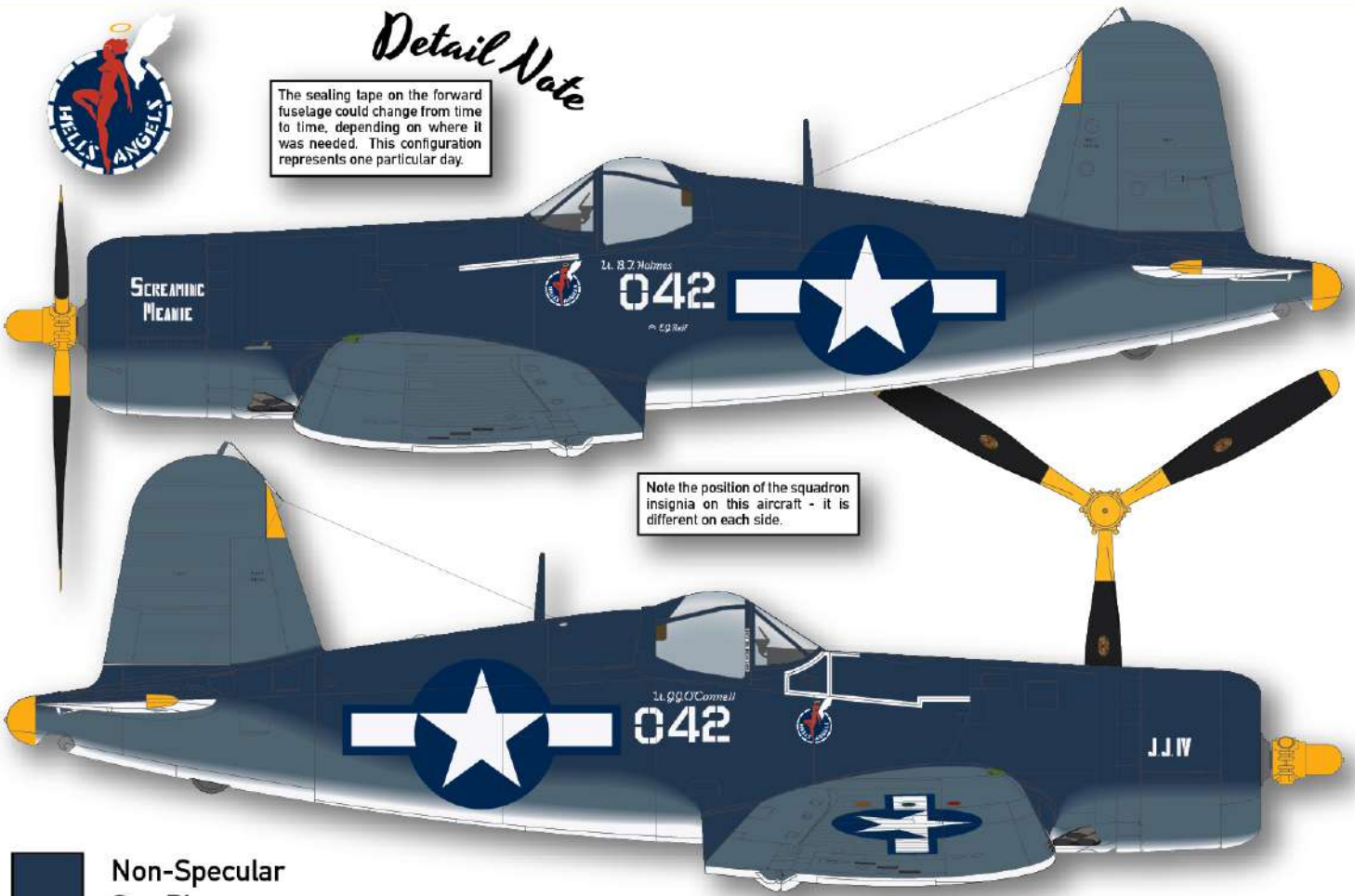

Note the position of the squadron insignia on this aircraft - it is different on each side.

- Non-Specular Sea Blue
- Non-Specular Intermediate Blue
- Non-Specular White

Detail Note

See the page on F4U antenna configurations for details on the antenna fit.

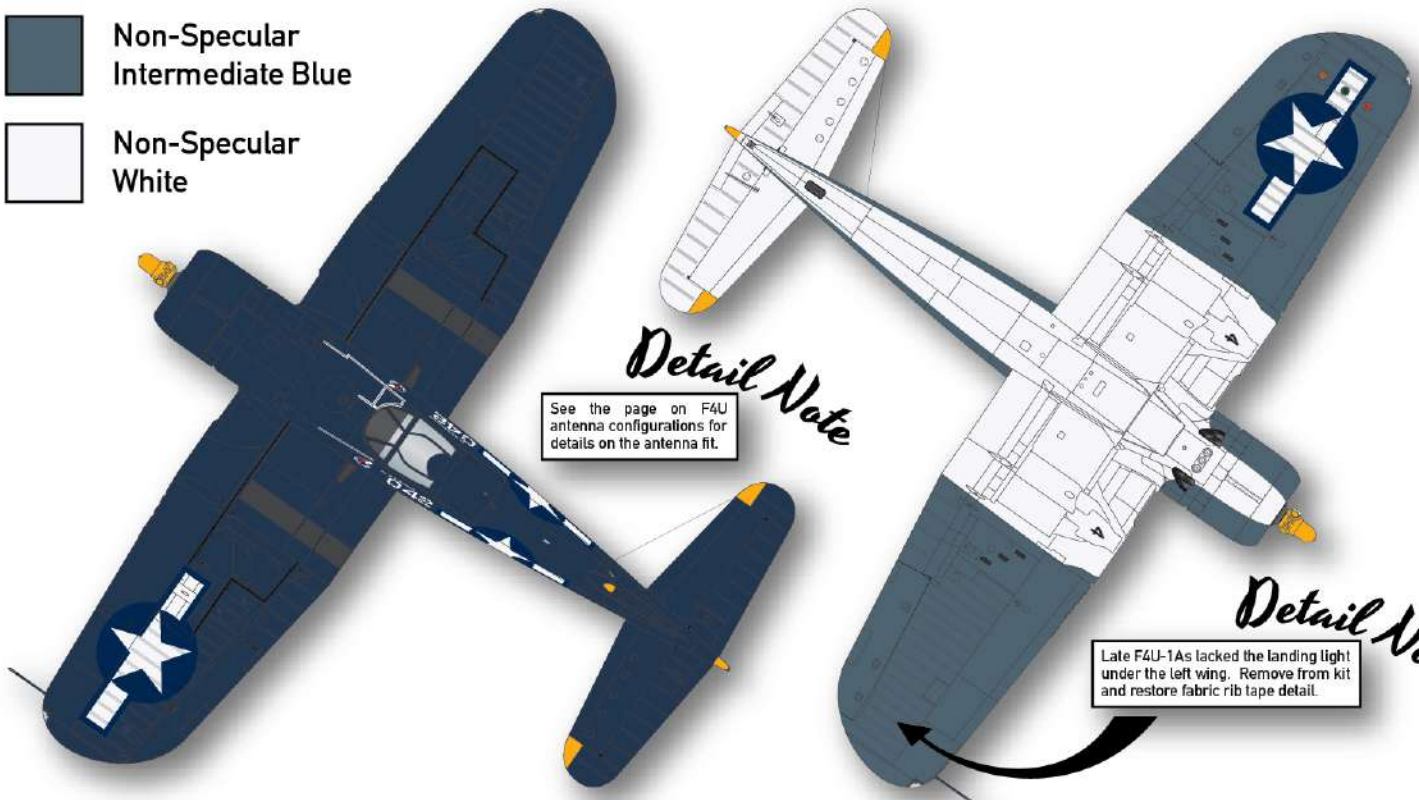

Detail Note

Late F4U-1As lacked the landing light under the left wing. Remove from kit and restore fabric rib tape detail.



Hank Weimer via Jim Sullivan

Two photos of 042 aboard the USS Kwajalein before arrival at Guam.

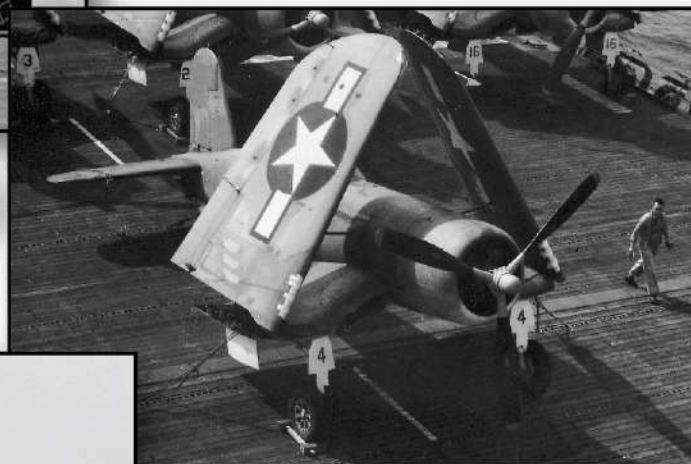

Hank Weimer via Jim Sullivan



Jim Sullivan

Left and above, taken on Guam. Note the color of the inner portion of the prop in the photo at left. The 1 1/2" wide tape used to seal the panels around the main fuel tank could change from time to time. We have depicted them as shown here, but you may find other configurations in photos taken at different times.



Jim Sullivan

In August 1944 VMF-321 shipped aboard the USS Kwajalein (CVE-98) and were ferried to Guam, from where for the next four and a half months they flew fighter-bomber sorties against Rota and Pagan. During this period the Corsairs of the "Hell's Angels" squadron wore yellow trim on the tail surfaces and the prop hubs. Planes were numbered on the gear door with '042' being number 4. There are different pilot's names on either sides of the cockpit: Lt. J.J. O'Connell on the starboard, while Lt. B.T. Holmes' name is painted on the port. O'Connell named his side of the plane "JJ IV" while Holmes decided upon "Screaming Meanie".

Many other depictions of these aircraft have shown the inner parts of the prop and the trim on the tail (where the latter is shown at all) as white. We firmly believe this trim was yellow, as borne out by these photos. Clearly it is darker than the other known white areas on the aircraft.



Detail Note

The sealing tape on the forward fuselage could change from time to time, depending on where it was needed. This configuration represents one particular day.



Detail Note

See the page on F4U antenna configurations for details on the antenna fit.



-  Non-Specular Sea Blue
-  Non-Specular Intermediate Blue
-  Non-Specular White

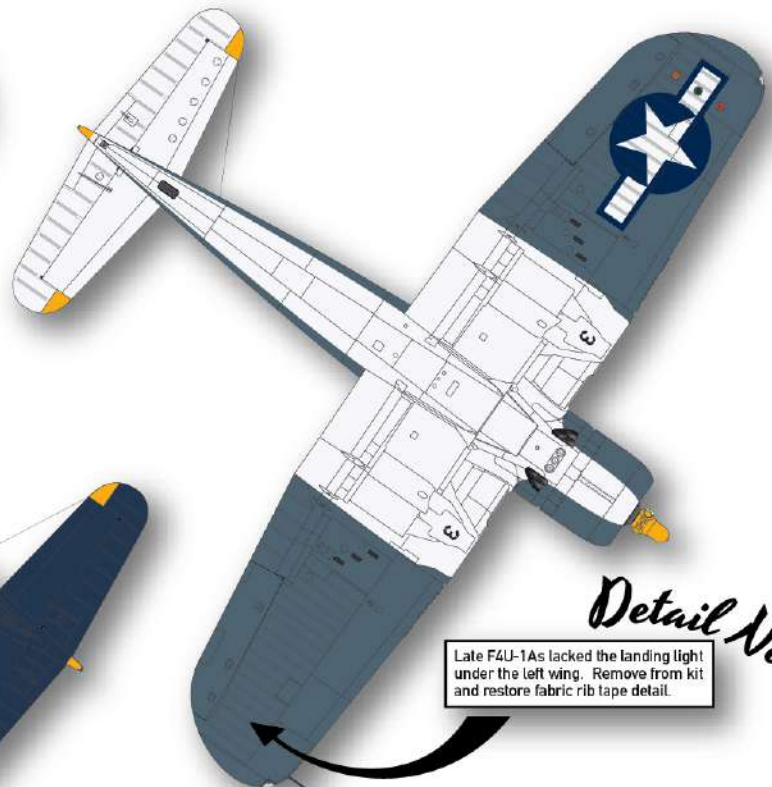
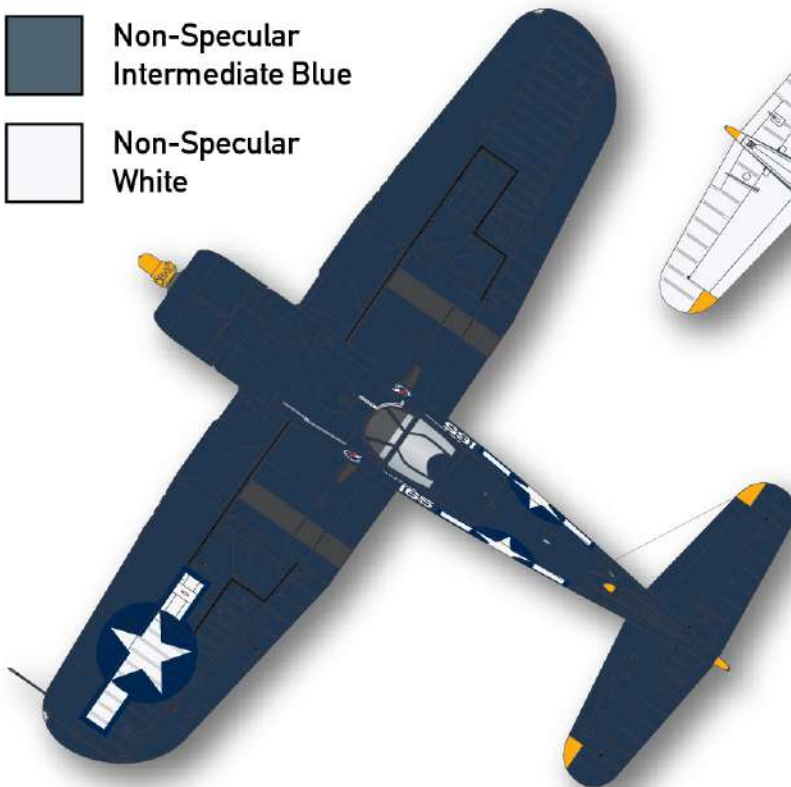

Detail Note

Late F4U-1As lacked the landing light under the left wing. Remove from kit and restore fabric rib tape detail.

F4U-1A 50165 was marked similarly to 50042, but carried the individual aircraft 3 on the forward gear door. There are different pilot's names on either sides of the cockpit; Capt. G.T. Doster on the starboard, while Lt. R.S.T. Marsh on the port. Doster's ship name was "Sweet Eloise", while Marsh's was "Peace Ever After".



Jim Sullivan



Hank Weimer via Jim Sullivan



Jim Sullivan



Jim Sullivan



Three photos showing the VMF-321 Hell's Angels emblem as applied to the squadron's F4U-1As. The CO of VMF-321, Maj. Edmund Overend, had been a member of the 3rd Pursuit Squadron of the AVG, the famed Hell's Angels. The squadron emblem painted on the AVG Curtiss Hawk 75s was invariably red. At left is a VMF-321 pilot's leather jacket from WWII showing a red angel (with very worn white wings). At right are photos of VMF-321 F4U-1As showing the squadron emblem. We firmly believe that the emblems painted on the Corsairs were red, and not a more realistic flesh tone as often depicted.



Maj. Ed Overend's "Winnie The Pooh, Too" on Guam. Unfortunately no photo showing the right side appears to exist, so we were unable to include it on our decal.



Lt. R. Whiting's "Luscious Lil-Nan" also on Guam. Every VMF-321 aircraft we have been able to find photos of both sides of has had a different name on each side. We have been unable to find a photo of the left side of Whiting's aircraft, so unfortunately we were unable to include it on our decal.

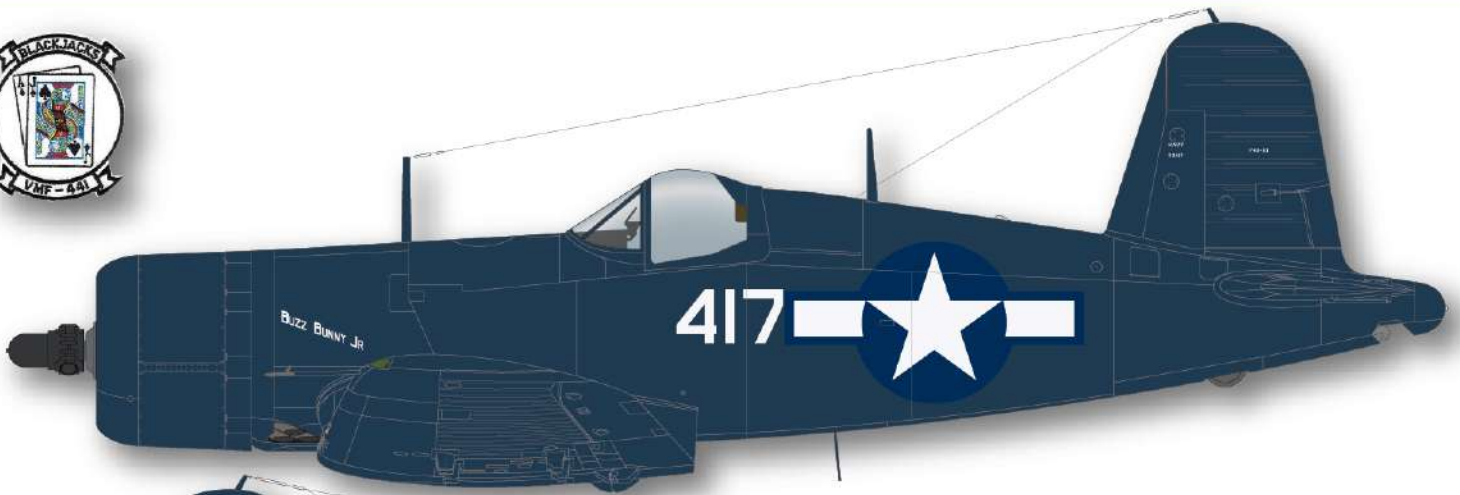

Navy Cross

Detail Note

Other than the standard national insignia, Eldridge's aircraft had no markings on its lower surfaces, including the forward main gear doors.

ANA 623
Gloss Sea Blue

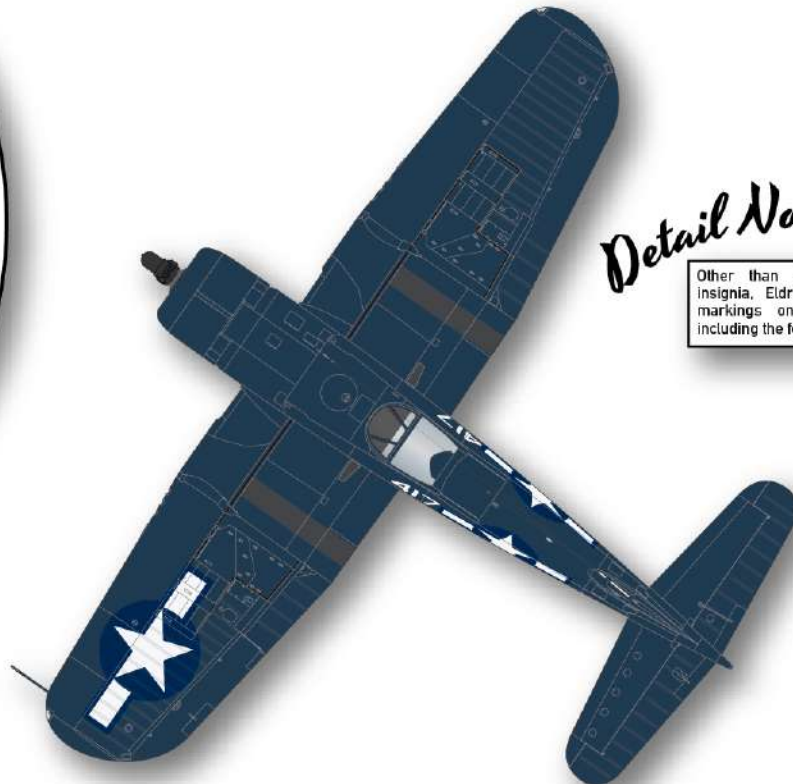



Eldridge and his aircraft, named "Buzz Bunny II".



On 15 April 1945 the destroyer USS Laffey (DD-724) had the unenviable task of acting as a radar picket ship north of Okinawa. That day the crew of the Laffey thwarted an enemy air attack resulting in 13 aircraft destroyed. The following day the Japanese sent 50 attackers to finish the Laffey. Corsairs of VMF-441 (among others) were vectored from Yontan airfield on Okinawa to the scene. During the mêlée that ensued, VMF-441 pilots splashed 16 of the attackers.

First Lieutenant William W. Eldridge, Jr. was top scorer, downing four Japanese aircraft: a Betty, 2 Vals, and a Zeke. But the Laffey still took direct hits from four bombs and six kamikazes leaving 32 dead and 71 wounded. For his actions that day, Eldridge was awarded the Navy Cross. When asked if the crew should abandon ship the Laffey's captain replied, "No! I'll never abandon ship as long as a gun will still fire." (To which a lookout mimicked softly, "And if I can find one man to fire it."). The Laffey was towed off the radar picket line for repairs on the 17th.

Tom W. Freeman's painting "Trial by Fire" depicting the 15 April 1945 Japanese attack on the USS Laffey (DD-724). Action on that day in defense of the Laffey earned Eldridge the Navy Cross.



ID stripes are 12" wide, or 6.35 mm in 1/48, 4.23 mm in 1/72.

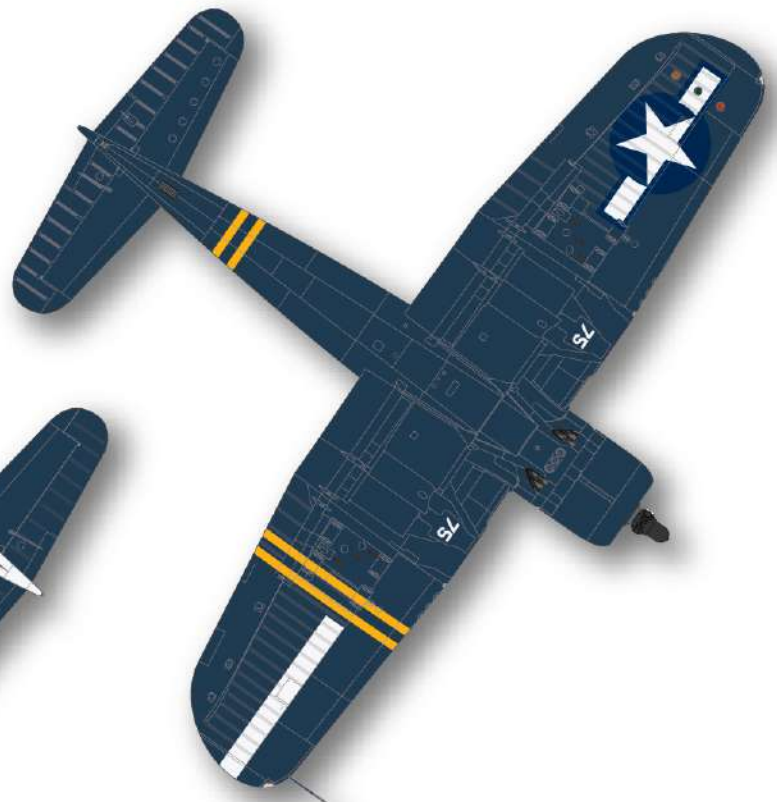
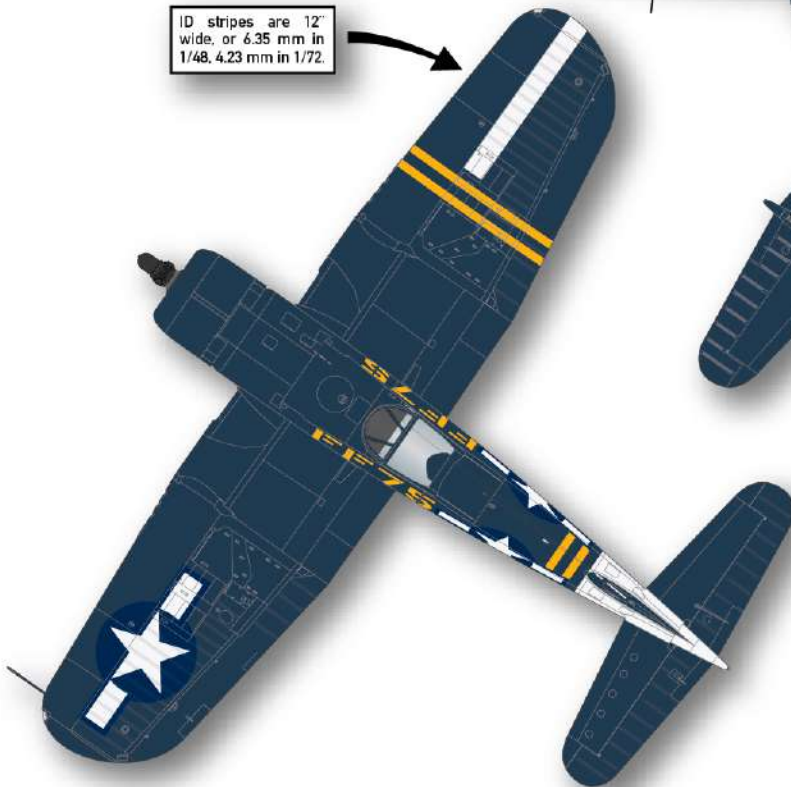

ANA 623
Gloss Sea Blue



Yost in the cockpit of FF75. His appears to have been the only aircraft in the squadron with a name applied.



Yost taxis FF75 forward after a trap. Note that between the west coast and Hawaii the squadron's side codes were painted white. Before they arrived in the combat zone they had been changed to yellow and the other identification markings applied.



The pilot of FF57 having a bad day, Yost's FF75 can be seen spotted forward with her wings folded. Note that by this time codes were yellow and full identification markings are applied. This photo was taken from near the port edge of the flight deck, giving a good indication of just how small a Jeep carrier really was.

Lieutenant Colonel Donald K. Yost was given command of MCVG-4 (Marine Carrier Group Four) in late 1944. The following year MCVG-4 embarked on the USS Cape Gloucester (CVE-109), and consisted of VMF-351 (Corsairs) and VMTB-132 (Avengers). Yost had previously become an ace with VMF-211 in 1942 flying Wildcats and added to his score in 1945. On 23 July Yost shot down a Judy. On 5 August he downed a Francis. It is likely that Yost was flying FF75 on both occasions (after all, it did have his name on it). Immediately following the end of the war MCVG-4 became part of the occupying force of Japan. On 11 September Yost flew FF75 off the Cape Gloucester en route to Omura airfield but clipped a telephone wire and crashed. Yost was not injured, but FF75 was a complete write off.

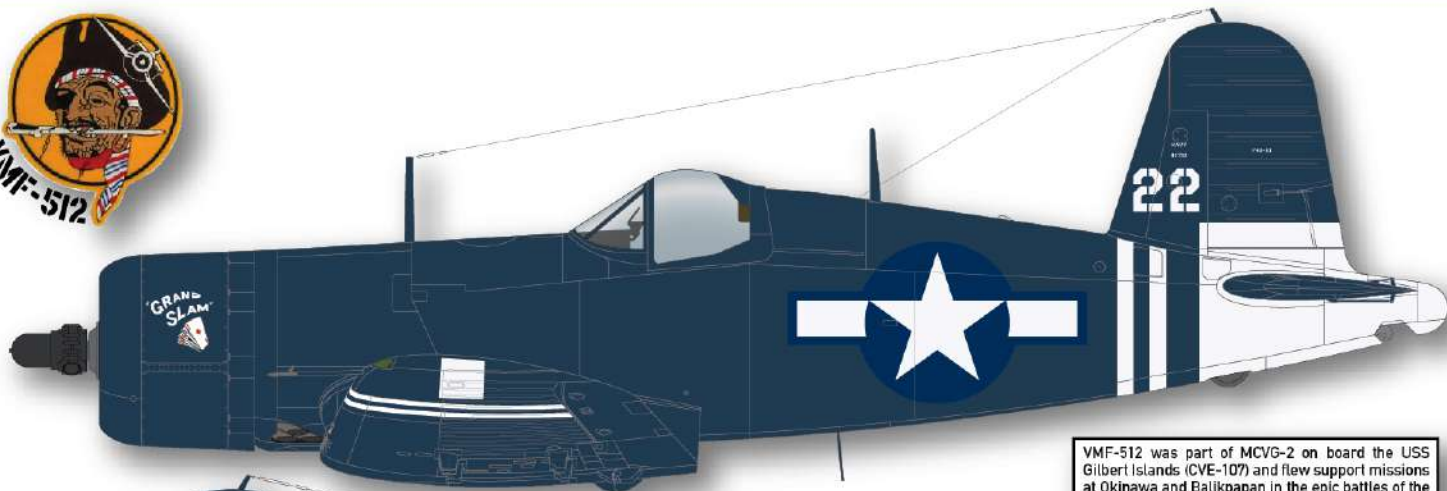

VMF-512 was part of MCVG-2 on board the USS Gilbert Islands (CVE-107) and flew support missions at Okinawa and Balikpapan in the epic battles of the summer of 1945.

For more photos and information on "Grand Slam" and VMF-512 please visit:

<http://www.adamsplanes.com/vmf-512.htm>

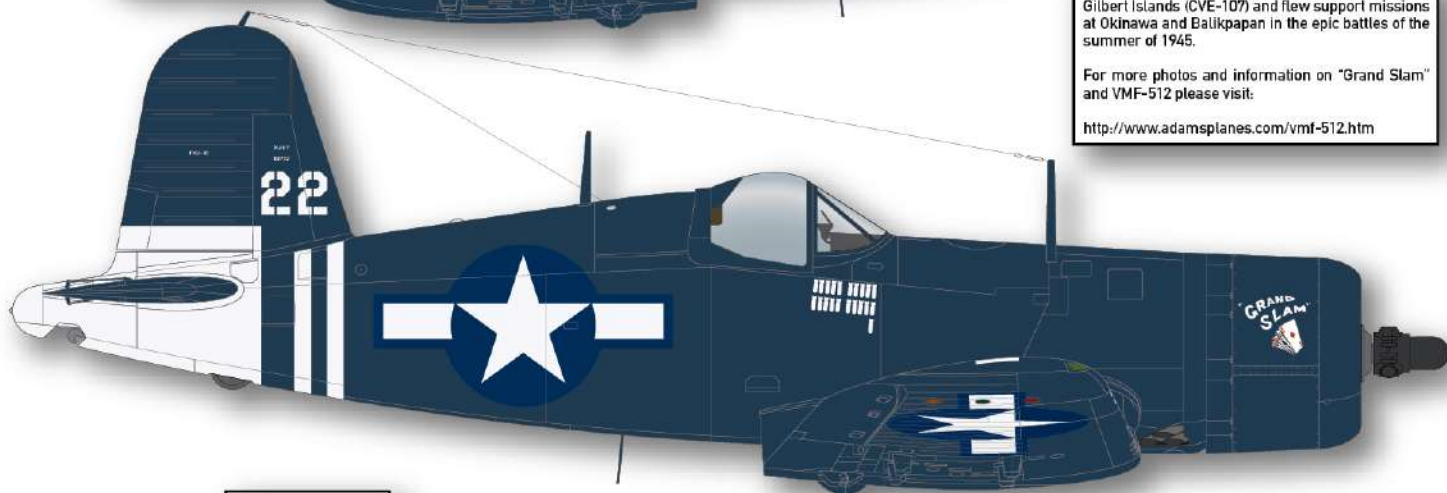

ID stripes are 12" wide, or 6.35 mm in 1/48, 4.23 mm in 1/72.



ANA 623
Gloss Sea Blue

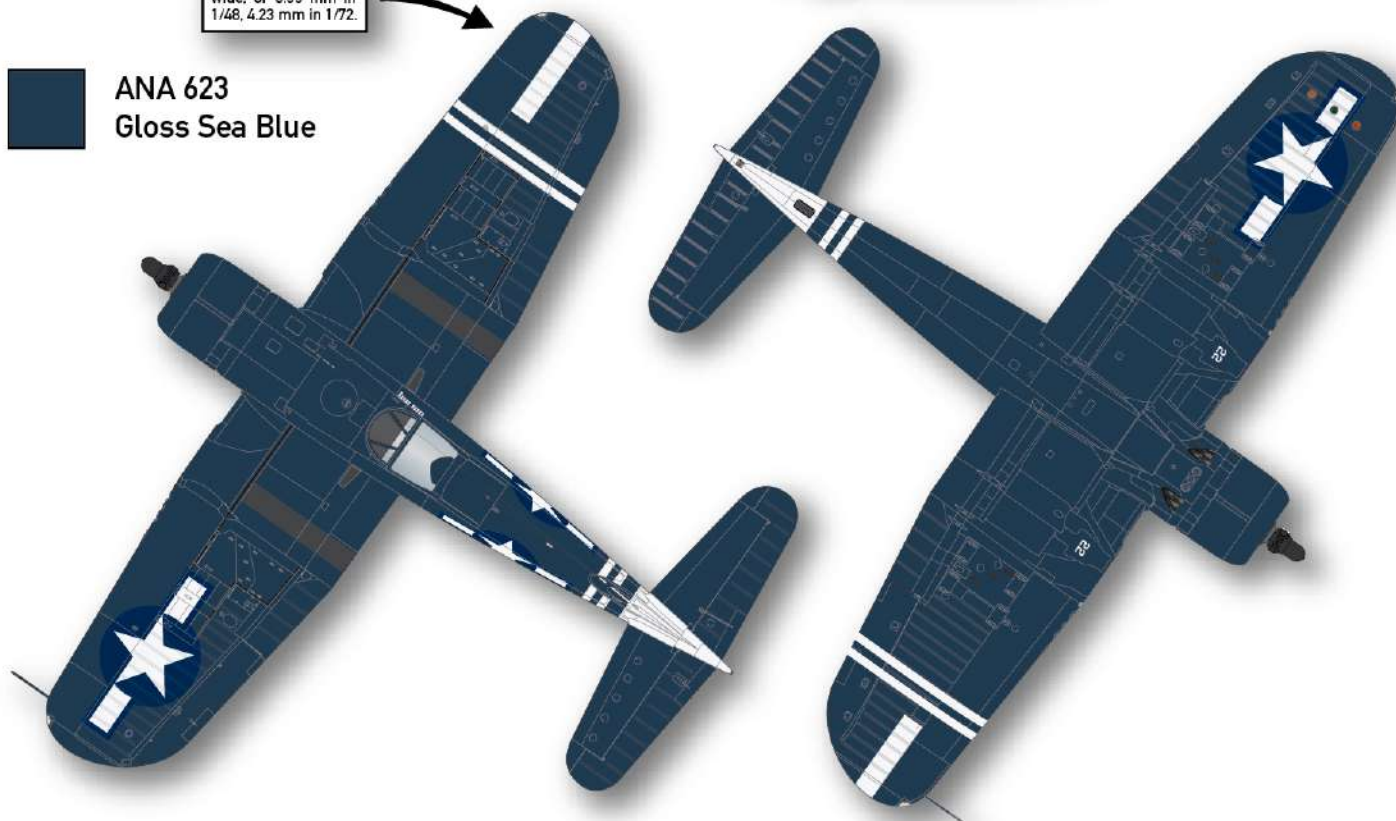

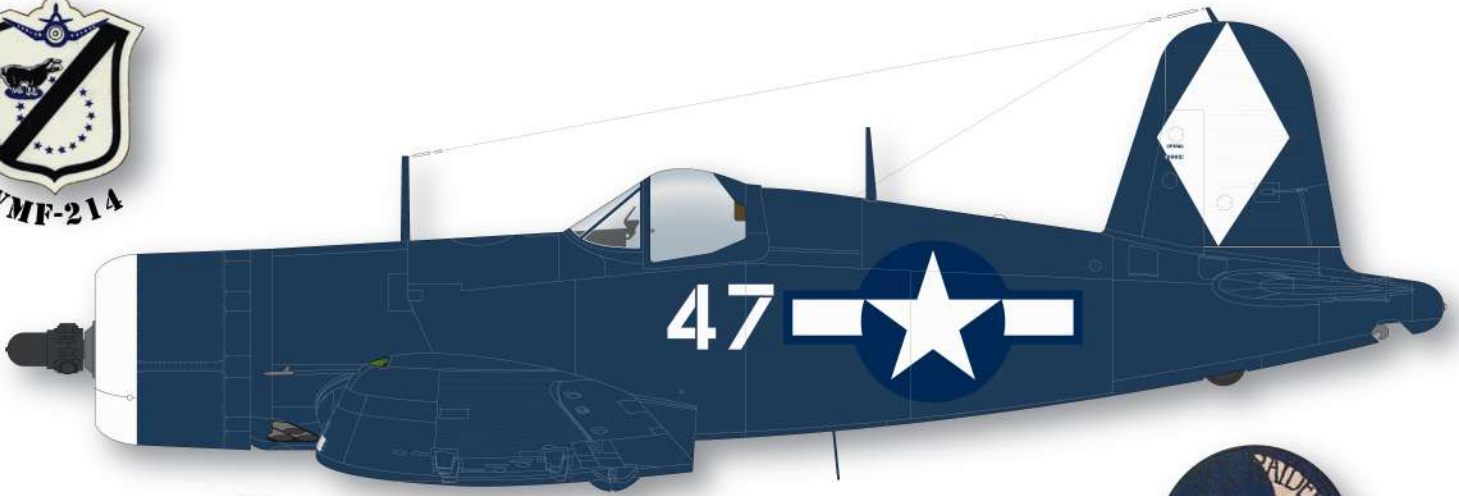

Note

Due to the limitations of the silkscreen printing process, we have provided extras of the small stencilled "NAVY", the Bureau Numbers. You may need to layer two of them to achieve a dense white against the Gloss Sea Blue.

Detail Note

All photos of Franklin air group F4Us show them carrying the Youngstown Steel Door Co. Mk.5 universal tank.

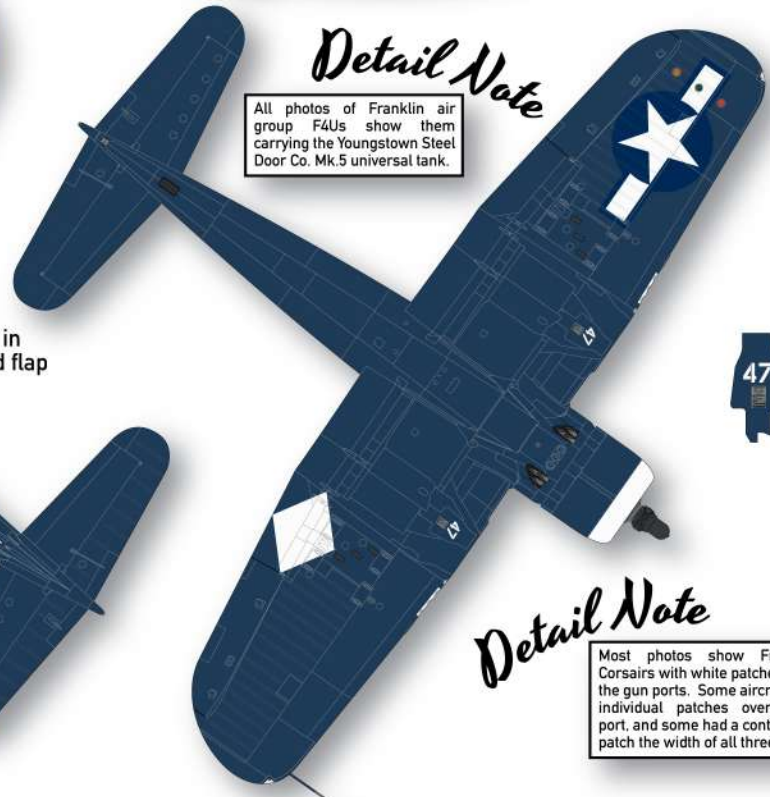
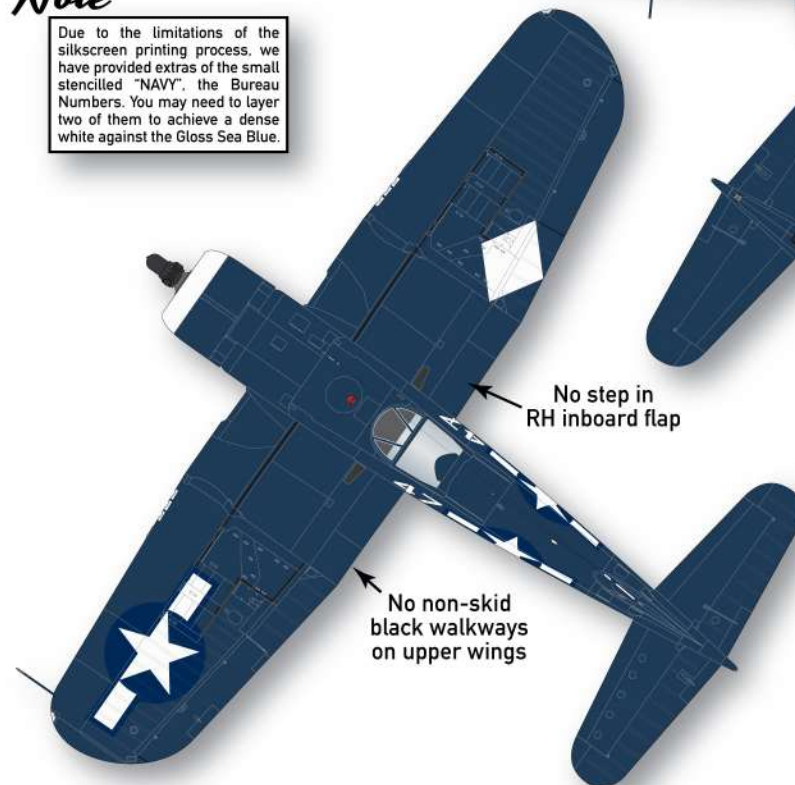

Detail Note

Most photos show Franklin Corsairs with white patches over the gun ports. Some aircraft had individual patches over each port, and some had a continuous patch the width of all three.

ANA 623
Gloss Sea Blue



Some CVG-5 History...

VMF-452 was commissioned at Marine Corps Air Station Mojave, California. On February 7, 1945, the squadron departed San Francisco on board the aircraft carrier USS Franklin (CV-13). From there they sailed to Pearl Harbor and then moved west to join up with Task Force 58 which was heading to support the invasion of Okinawa. On March 18 they flew their first combat missions against airfields on Kyūshū Island. The following day, the Franklin was attacked by a Japanese Yokosuka D4Y Judy dive bomber. Both of its two 500-pound bombs stuck the Franklin. 33 members of VMF-452 were killed in the ensuing devastation and the squadron was no longer combat effective. They transferred to the USS Bunker Hill and set sail for the United States.

VMF-214 was re-formed on 29 January 1944 at MCAS Santa Barbara near Goleta, California. After more than a year of training they deployed aboard USS Franklin on 4 February 1945 to join on-going operations on Okinawa. On 19 March, a Japanese bomber hit USS Franklin. The explosion and resulting fire caused 772 deaths aboard Franklin including 32 Black Sheep members. Many aircraft were launching for a strike on mainland Japan at the time. One, 1 Lt Ken Linder, was given half credit for shooting down the Japanese bomber that struck Franklin. This ended VMF-214's involvement in World War II. During the course of the war, the squadron suffered 23 pilots killed in action or missing and lost 48 aircraft to accidents or enemy contact.



Left: A still from a short film clip of F4U-1D #47 doing a low fly-by of Franklin in early March 1945. Note the white forward cowling and the Youngstown Steel Door Mk.5 universal drop tank.

Below: F4U-1D #55 trapping aboard Franklin. Note the orientation of the diamond on the wing, and that it only covers the portion of the flap visible when retracted. Most previous illustrations have not shown the diamond in the correct location or shape as depicted in these photos.



An explosion rocks the USS Franklin on the morning of 19 March 1945. Her first wave was airborne and the second wave was being armed and fueled (many on the hangar deck aft), including the 11.75" Tiny Tim rocket. Frequently misquoted as being a kamikaze attack, it was in fact a level bombing attack by a D4Y Judy, which put two 250 kg bombs through Franklin's flight deck before escaping into the low cloud. The Judy had come in below radar coverage, and some crewmen aboard Franklin thought at first it was a TBM dropping a weighted message bag, as it came in straight down the deck from bow to stern. One of the bombs penetrated the flight deck, setting massive fires on the hangar deck among the fueled and armed aircraft. Most of Franklin's damage was due to fuel fires and explosions and "launches" of the Tiny Tim rockets, which were then removed from combat for the rest of the war.

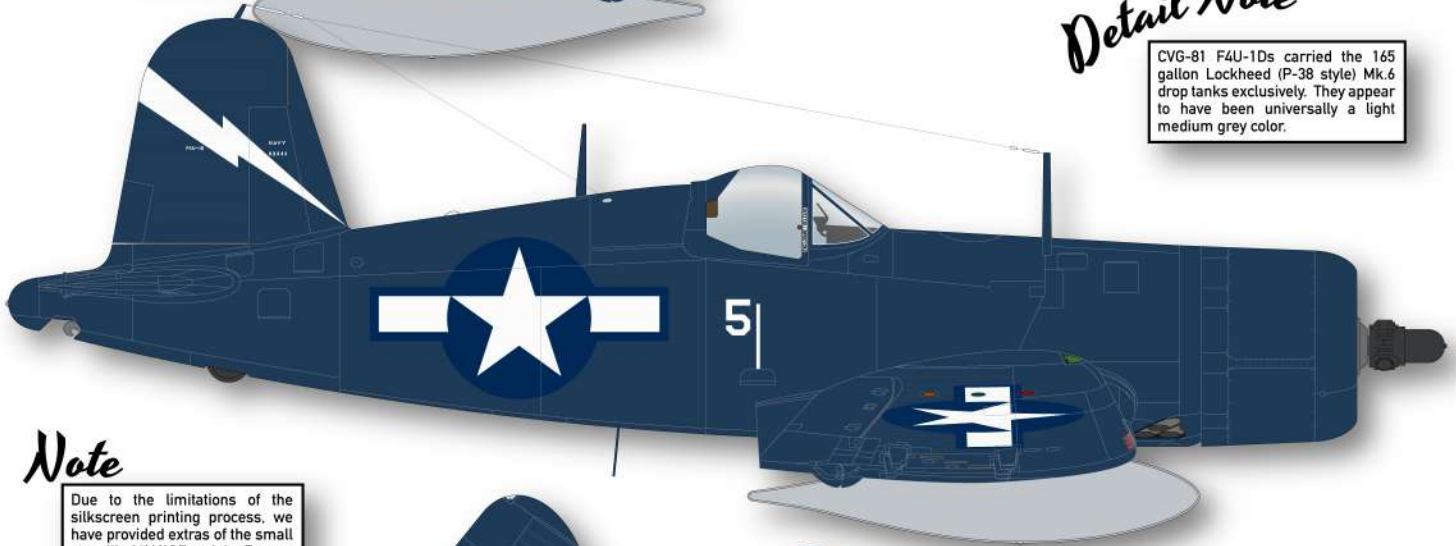
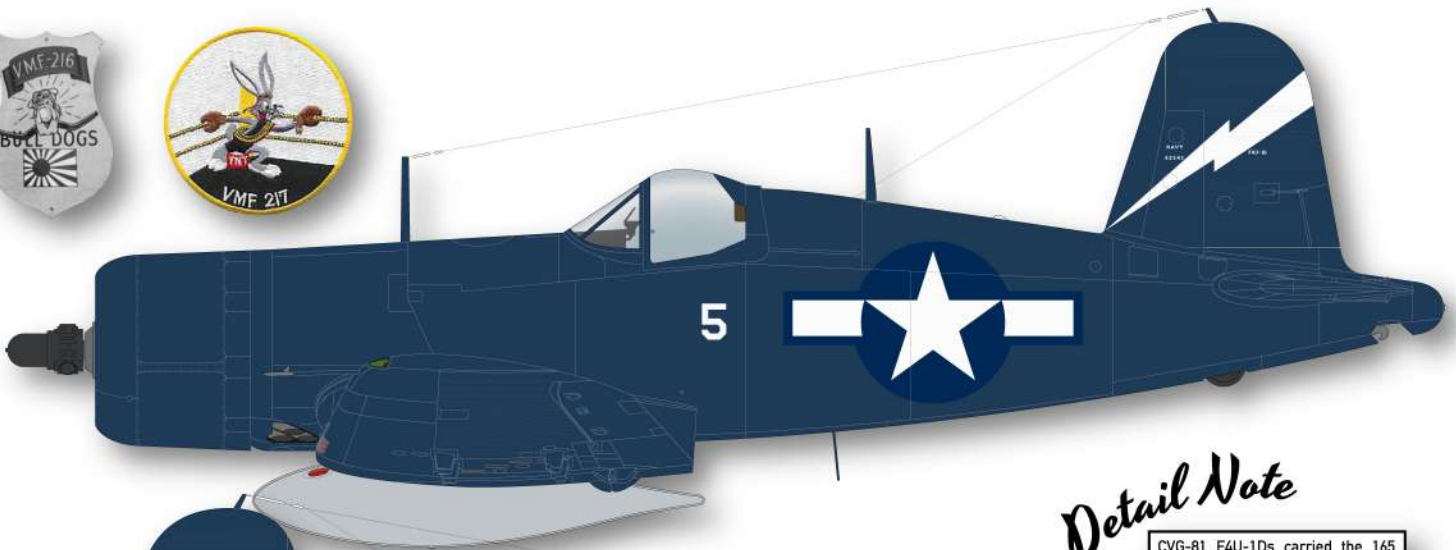

Detail Note

CVG-81 F4U-1Ds carried the 165 gallon Lockheed (P-38 style) Mk.6 drop tanks exclusively. They appear to have been universally a light medium grey color.

Note

Due to the limitations of the silkscreen printing process, we have provided extras of the small stencilled "NAVY" and the Bureau Number. You may need to layer two of them to achieve a dense white against the Gloss Sea Blue.

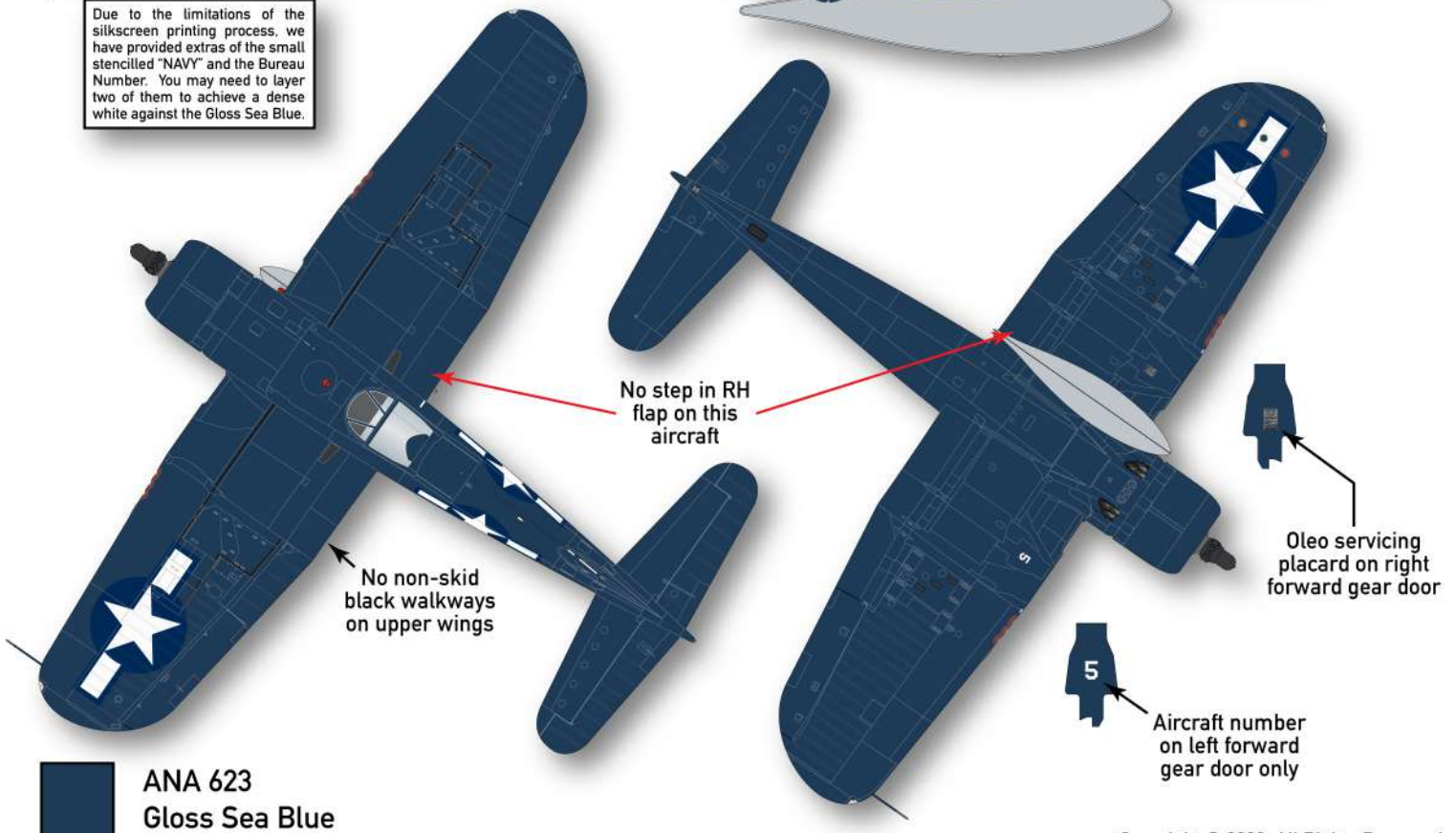

ANA 623
Gloss Sea Blue



Some CVG-81 History...

Operations aboard the USS Wasp in early 1945 were conducted by Carrier Air Group 81, which consisted partially of two Marine F4U-1D squadrons, VMF-216 and VMF-217. The two squadrons operated a pool of aircraft that were identically marked, with no distinguishing squadron markings. Photos of CVG-81 aircraft from this time period are rare due to the Wasp's short time on the line prior to being put out of action on 19 March, but these photos show the very short-lived lightning bolt markings used in early 1945.

VMF-216 and -217 were commissioned in 1942 and early 1943 at MCAS El Centro, California. They first experienced combat when based on Bougainville in January 1944, with strikes against the Japanese garrison at Rabaul.

The squadrons ended up on Guam in late 1944, and eventually re-equipped with F4U-1Ds, joining CVG-81 aboard USS Wasp in early February 1945. Both squadrons took part in the raids on the Japanese home islands - and Tokyo in particular in February 1945, the first strike on Tokyo since the Doolittle Raid in April of 1942.

Both squadrons participated in the Battle of Iwo Jima and the other operations of TF.58 in early 1945. On 19 March 1945 the Wasp was severely damaged by a bomb, and VMF-217 returned to the US before reorganizing as an F6F squadron, thus freeing up F4Us for anti-kamikaze duties. VMF-216 was decommissioned after USS Wasp returned to the US for repairs.



Photos: USN

Although these stills from a 16mm motion picture aren't of the best quality, we believe they are historically very important. To our knowledge, these very short-lived markings have never been documented anywhere before. Prior to the 27 January 1945 directive implementing the so-called "G-symbol" system of carrier air group markings, each CVG had devised its own design. From 1943 to early 1945, USS Wasp had used a small equilateral triangle (pointed up) at the top of the vertical fin. For reasons unknown, when VMF-216 and -217 (and VBF-86) brought their Corsairs aboard the Wasp on 4 February 1945, they chose a slim lightning bolt as their ID marking. Since the directive on the G-symbols was already in channels and was implemented aboard the Wasp before the Corsairs' first combat missions, these markings can only have existed for a few days at most. More commonly associated with the lightning bolt is the air group aboard USS Shangri-la, but that version was much heavier with more 'zig zags' than the simpler, slimmer Wasp version. We do not believe these markings were carried when Wasp's F4Us started combat operations in March of 1945.