

Note: Decals A26 and A27 may be positioned at the top or the bottom of the round access panels, depending on whether the taller "NAVY" or shorter "MARINES" titles were applied. Most F-4Bs, even those that were delivered directly to USMC units, left the factory with "NAVY" applied, with these items positioned as shown.

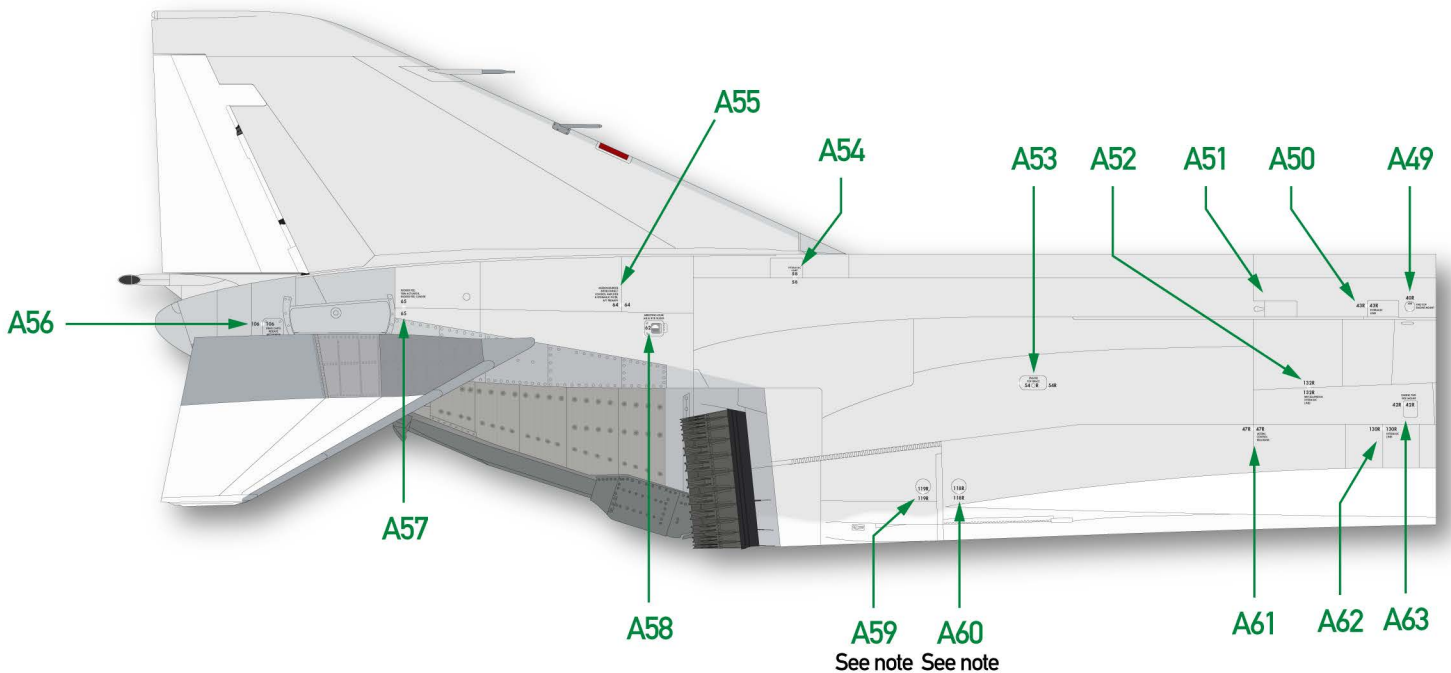

Note: Decals A59 and A60 may be positioned at the top or the bottom of the round access panels, depending on whether the taller "NAVY" or shorter "MARINES" titles were applied. Most F-4Bs, even those that were delivered directly to USMC units, left the factory with "NAVY" applied, with these items positioned as shown.

### Early production blocks

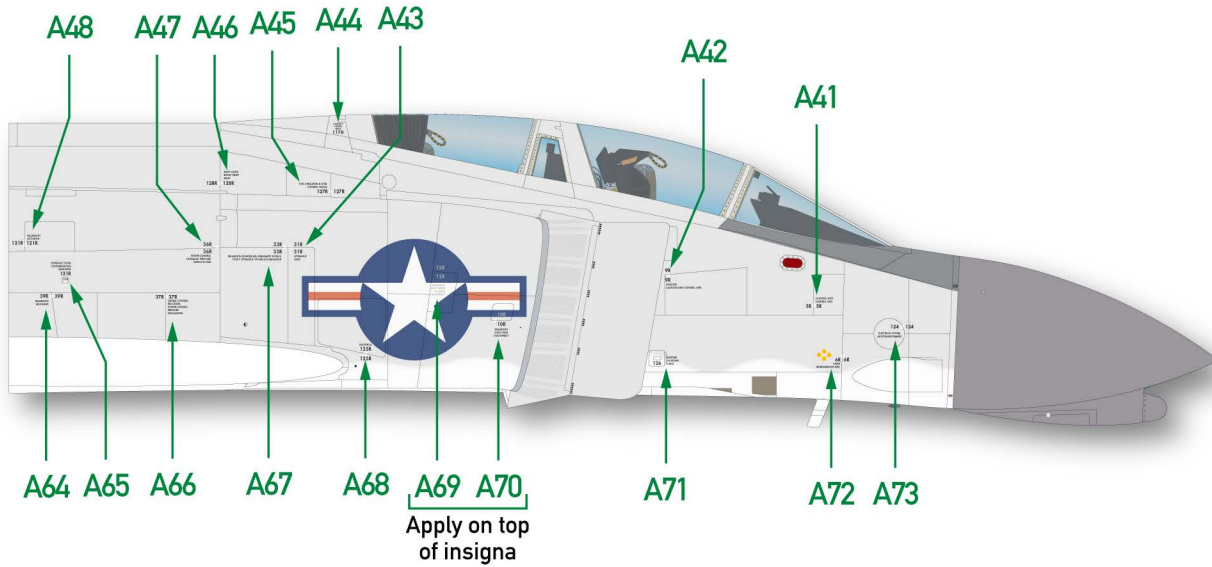
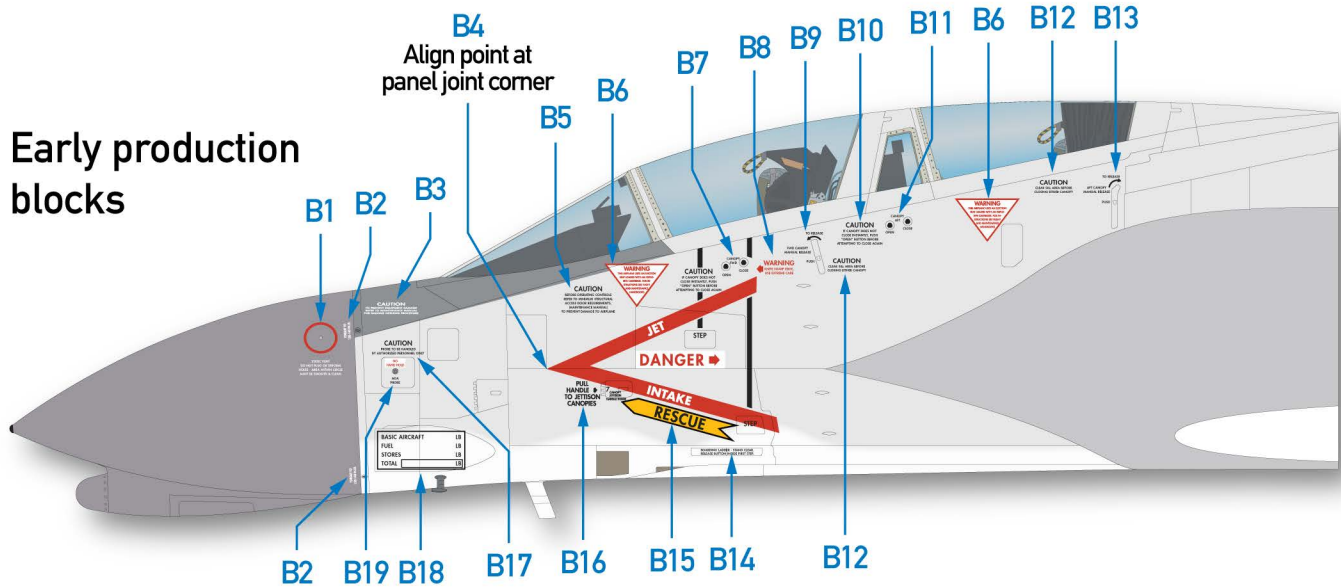

### Late production blocks

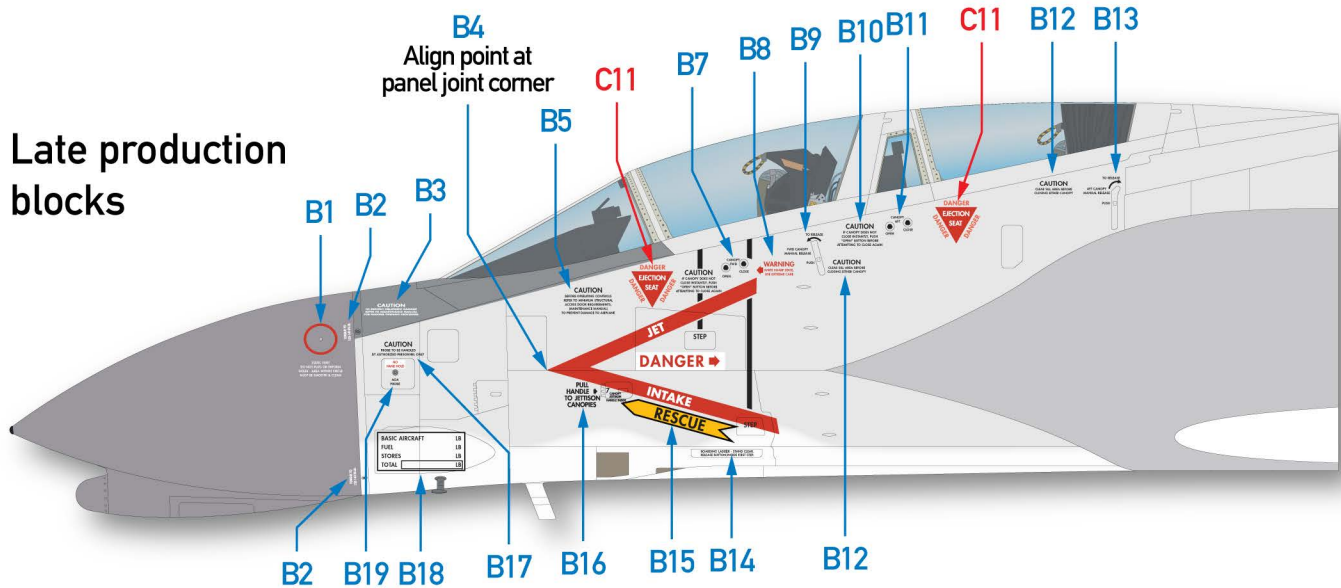

#### Notes:

C11: The white-on-red (USAF style) ejection warning triangle was introduced in January 1966 from Block 25 onwards (BuNo 152965). Older aircraft retained the earlier style until depot overhaul.

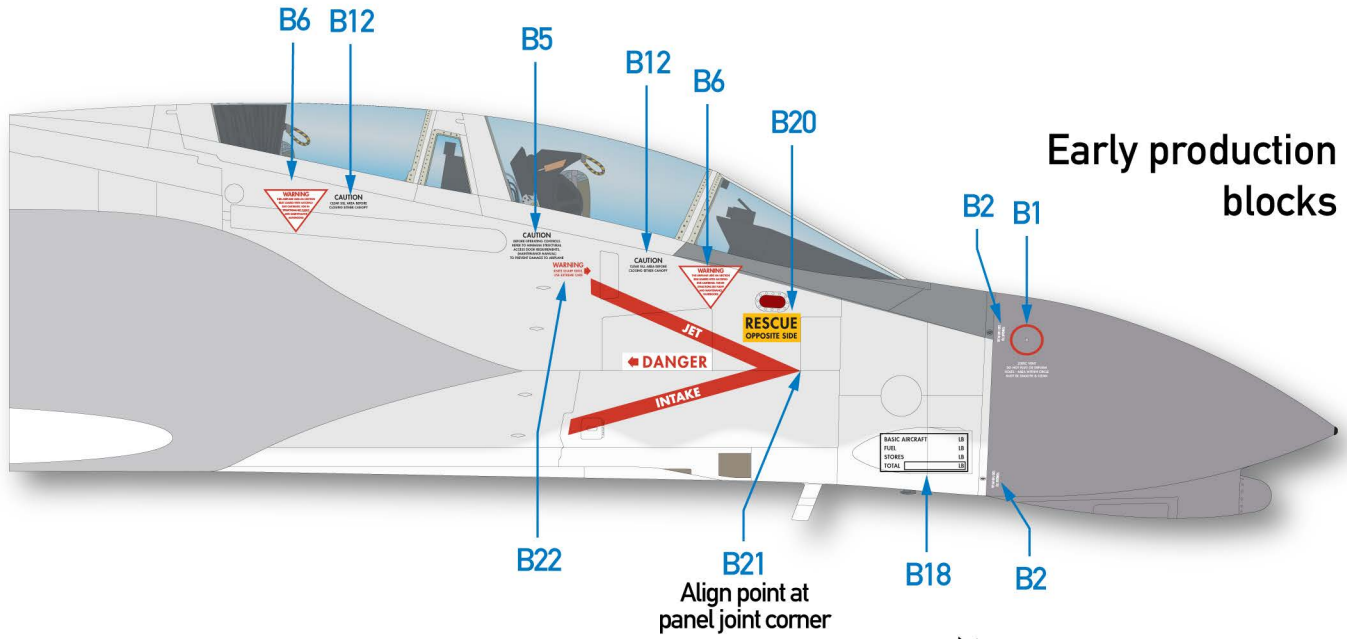

### Detail Note

The red refueling probe illumination light was fitted on the production line starting with Block 8 F4H-1s (BuNo 148411). It was retrofitted to earlier aircraft during depot overhaul.

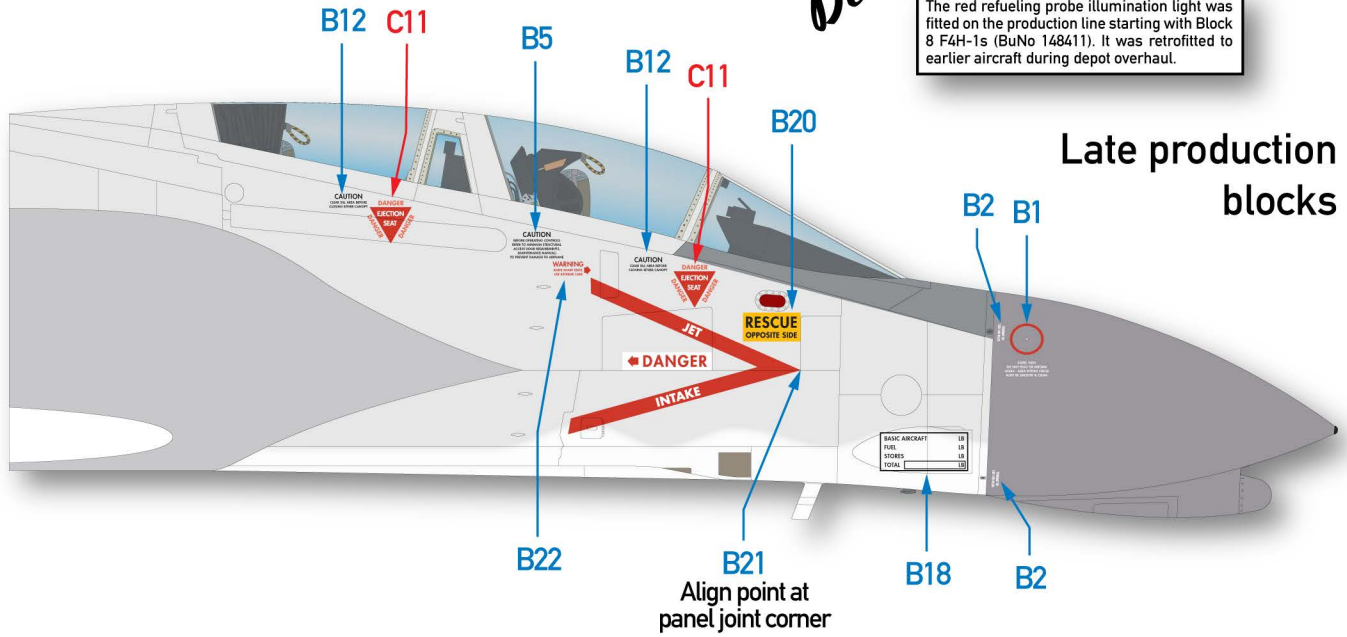



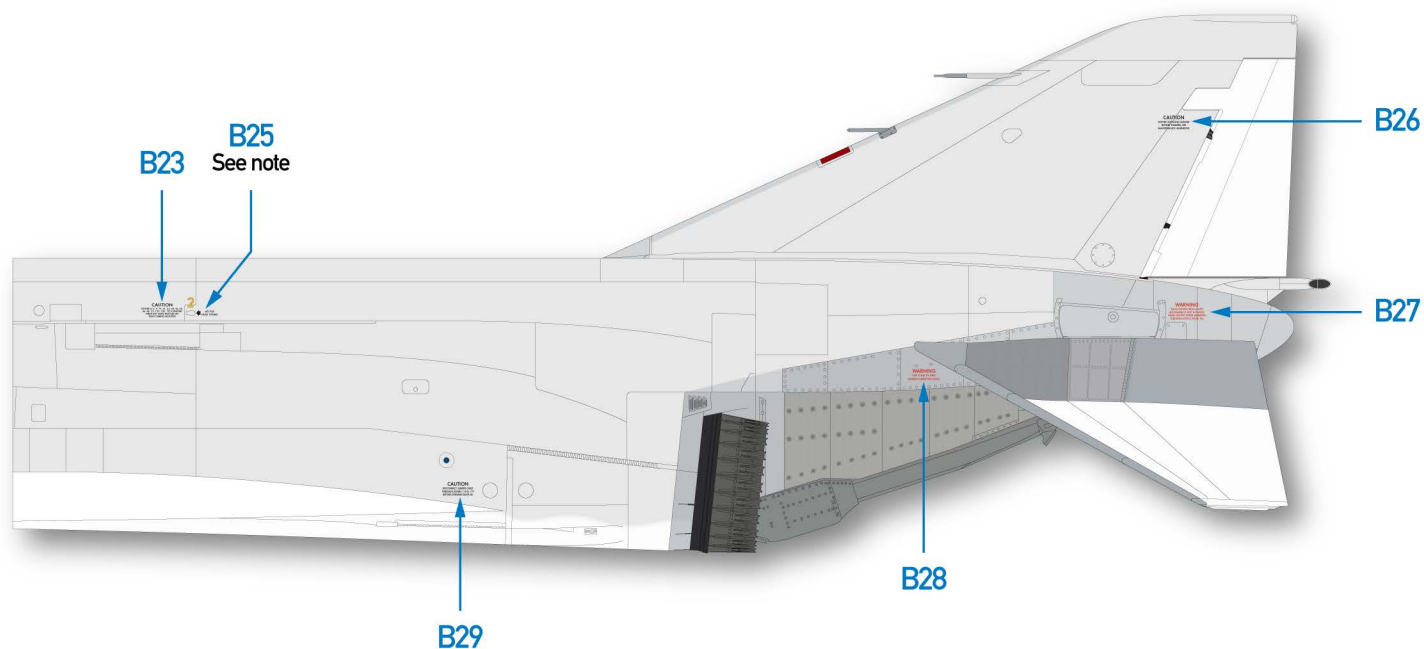
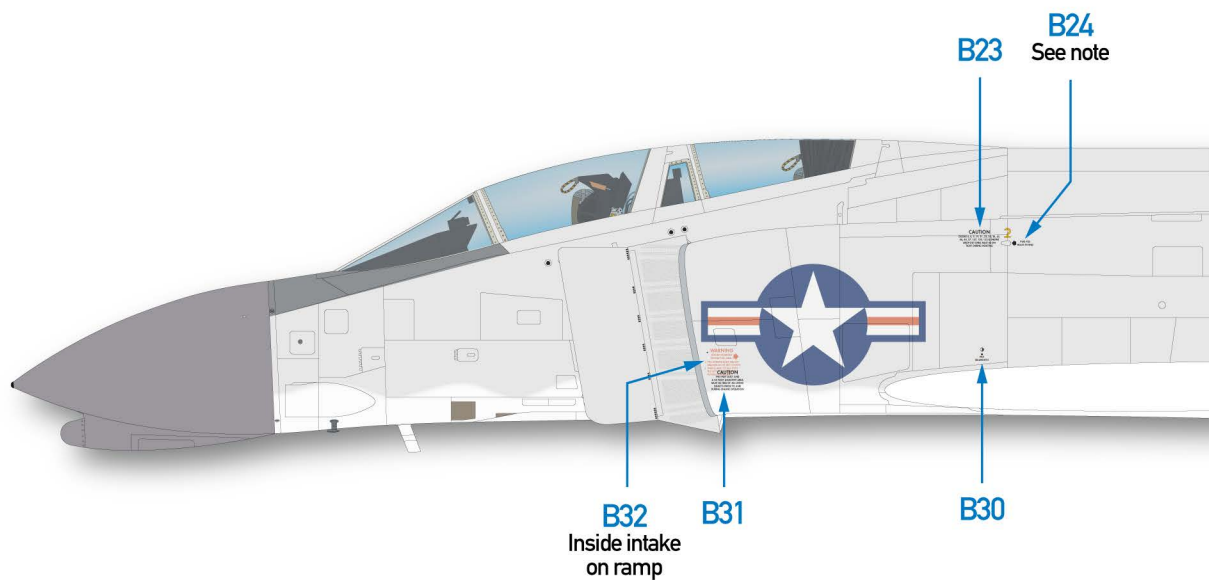

Note: On decals B24 and B25, the yellow hoisting hook symbol was not present on early F4H-1s and F-4Bs. It appeared sometime around 1965, but we have not been able to determine a precise production block or BuNo for its implementation. Trim the symbol off if you are building an early Phantom.

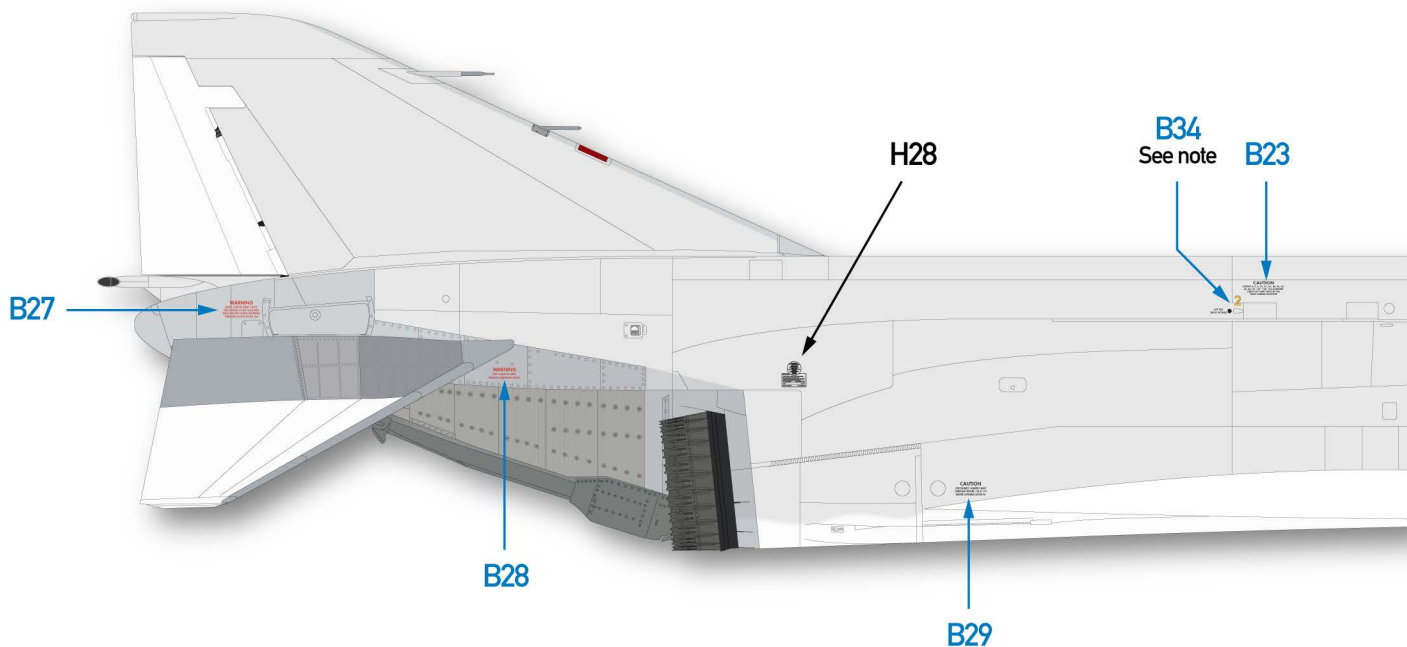
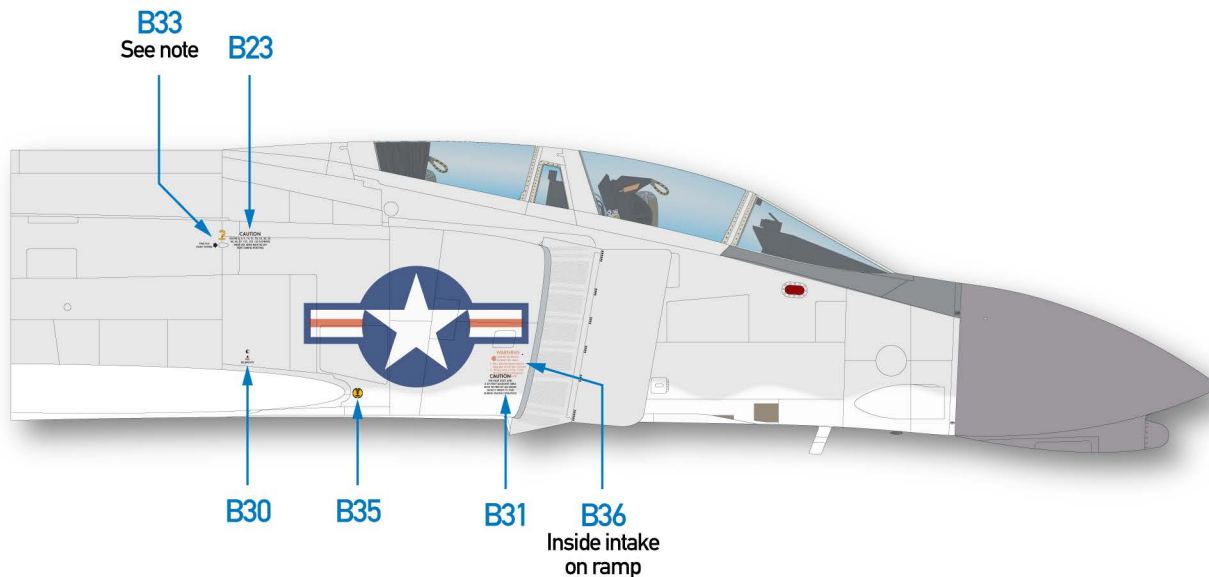

Note: On decals B33 and B34, the yellow hoisting hook symbol was not present on early F4H-1s and F-4Bs. It appeared sometime around 1965, but we have not been able to determine a precise production block or BuNo for its implementation. Trim the symbol off if you are building an early Phantom.

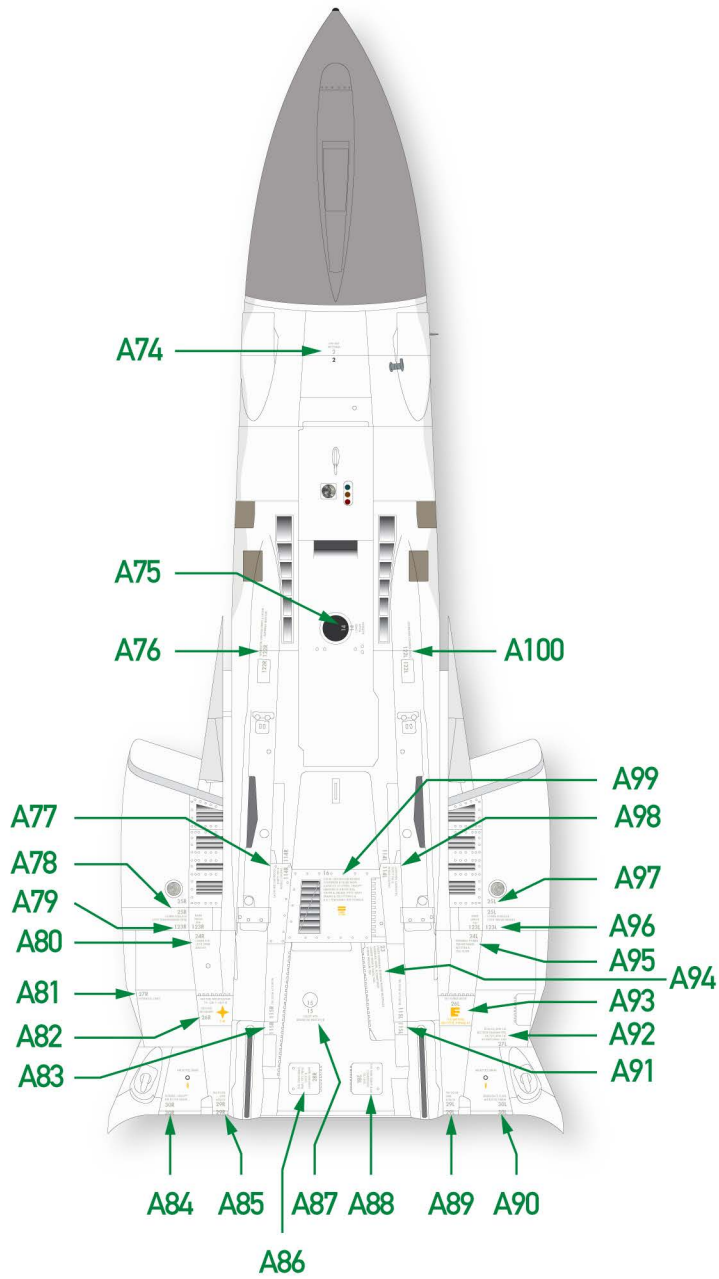

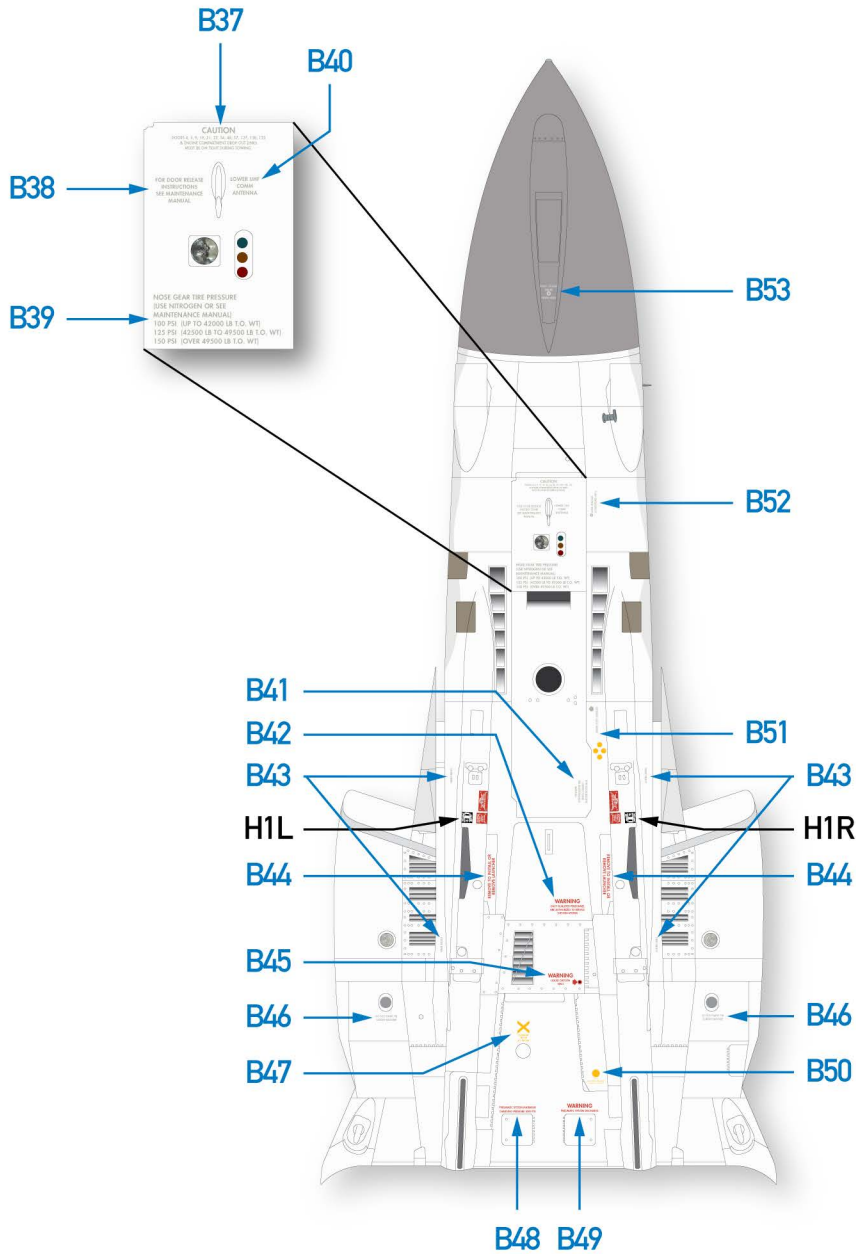



↑  
Forward

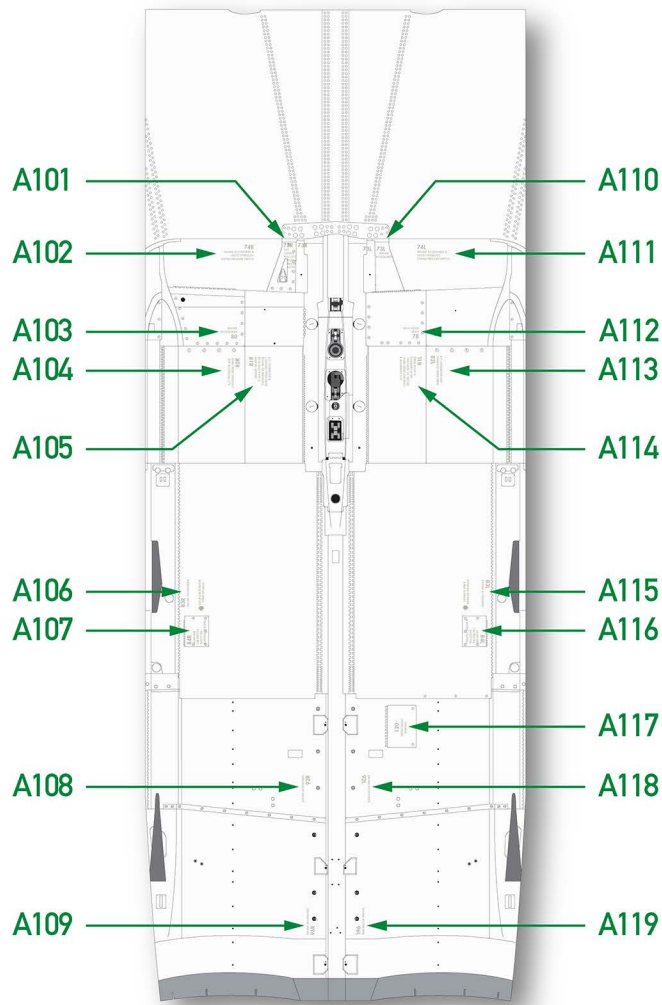

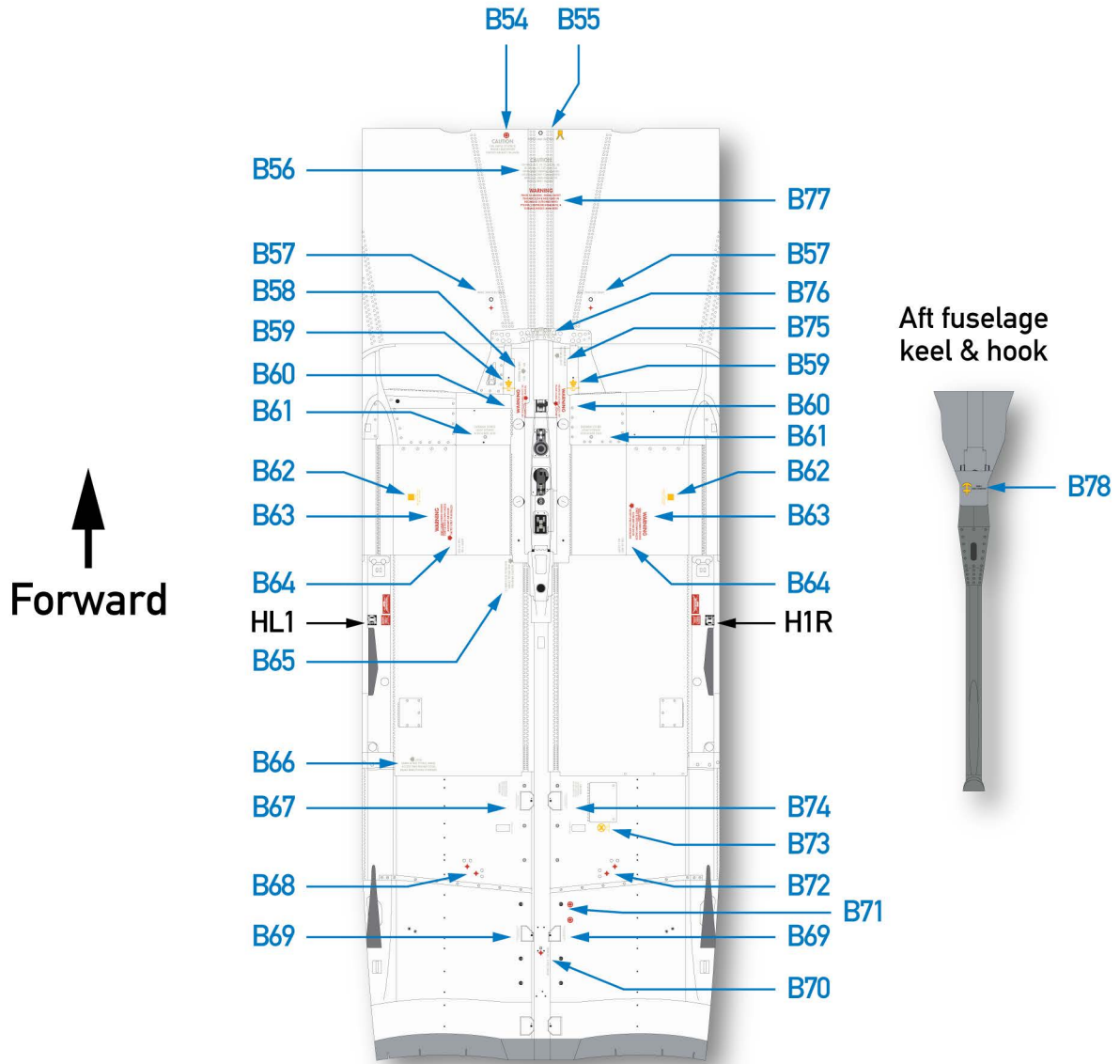

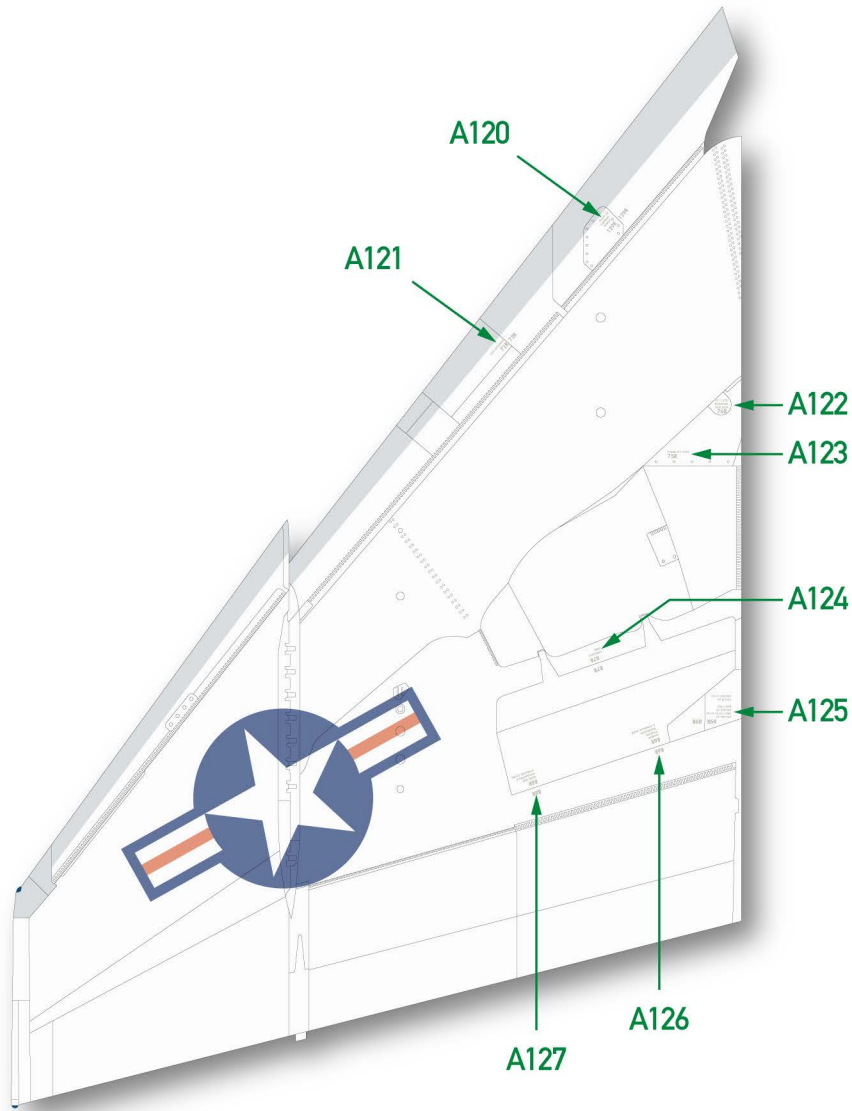

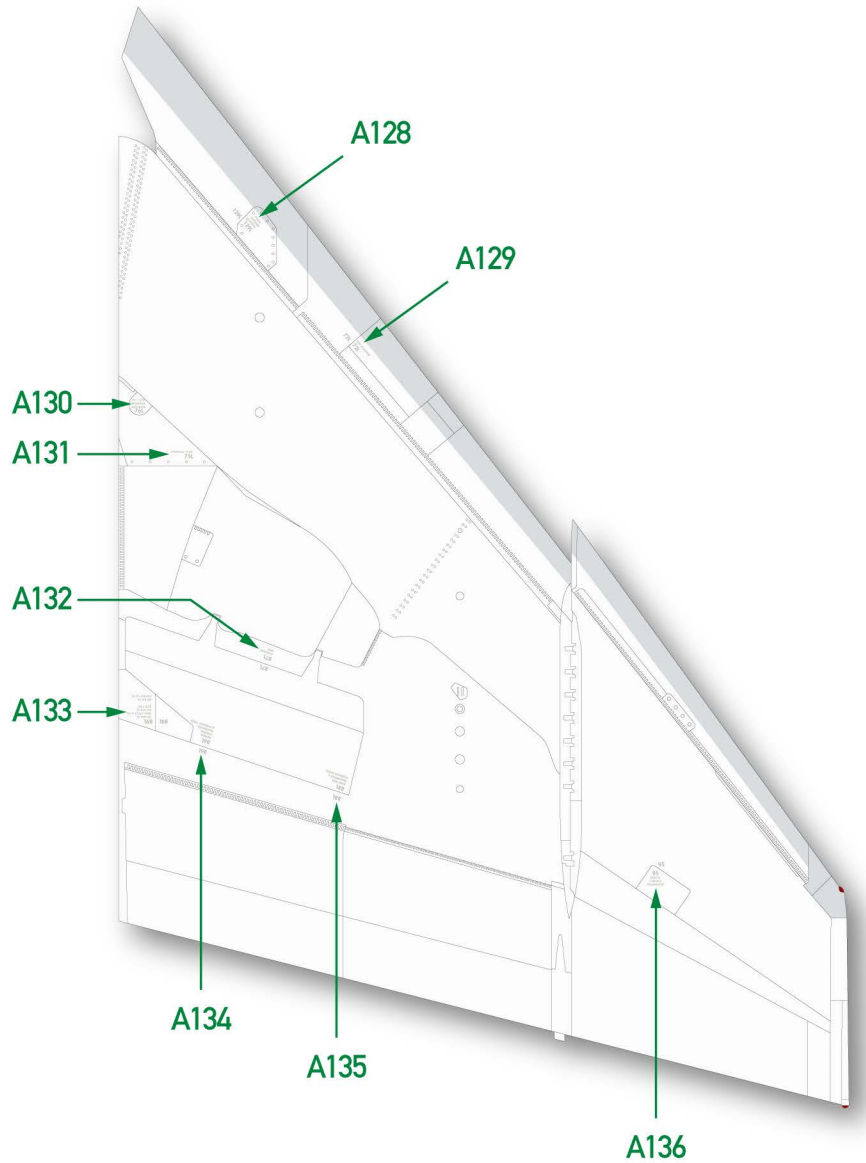



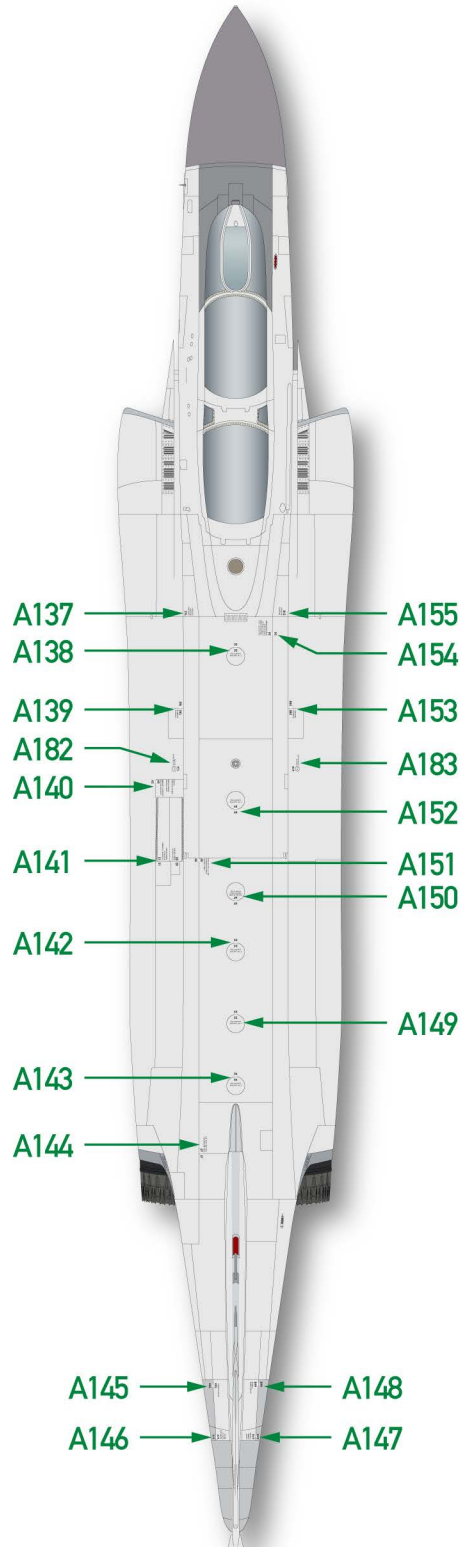

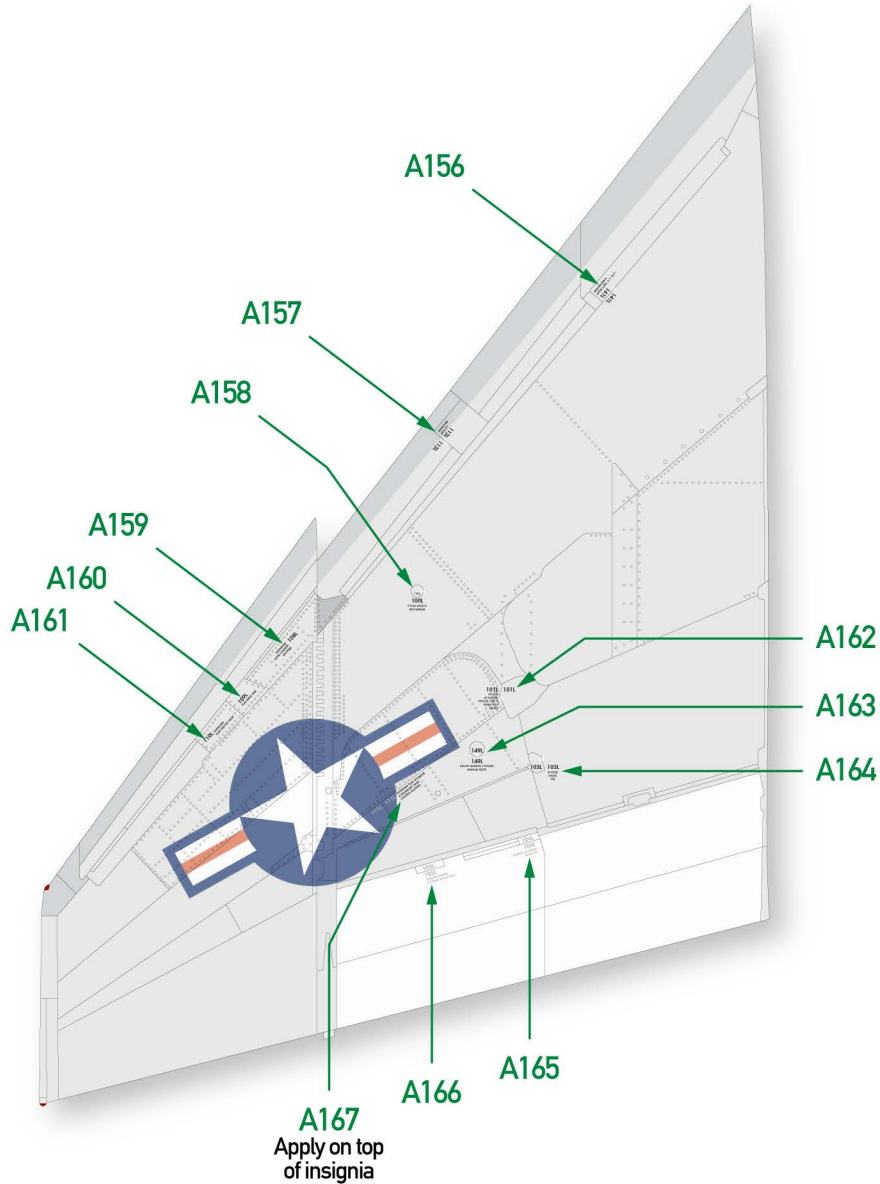

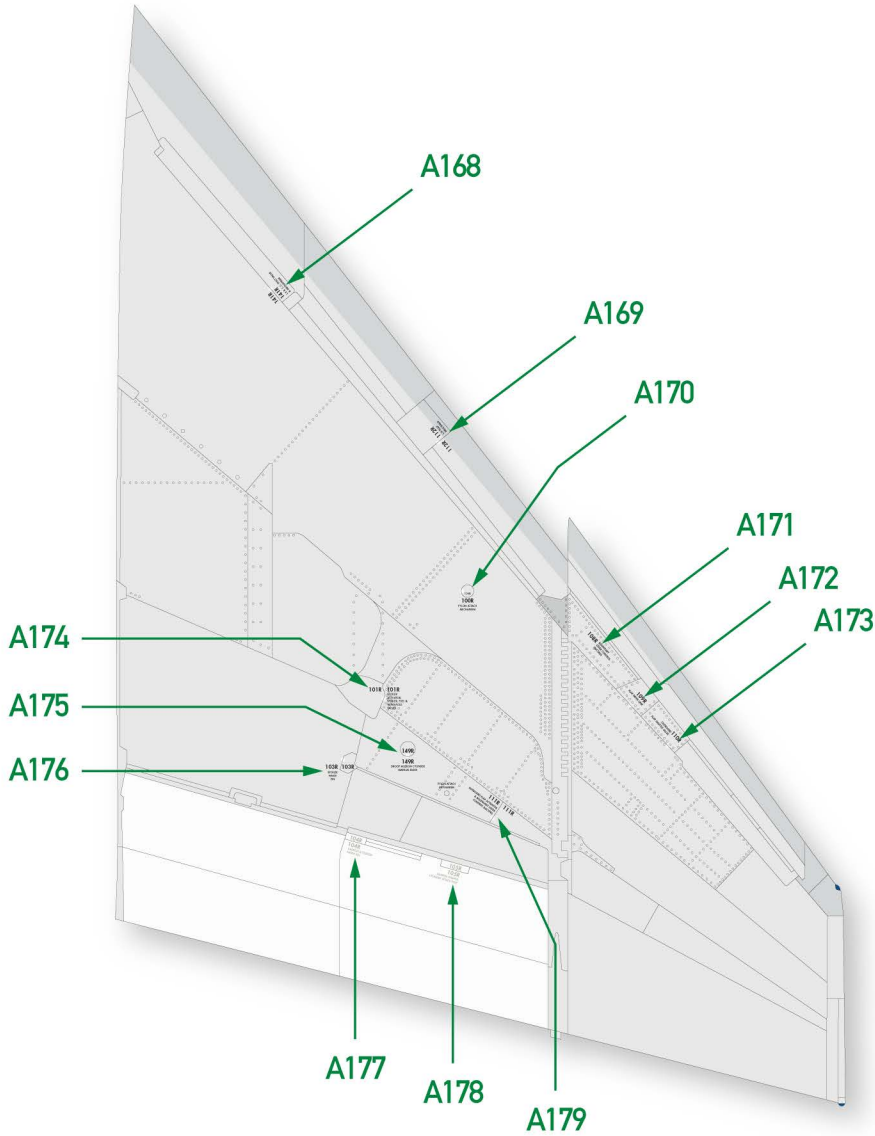

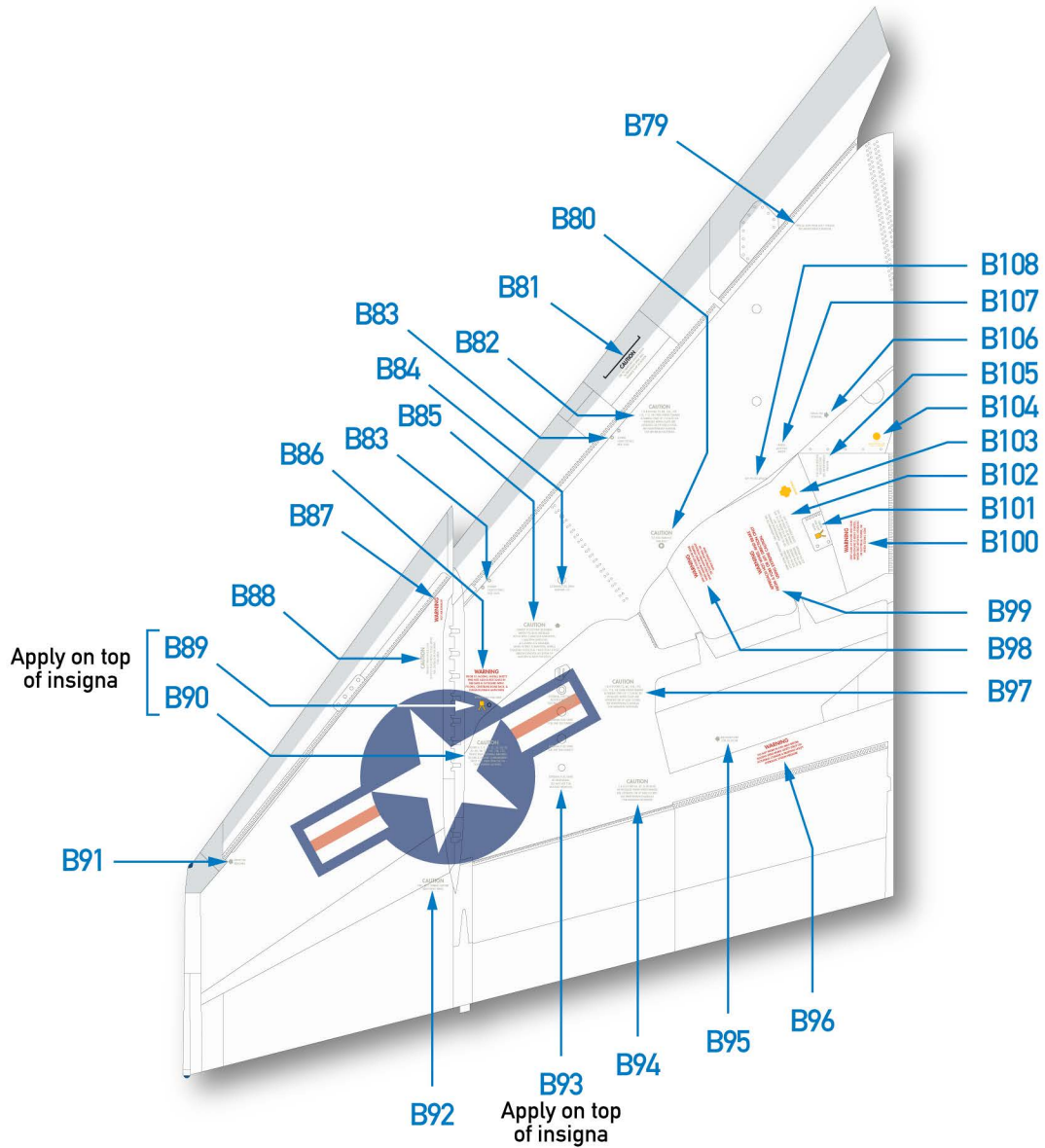



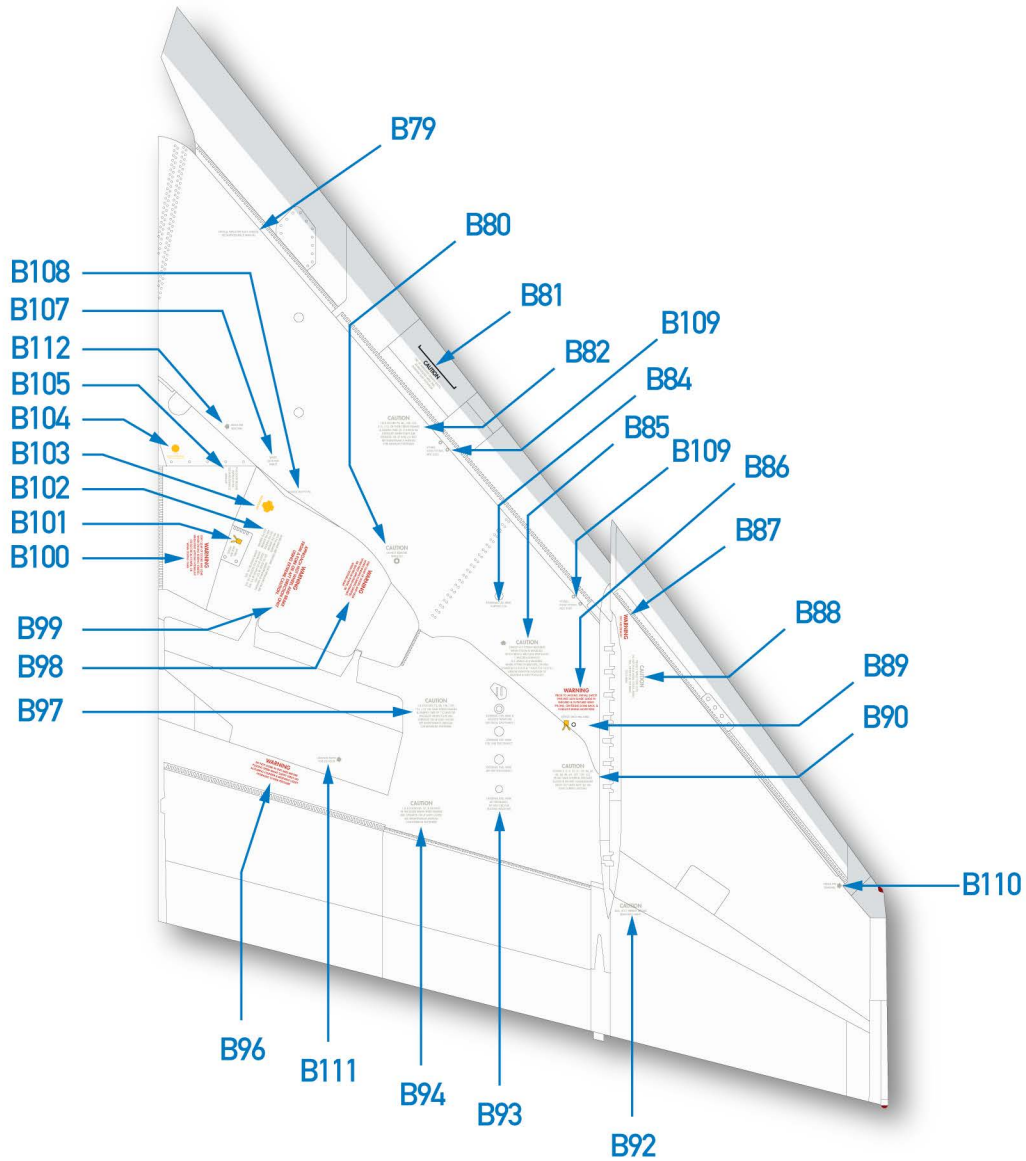

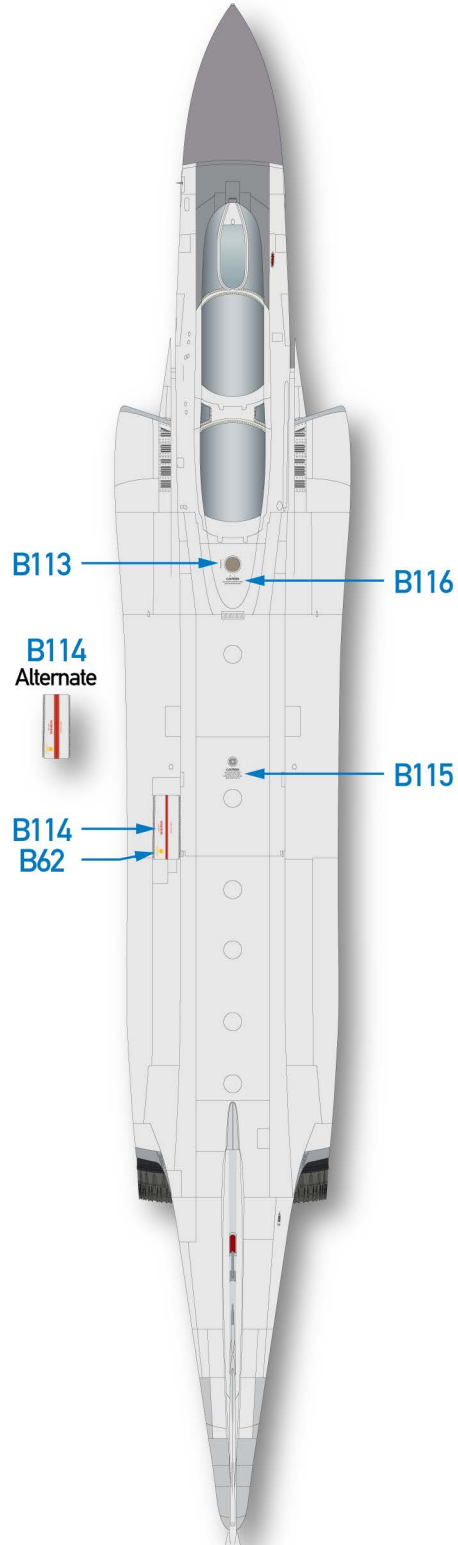

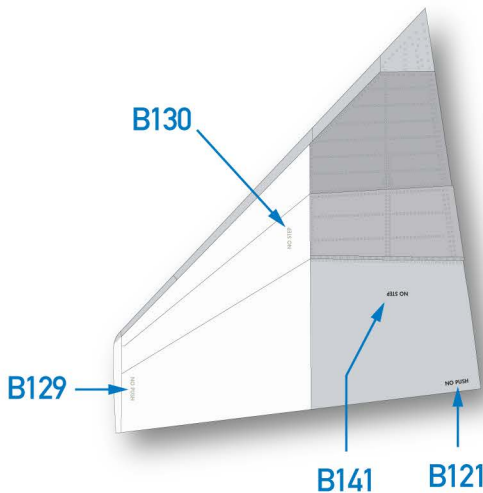
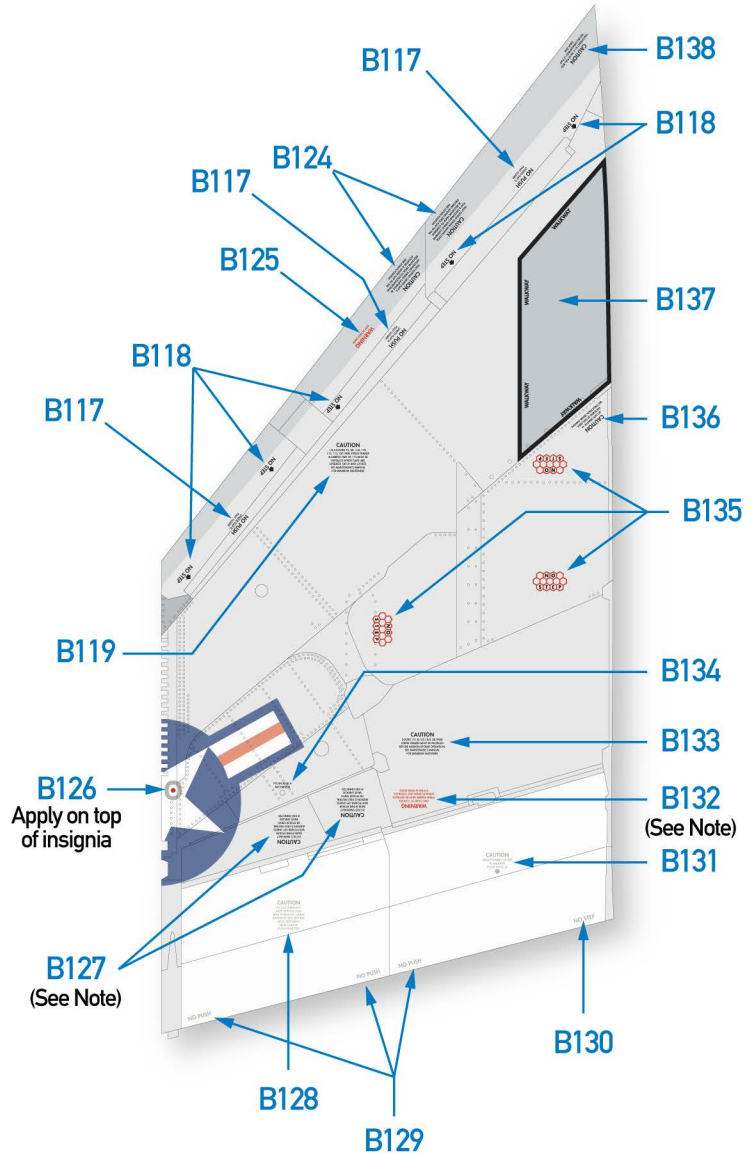
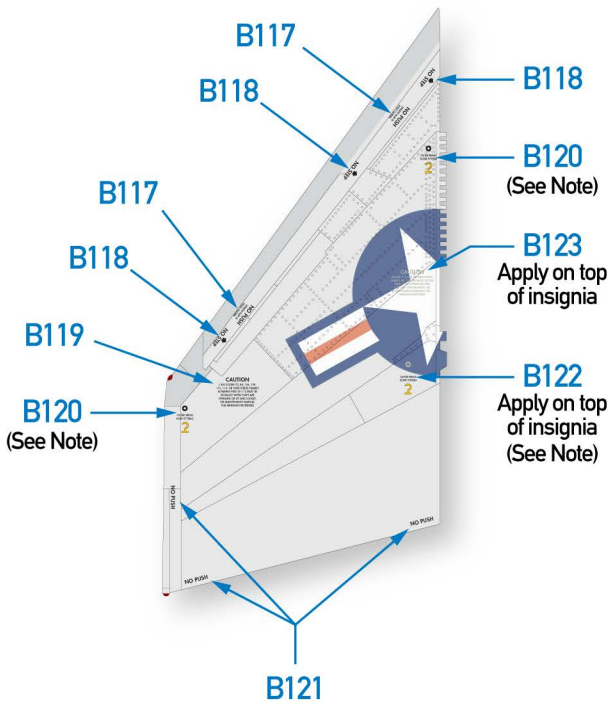

**Note:**

B127/B132: Note the orientation of these items. Tops of letters face the trailing edge of the wing.

B120/B122: The yellow hoisting hook symbol was not present on early F4H-1s and F-4Bs. It appeared sometime around 1965, but we have not been able to determine a precise production block or BuNo for its implementation. Trim the symbol off if you are building an early Phantom.

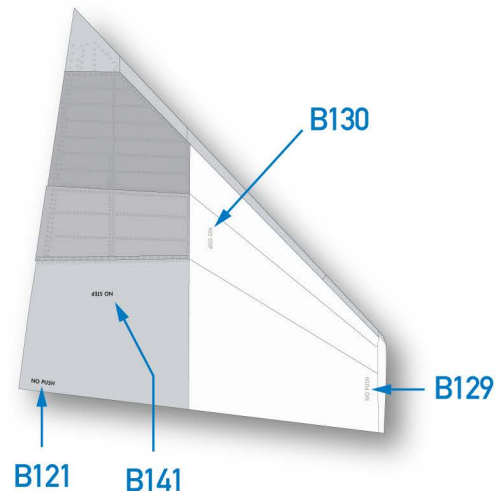
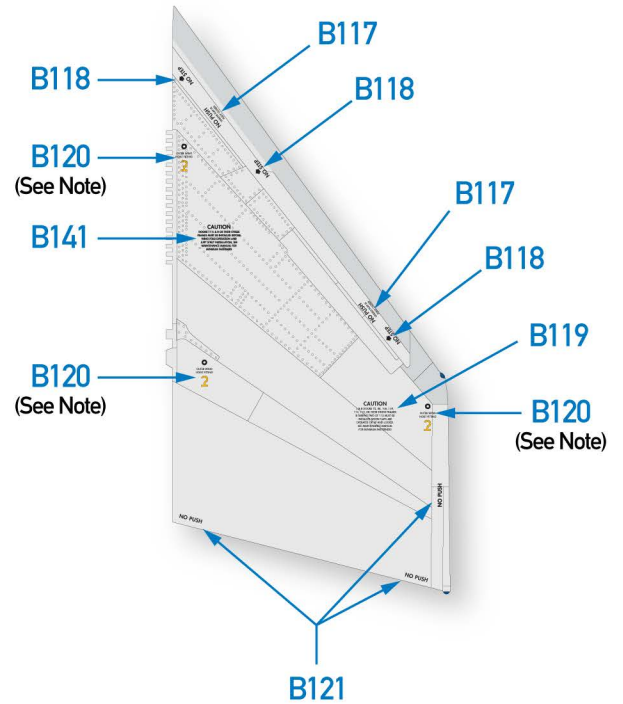
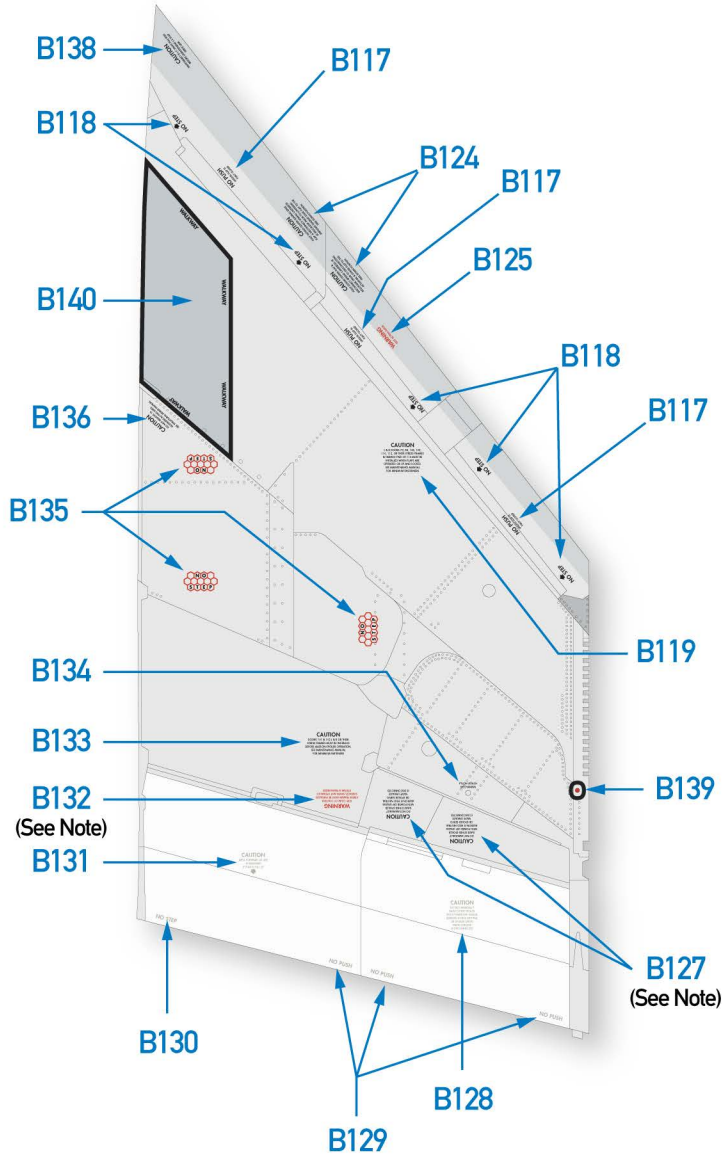

**Note:**

B127/B132: Note the orientation of these items. Tops of letters face the trailing edge of the wing.

B120: The yellow hoisting hook symbol was not present on early F4H-1s and F-4Bs. It appeared sometime around 1965, but we have not been able to determine a precise production block or BuNo for its implementation. Trim the symbol off if you are building an early Phantom.



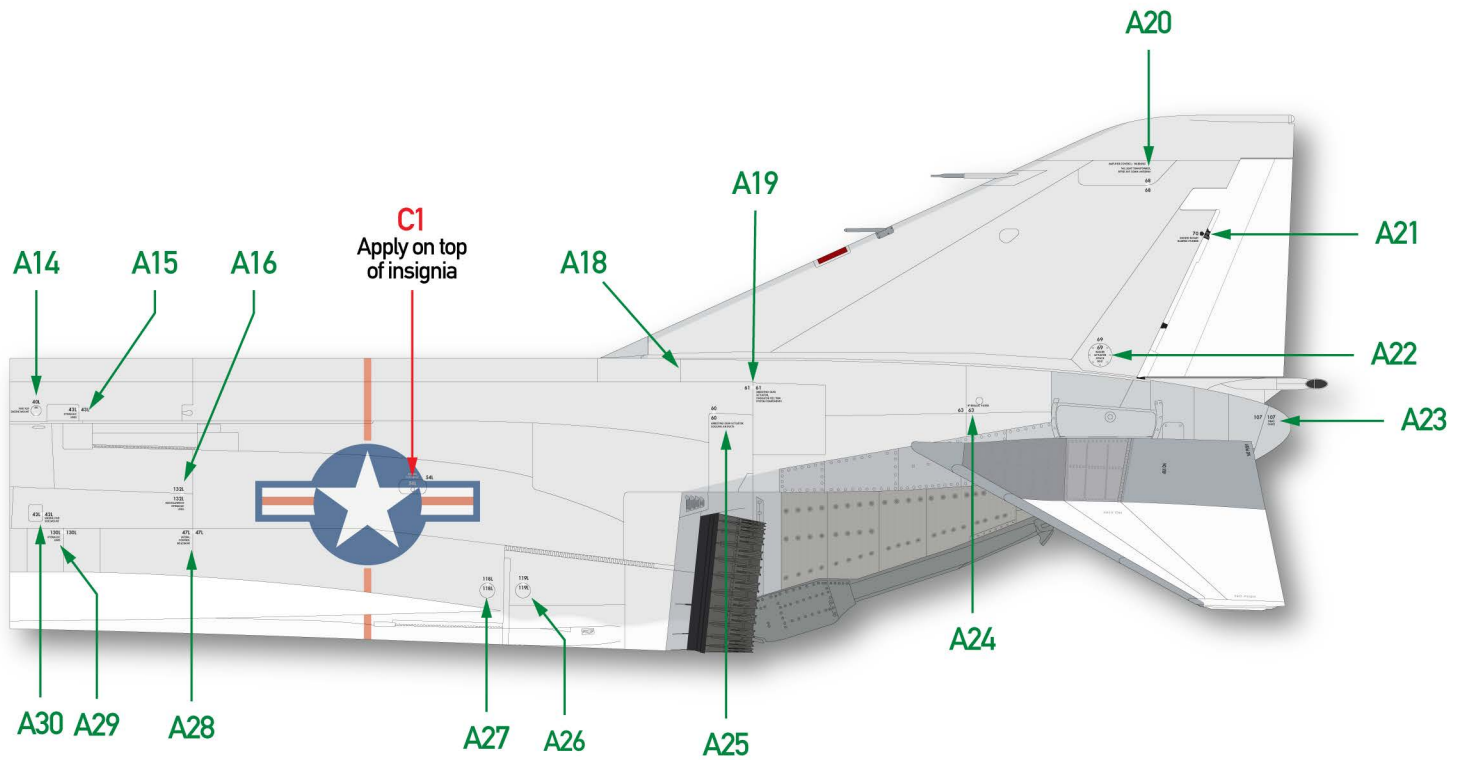
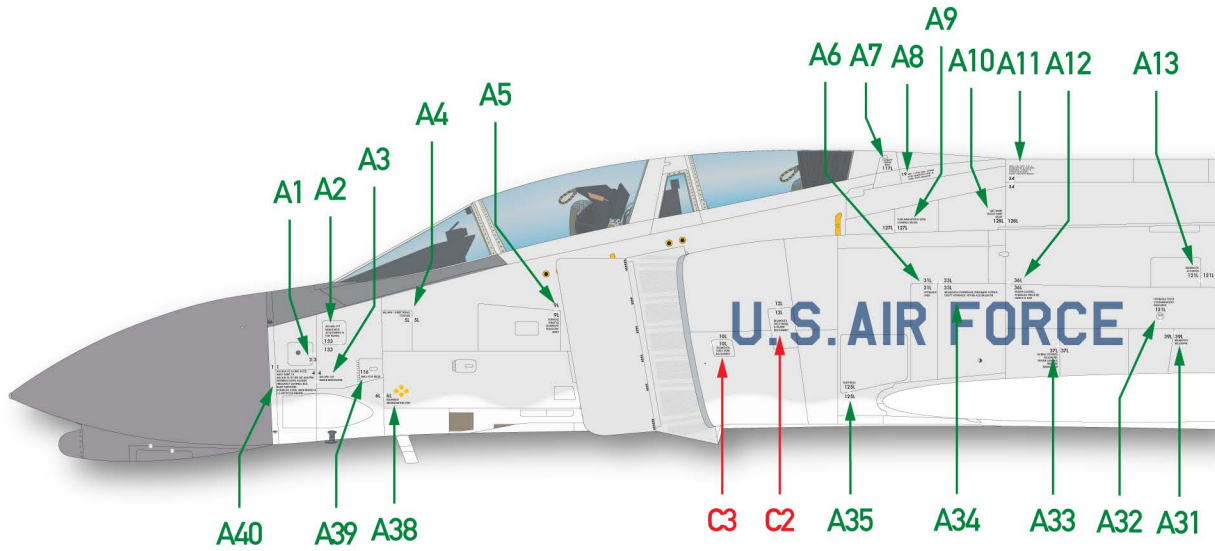

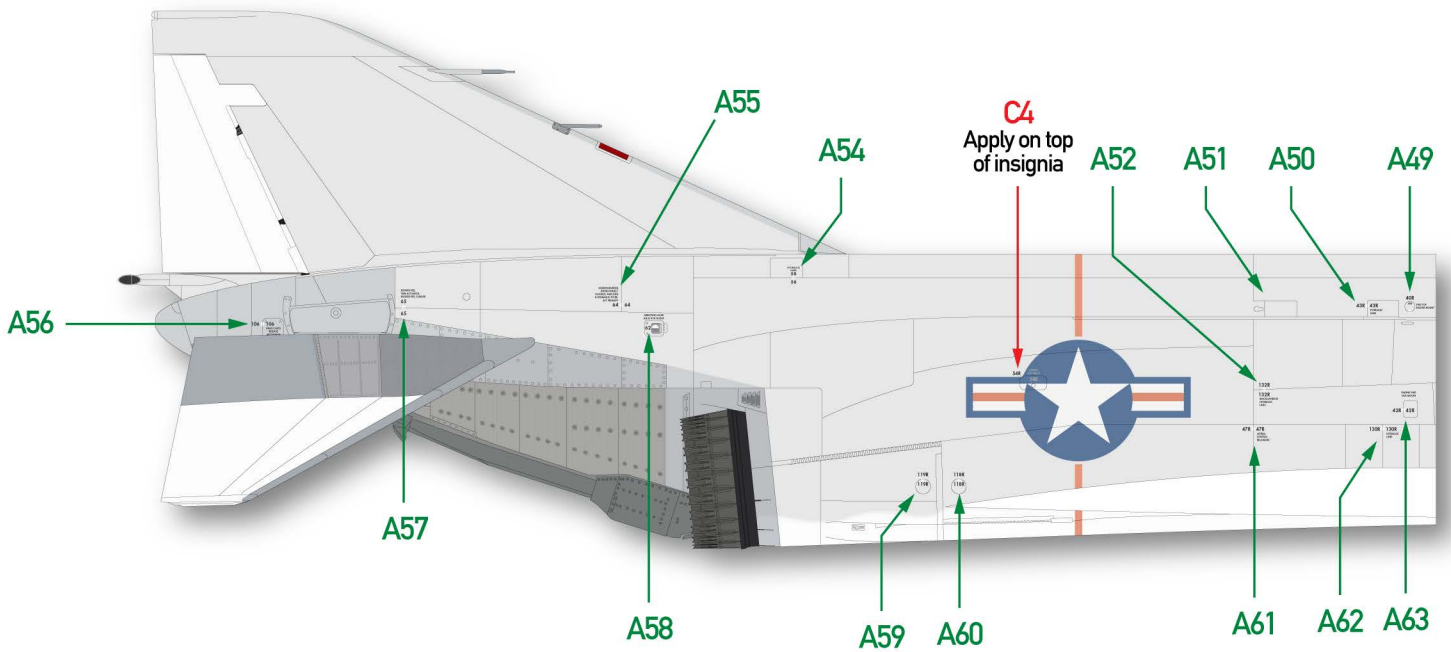
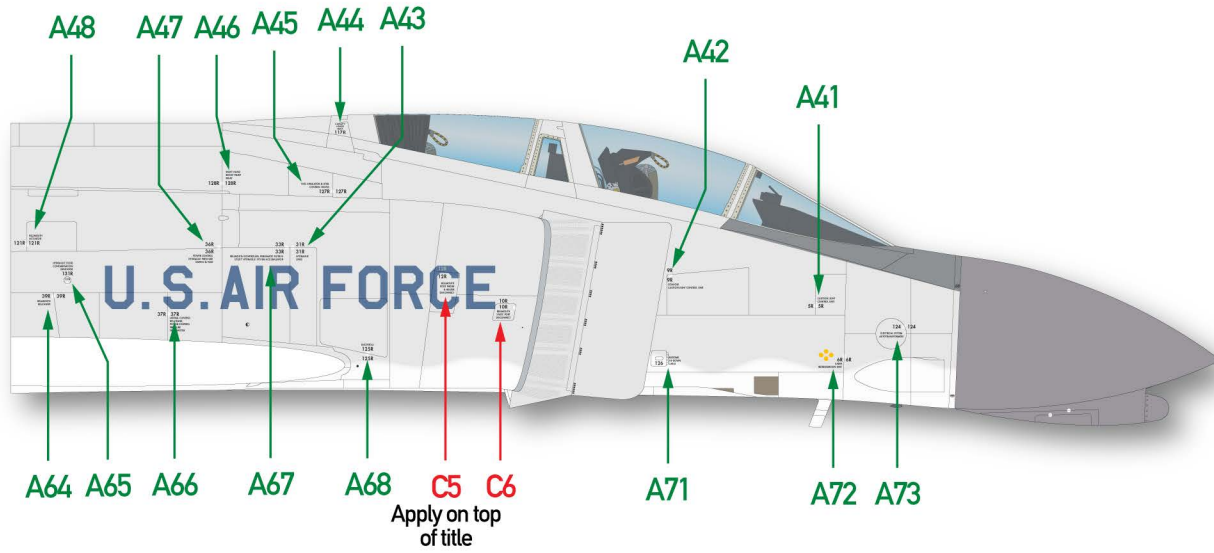

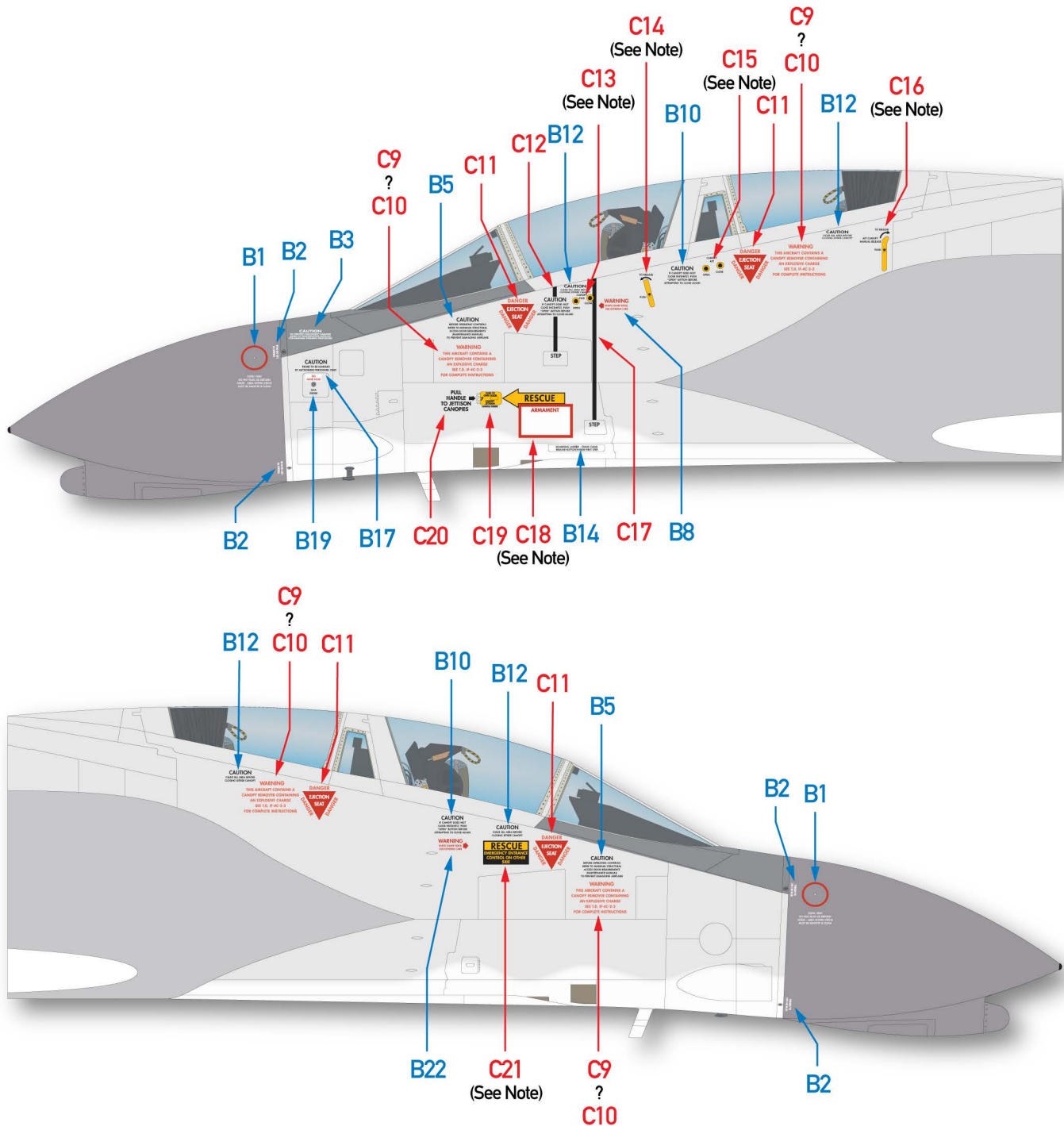

### Notes:

C9/C10: The salmon colored stencil (C9) was most commonly used, but the bright red version (C10) was also applied on some aircraft.

C13 - C16: Canopy open/close buttons & handles are provided to fit the ZM and Tamiya kit scribing (as closely as can make them), as well as in the actual scale size and shape based on tracings and measurements of these items on an actual F-4. The kit scribing (on every existing 1/48 F-4 kit we have found) is not really accurate in size or shape. We recommend filling the scribed detail and using the "B" versions of these decals, which are accurate scale representations of the real thing.

C18: The red and white armament placard was not originally applied on early Light Gull Gray/white F-4Cs. We believe the decal may have been supplied with the aircraft, but not applied at the factory. This is the most common location, but others were seen as well.

C21: Two variations are provided. The one shown in the drawing is by far the most common.

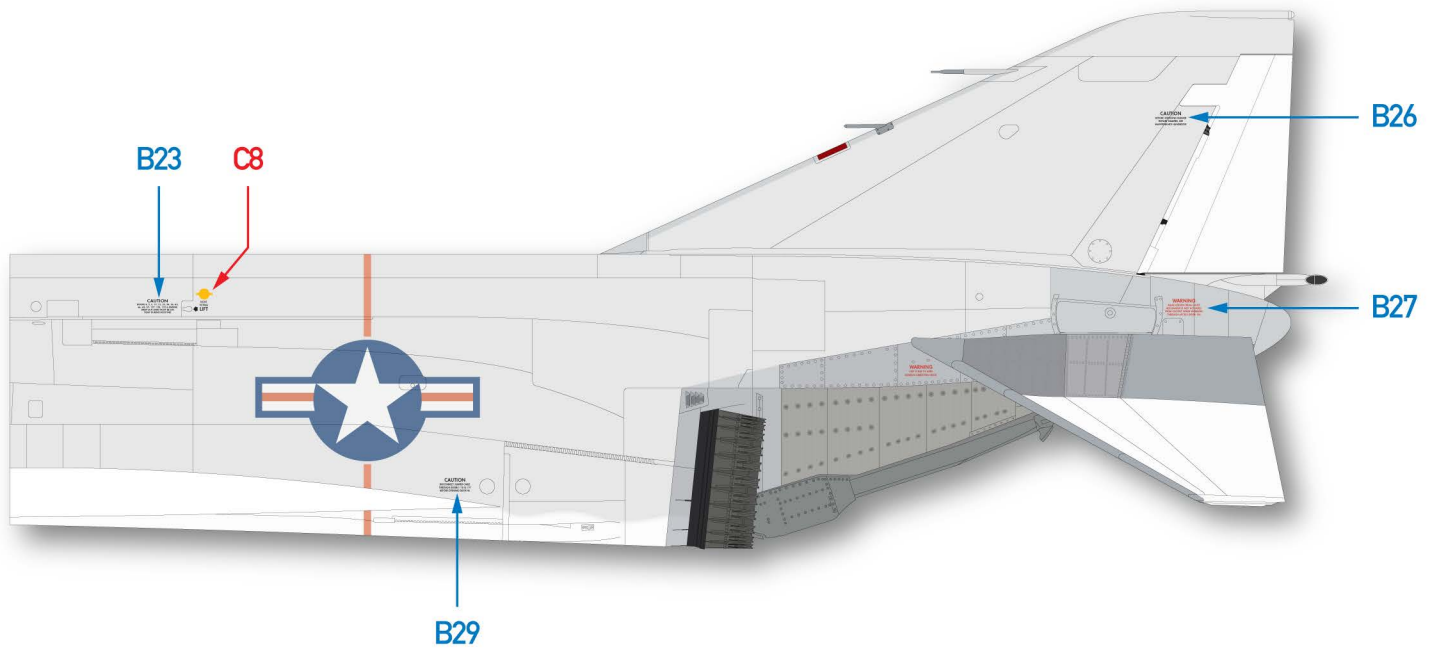
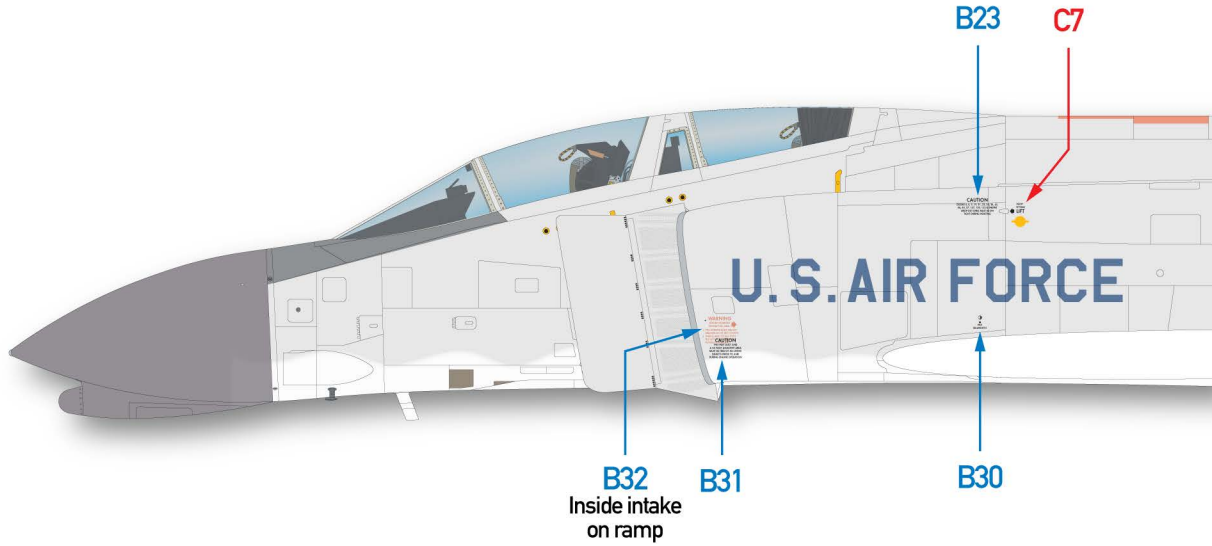



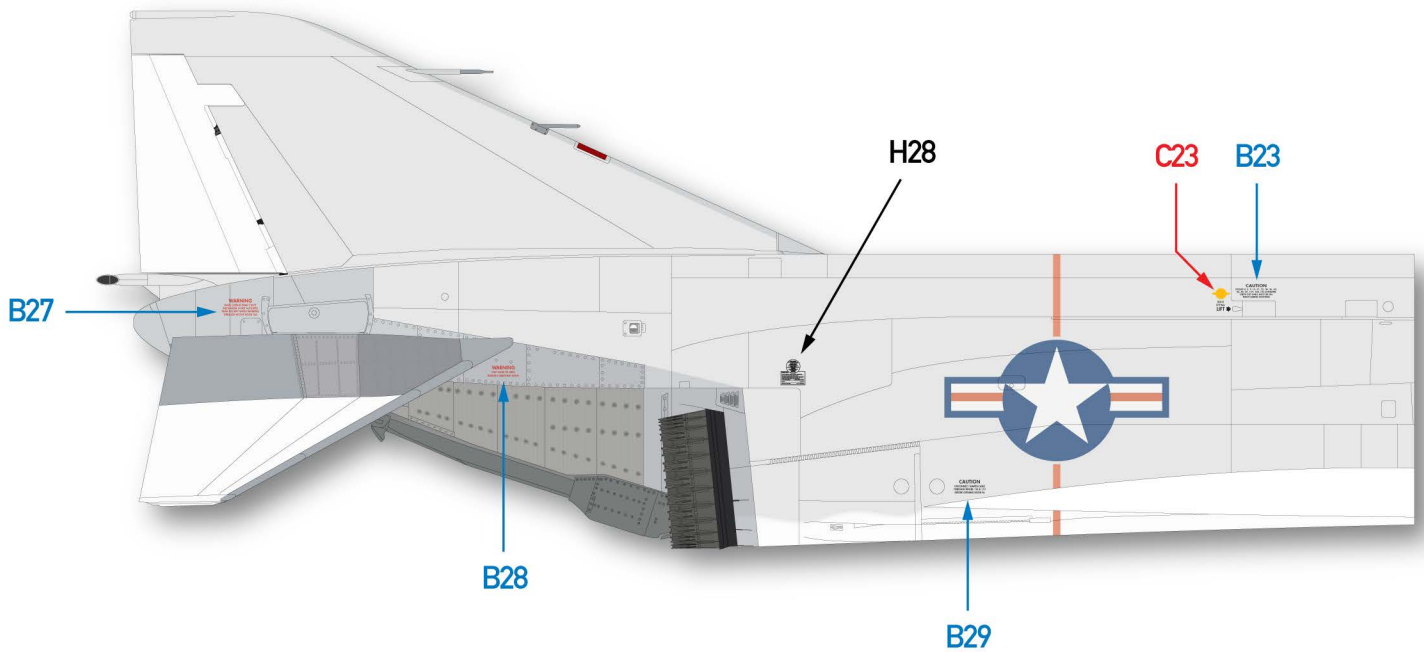
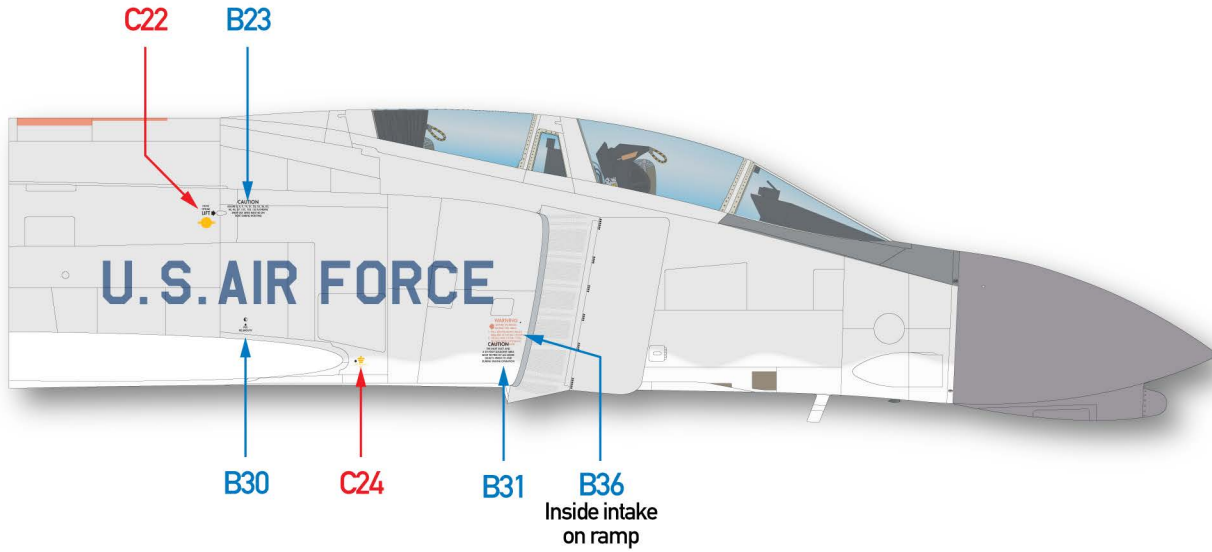



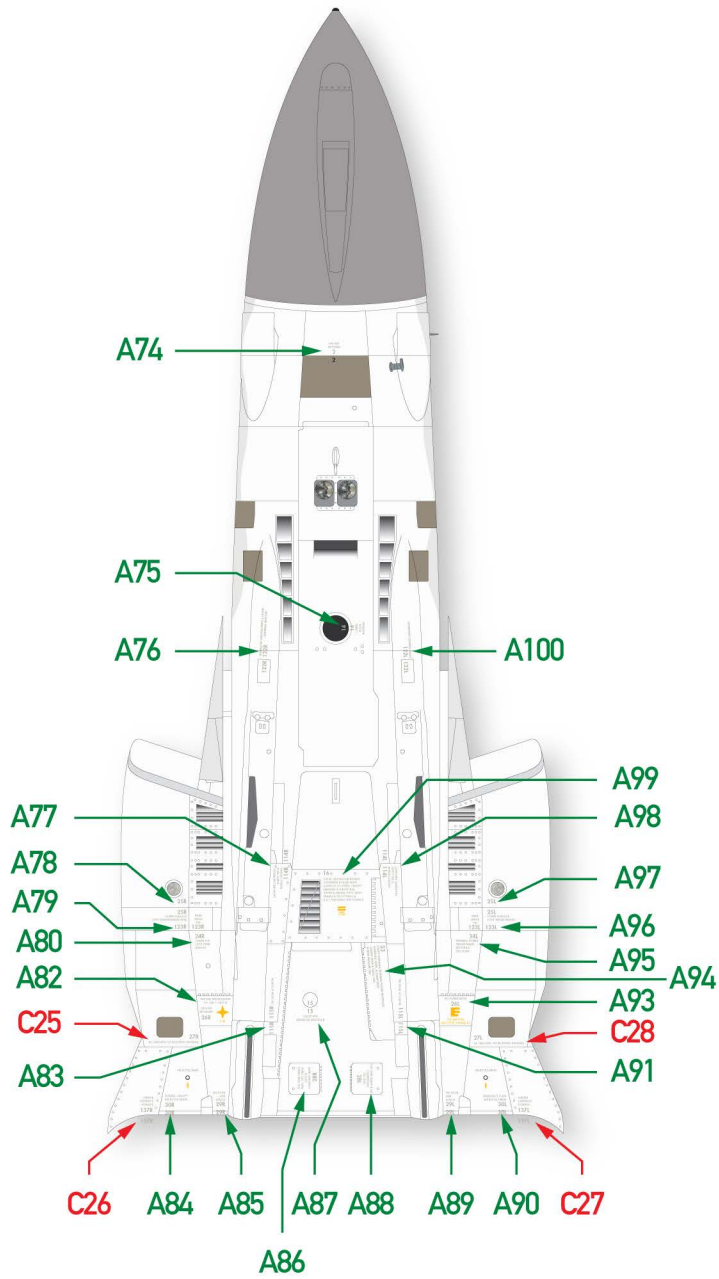

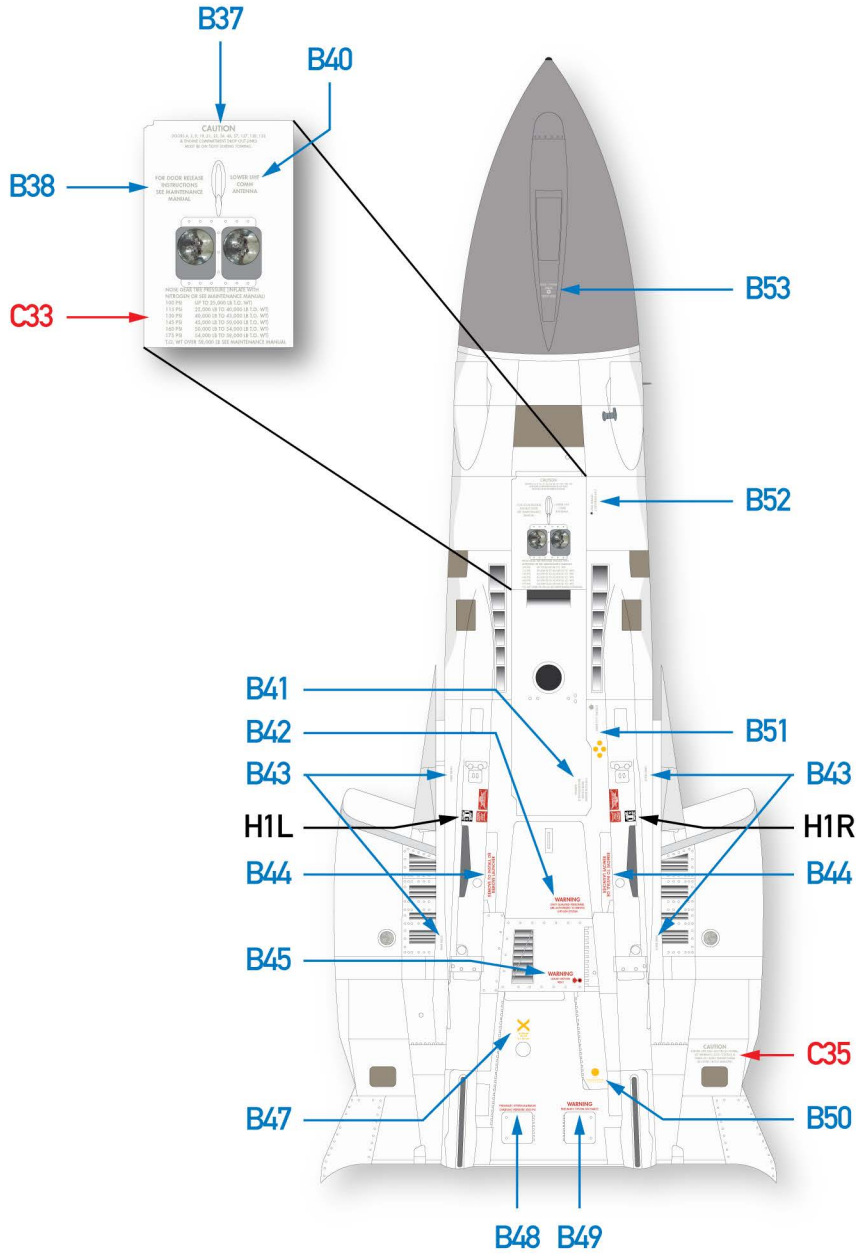

Note: Decal C34 omitted intentionally

↑  
Forward

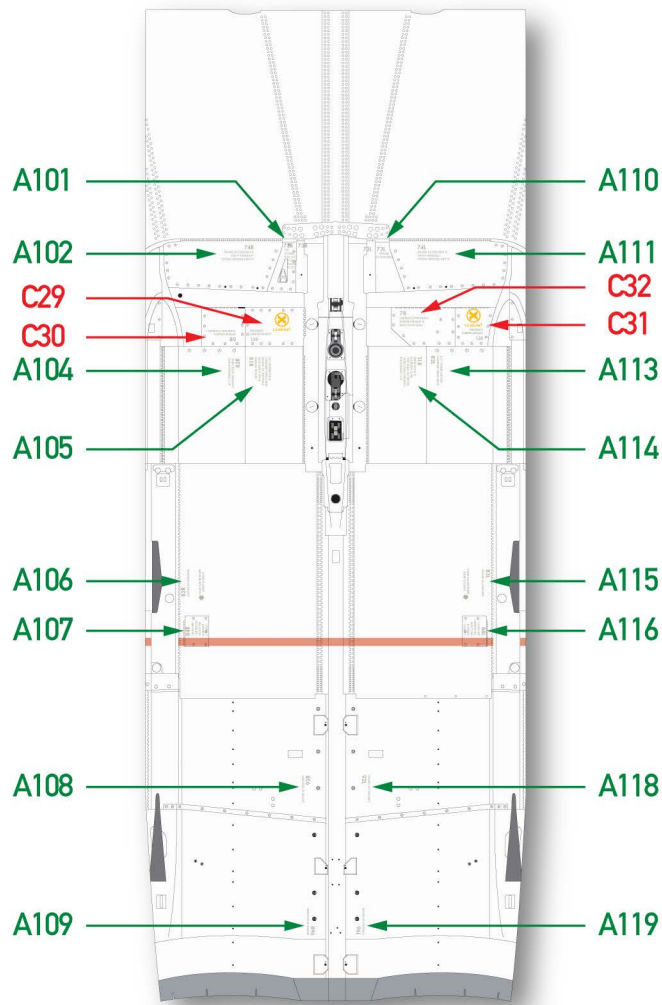

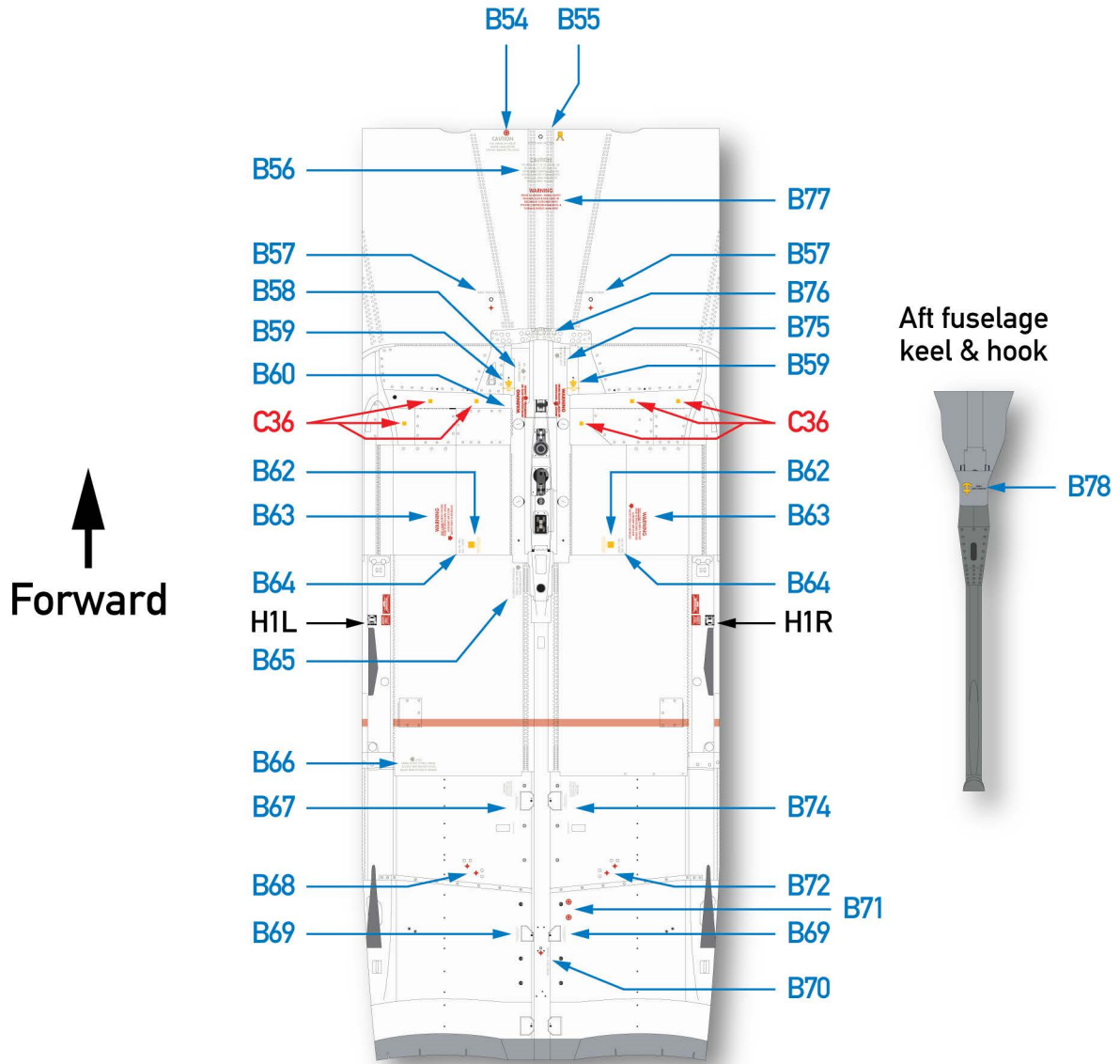

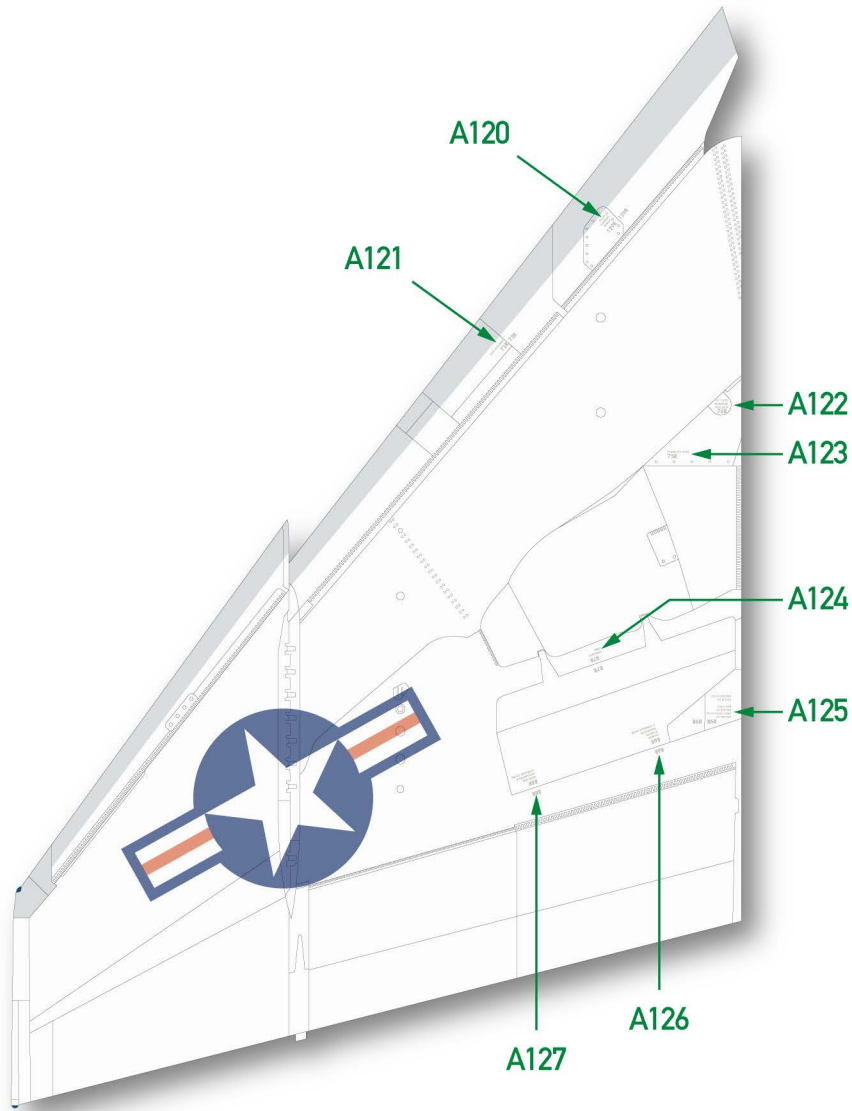



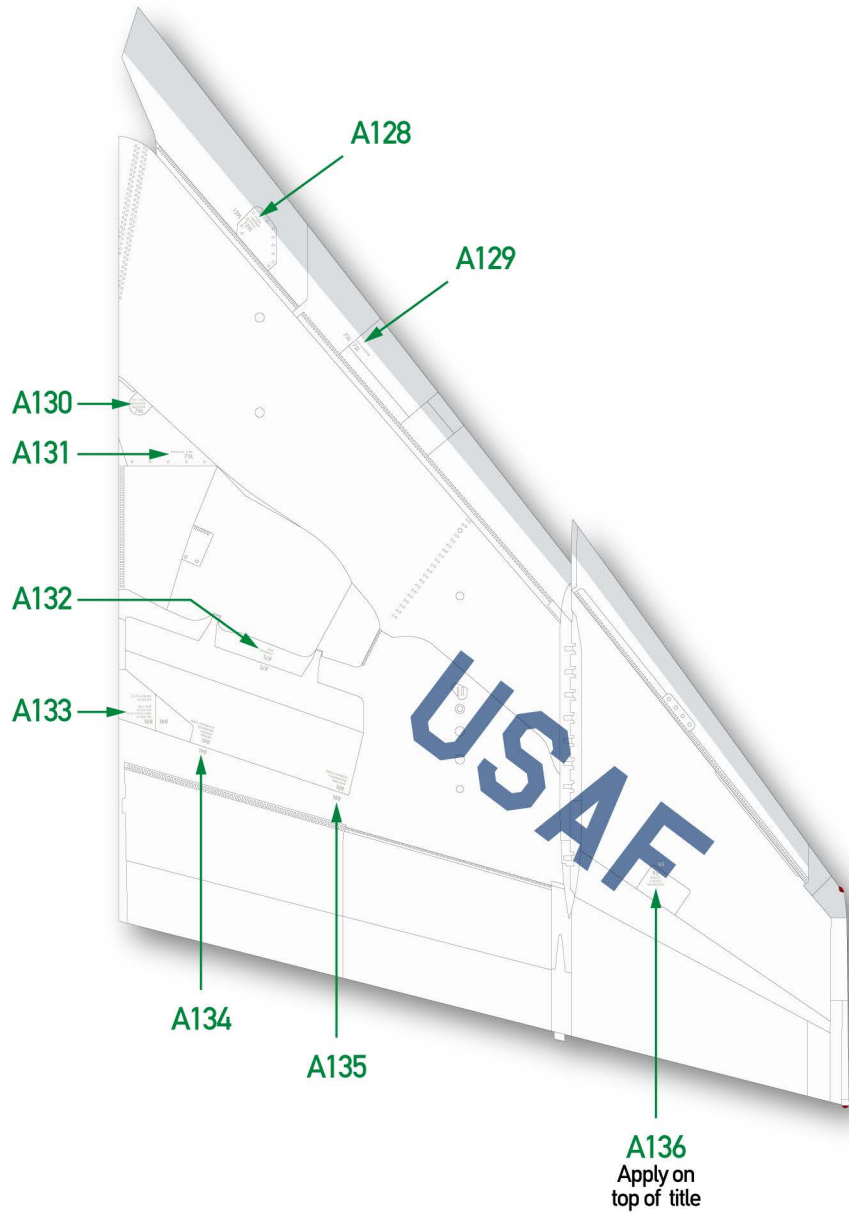

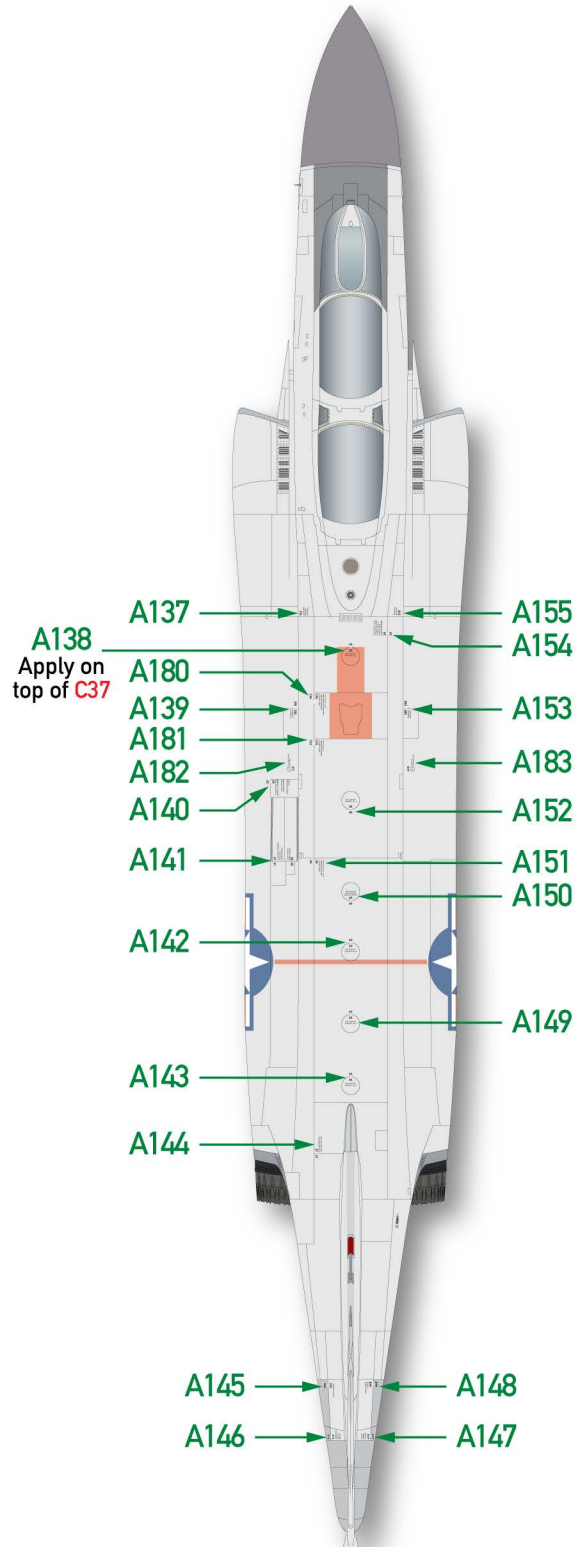

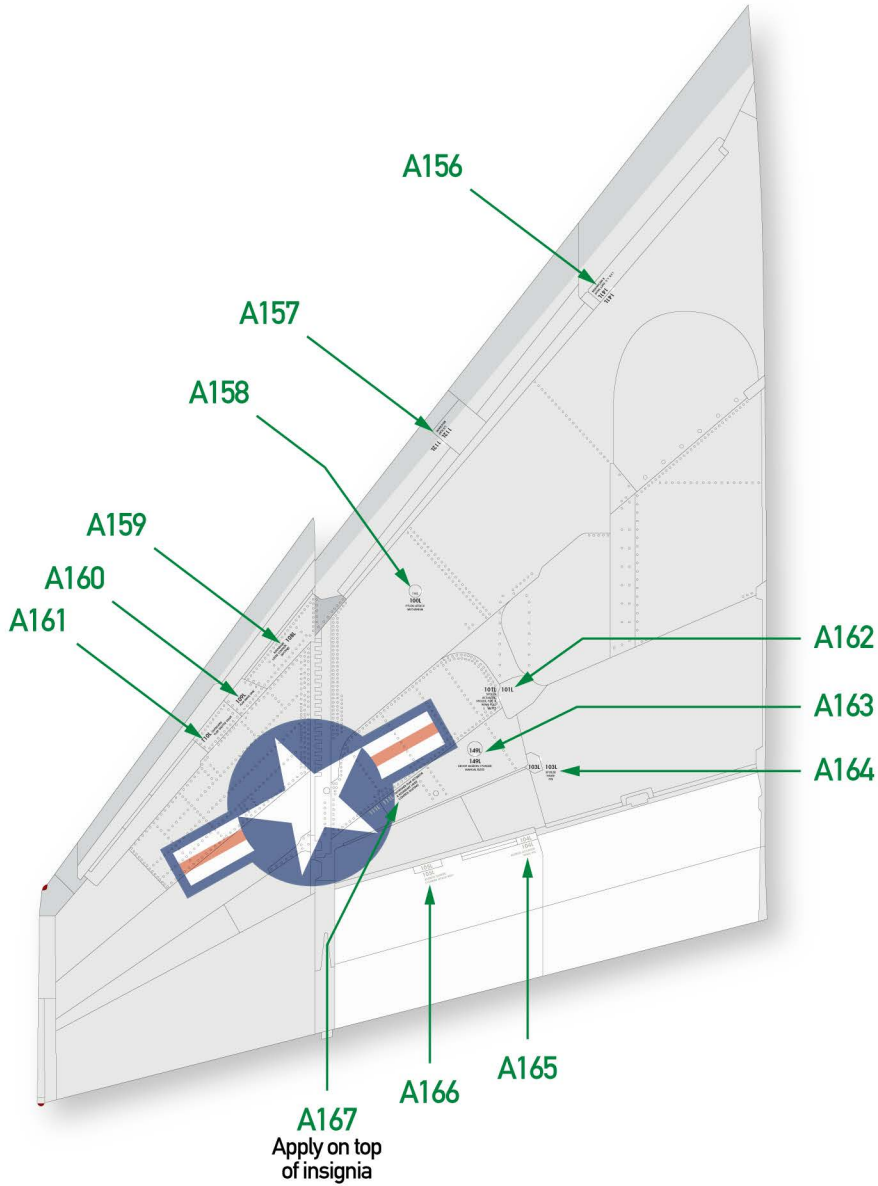

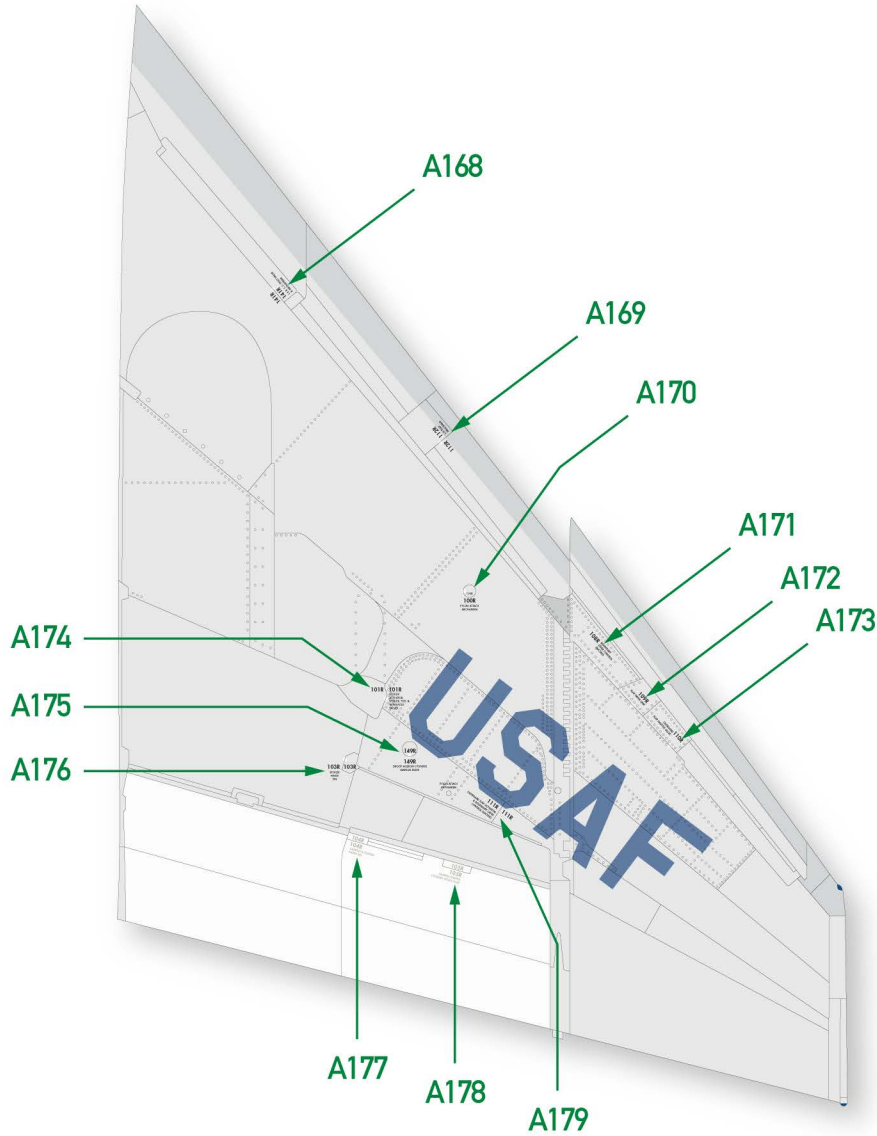

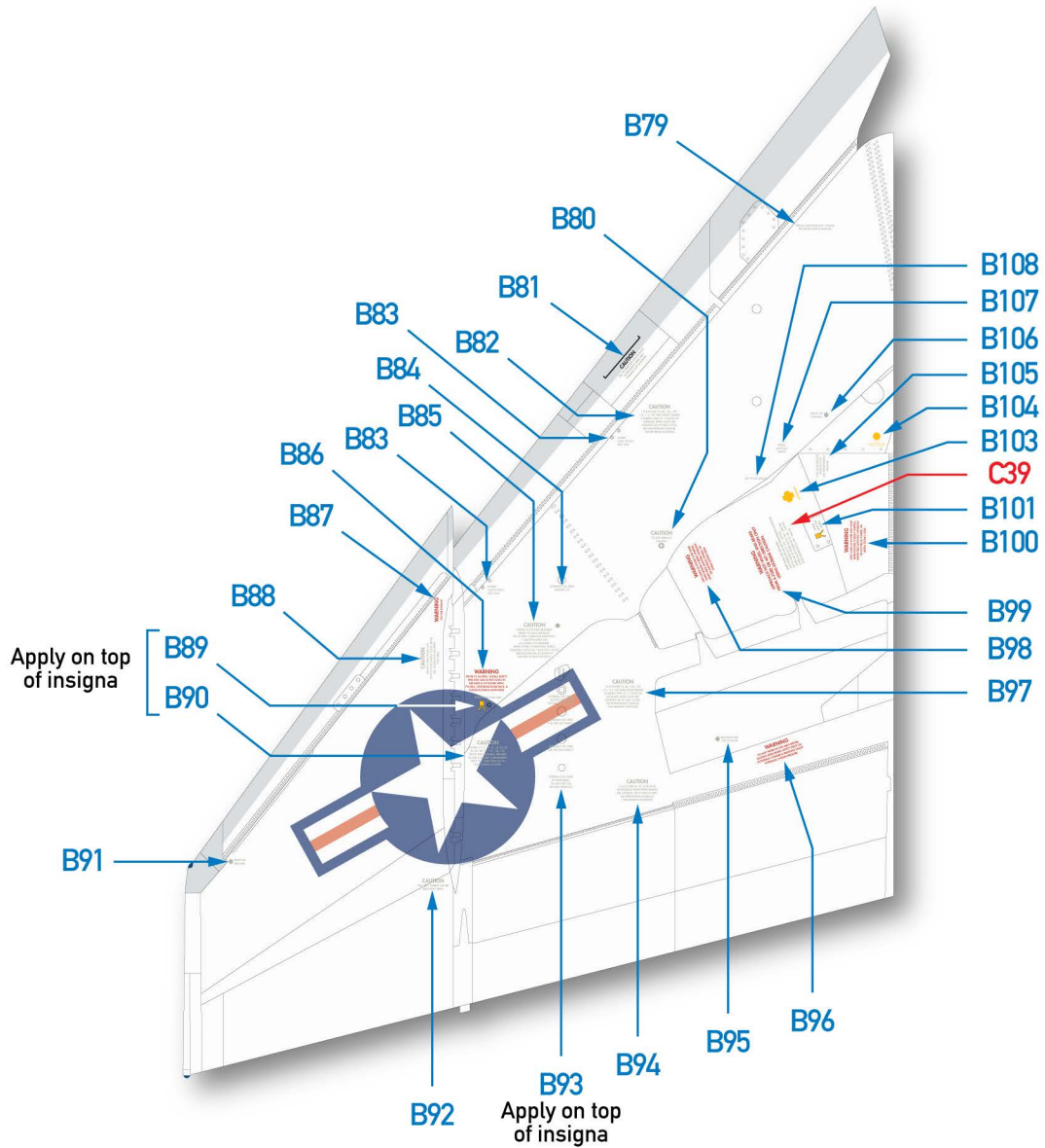



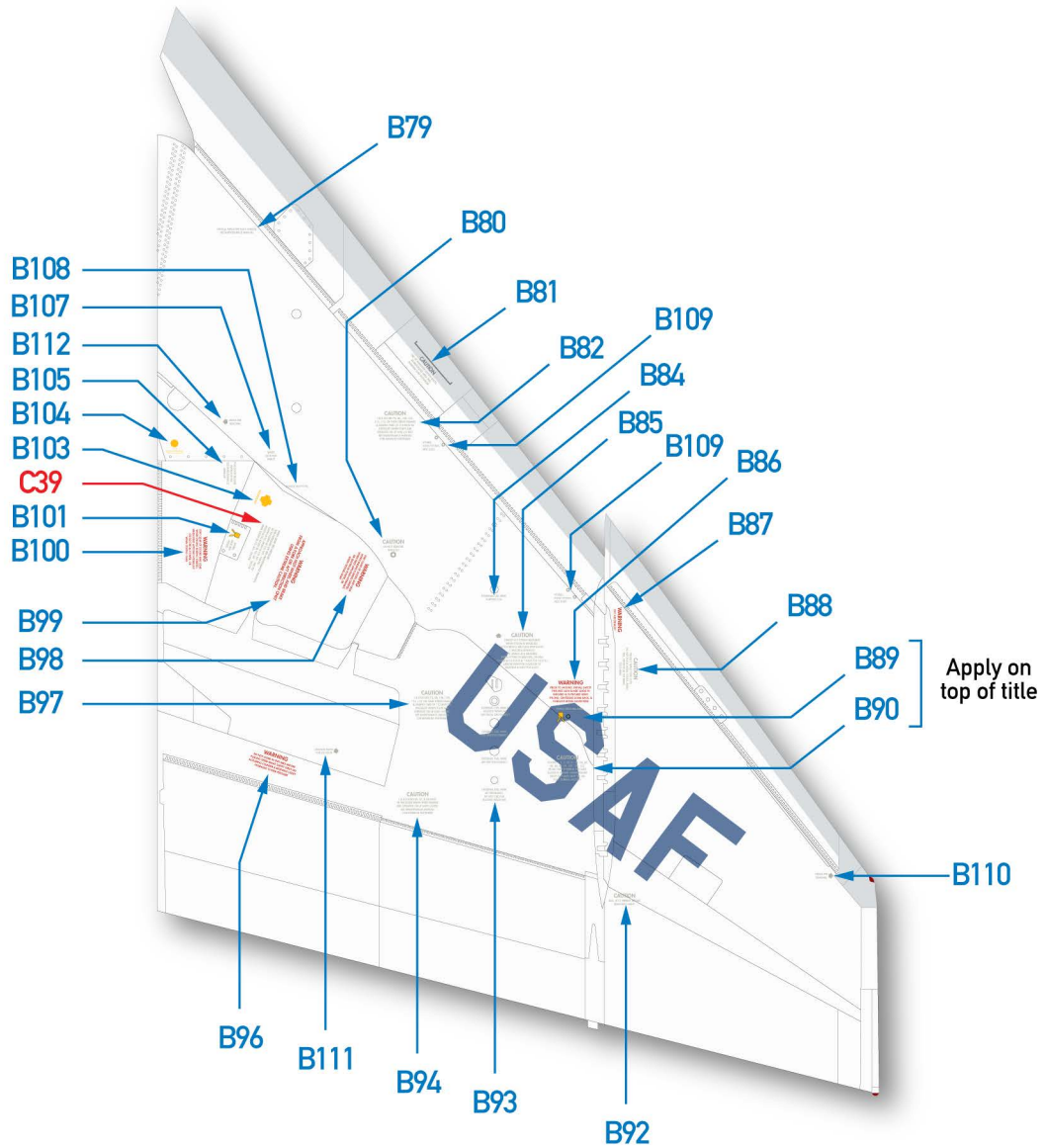

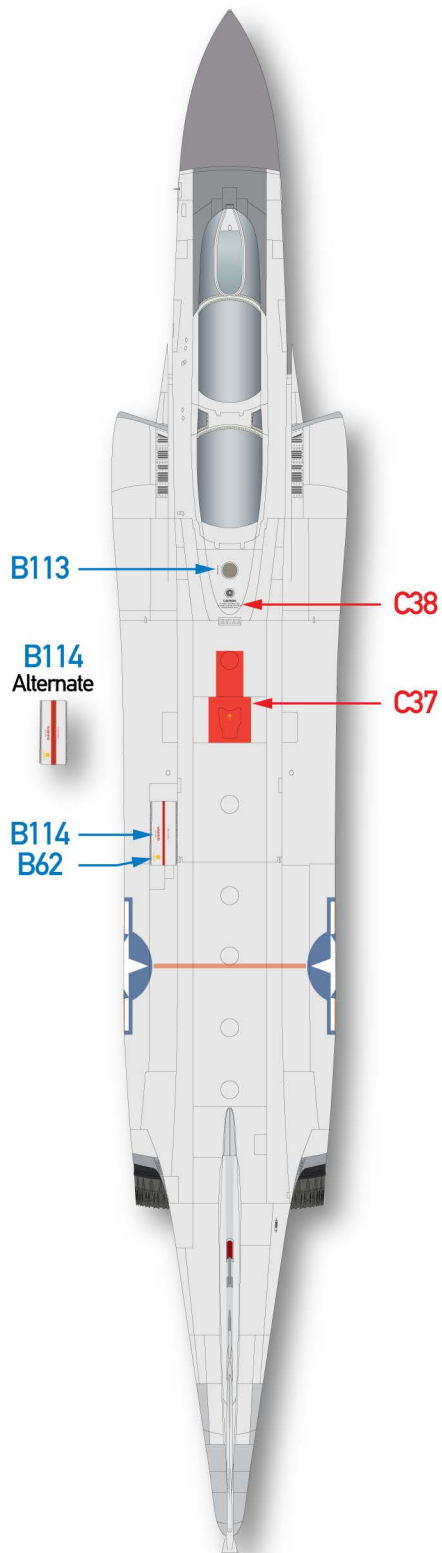

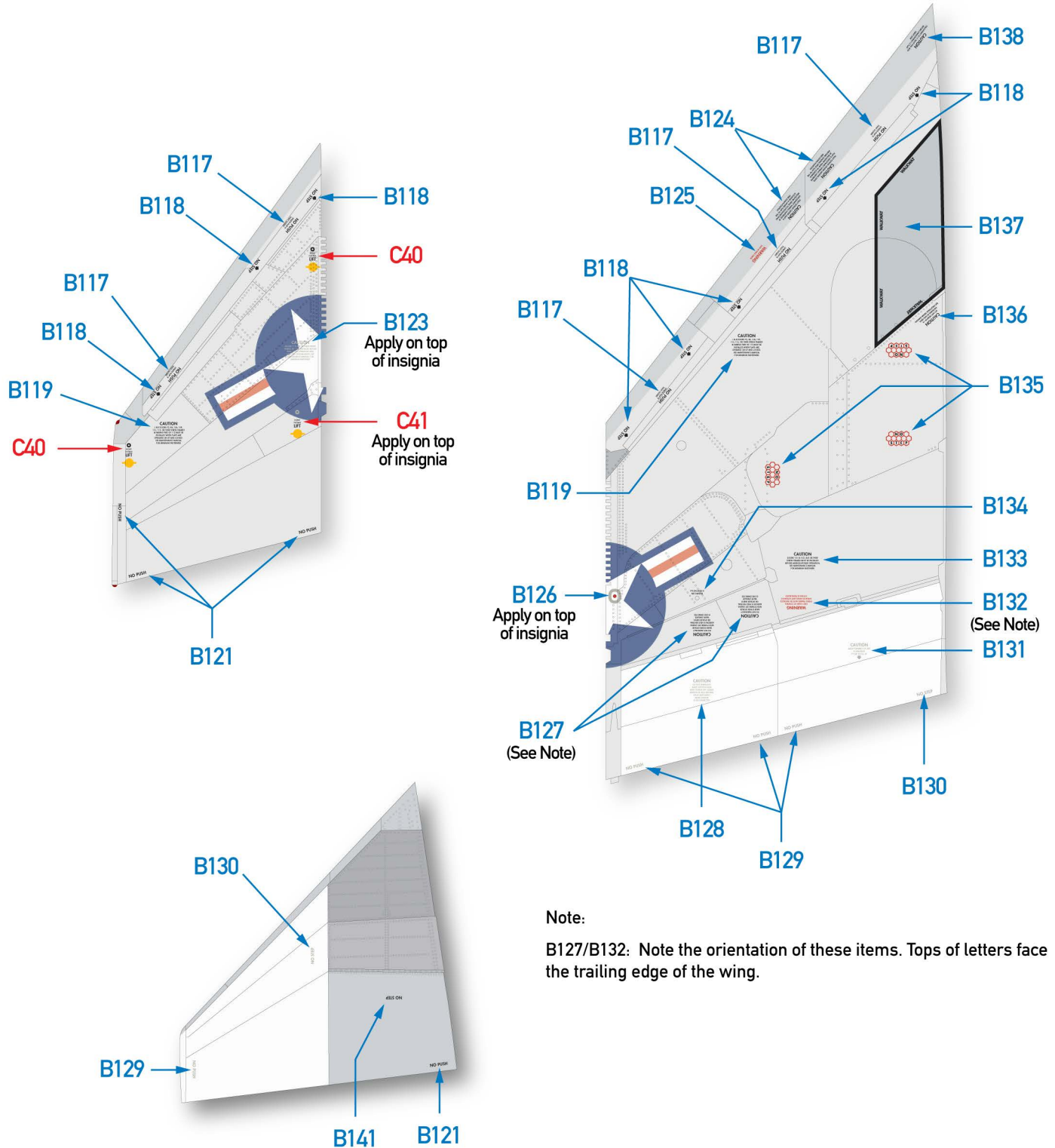

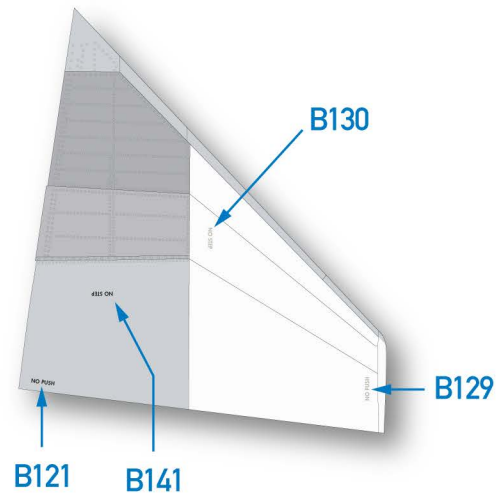
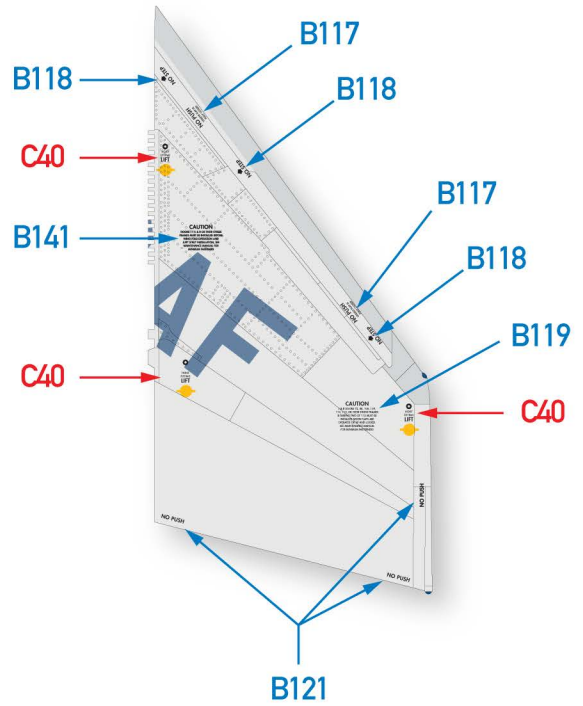
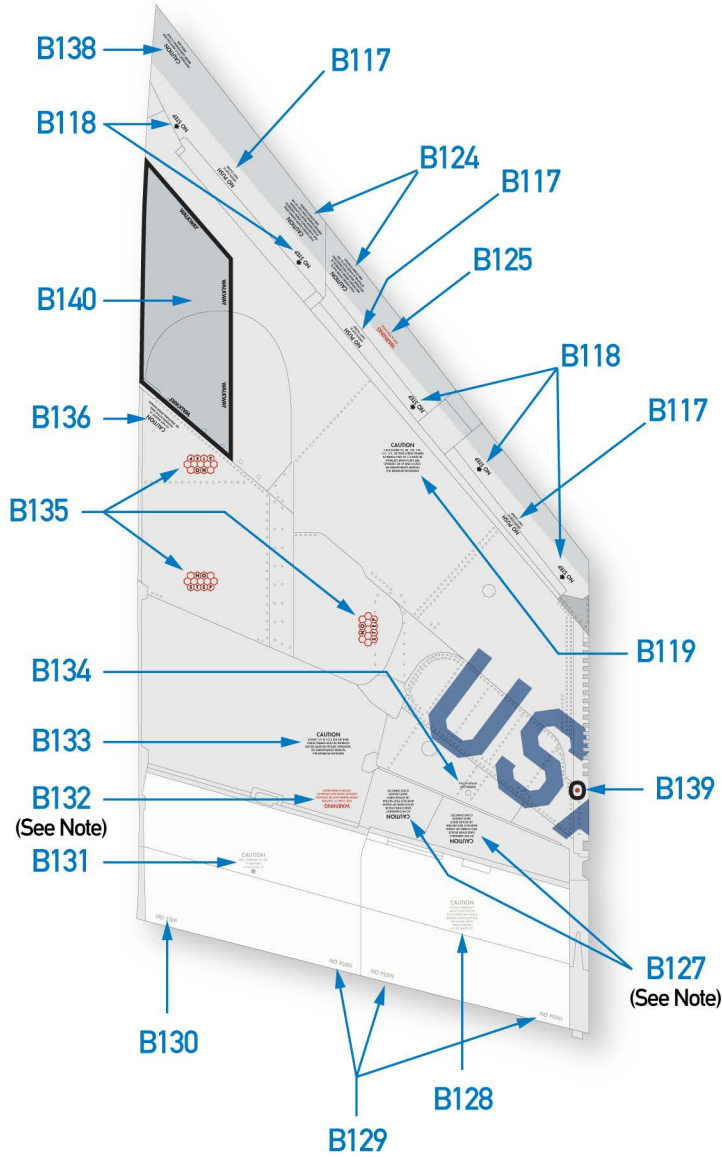

**Note:**

B127/B132: Note the orientation of these items. Tops of letters face the trailing edge of the wing.



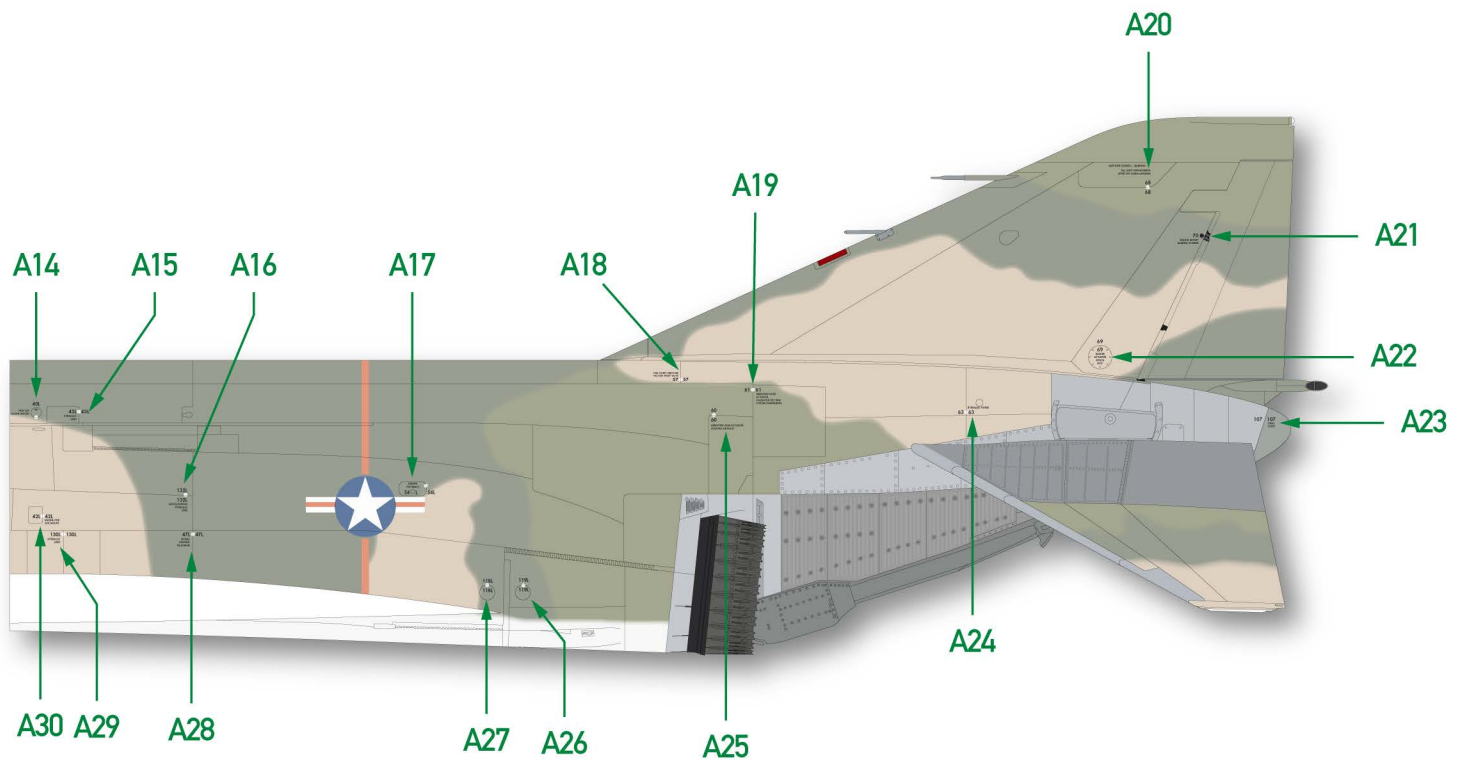
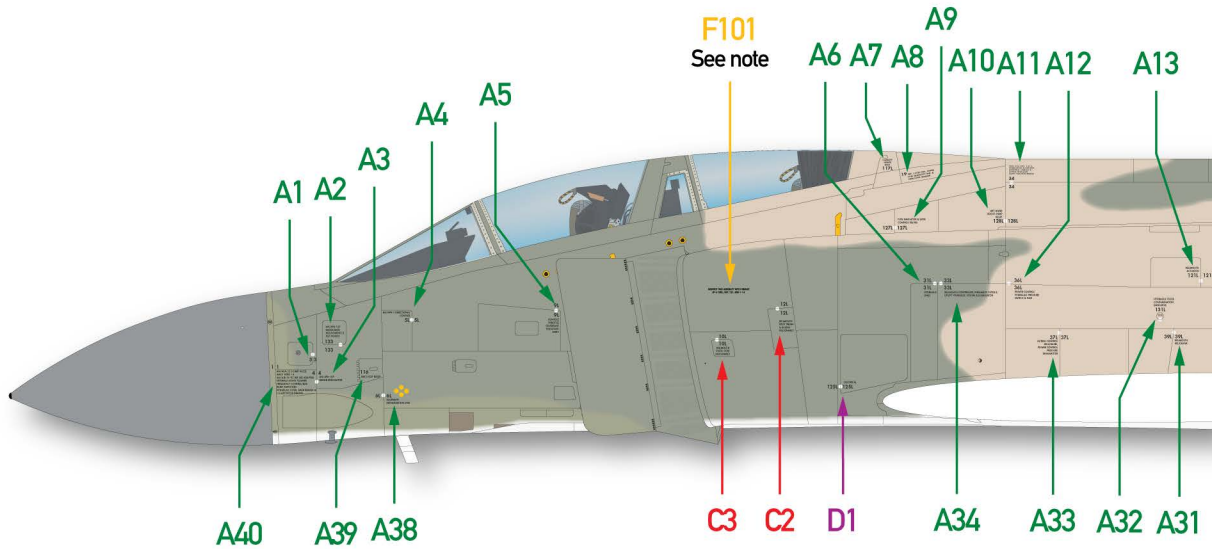

**Note:**

F101: This portion of the standard aircraft data block was applied on export aircraft (Iranian F-4Ds in this case). On USAF aircraft, there were two lines above it giving the production block number and USAF serial. Stencils applied to the Asia Minor camouflaged F-4Ds for Iran were identical to US F-4Ds.



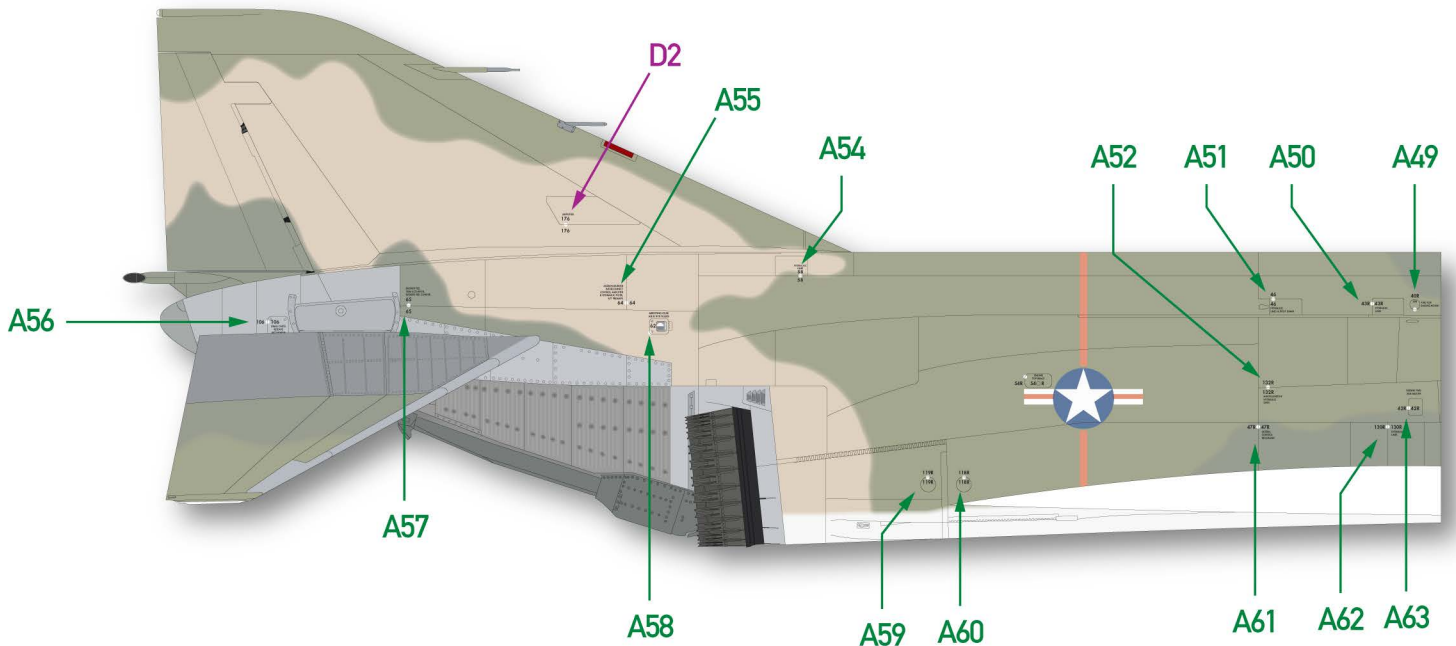
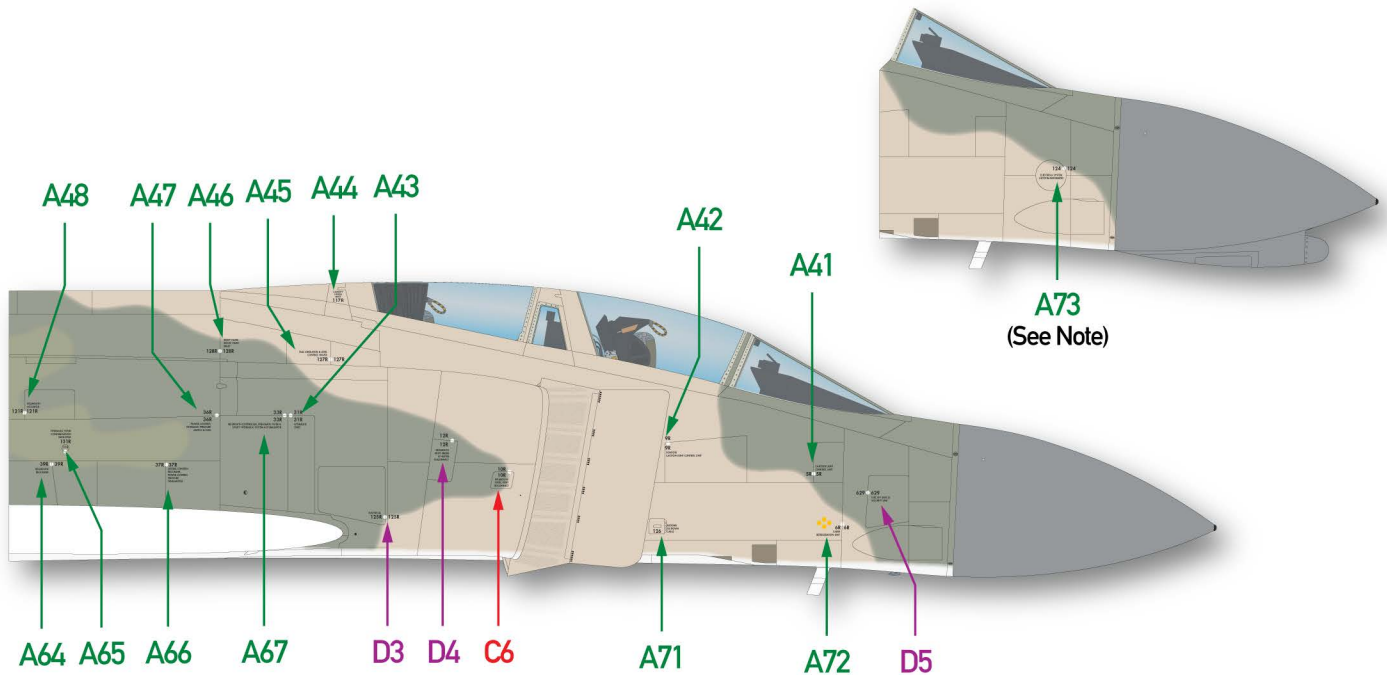

Note: The round Access Door 129 (decal A73) was seen on all F-4Cs and some early F-4Ds. When the KY-28 secure voice encryption system was installed, the trapezoidal Access Door 629 (decal D5) was installed. Earlier aircraft were updated throughout the late 1960s, but it was not seen fleet wide until well into the early 1970s.

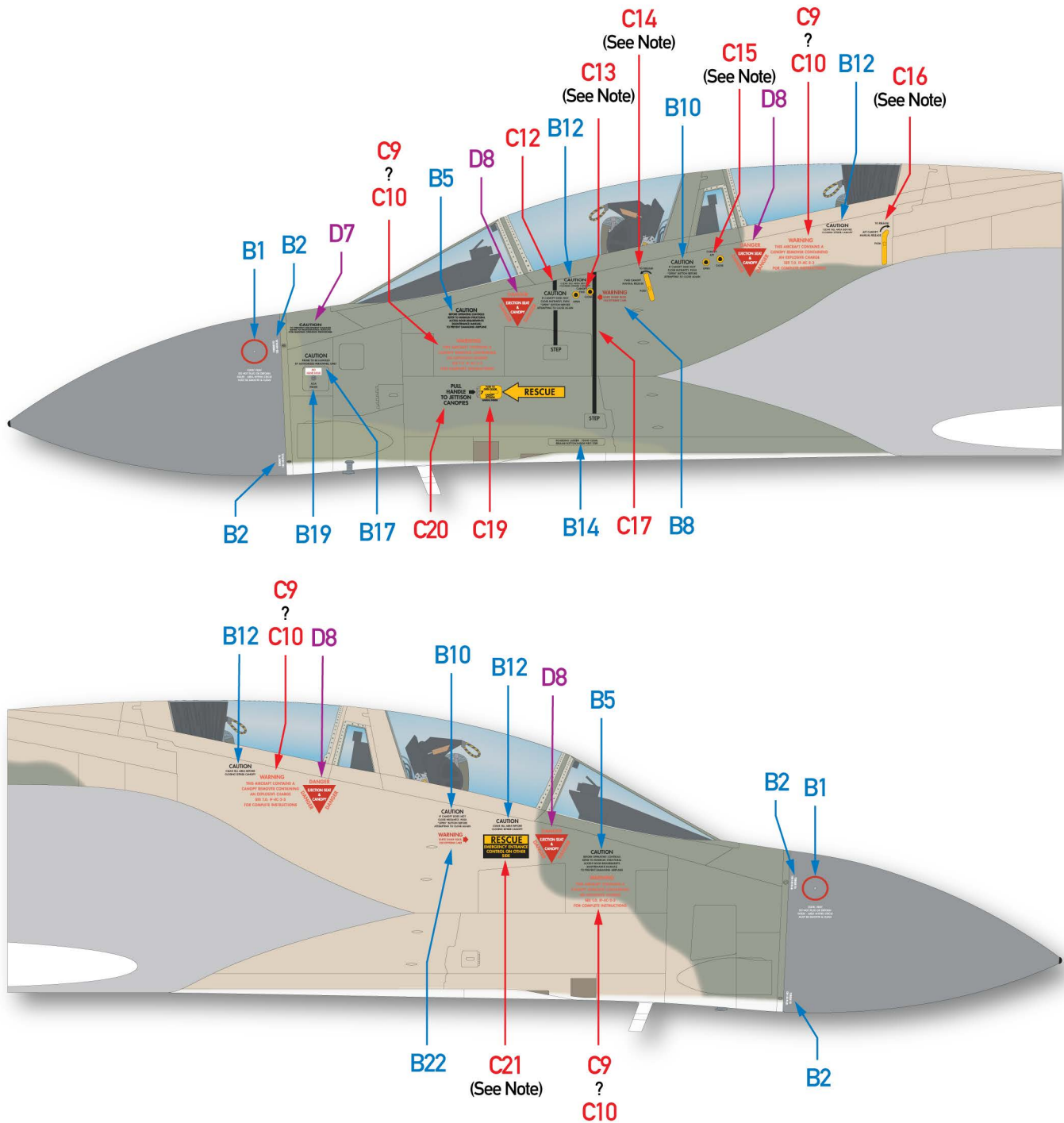

### Notes:

C9/C10: The salmon colored stencil (C9) was most commonly used, but the bright red version (C10) was also applied on some aircraft.

C13 - C16: Canopy open/close buttons & handles are provided to fit the ZM and Tamiya kit scribing (as closely as can make them), as well as in the actual scale size and shape based on tracings and measurements of these items on an actual F-4. The kit scribing (on every existing 1/48 F-4 kit we have found) is not really accurate in size or shape. We recommend filling the scribed detail and using the "B" versions of these decals, which are accurate scale representations of the real thing.

C21: Two variations are provided. The one shown in the drawing is by far the most common.

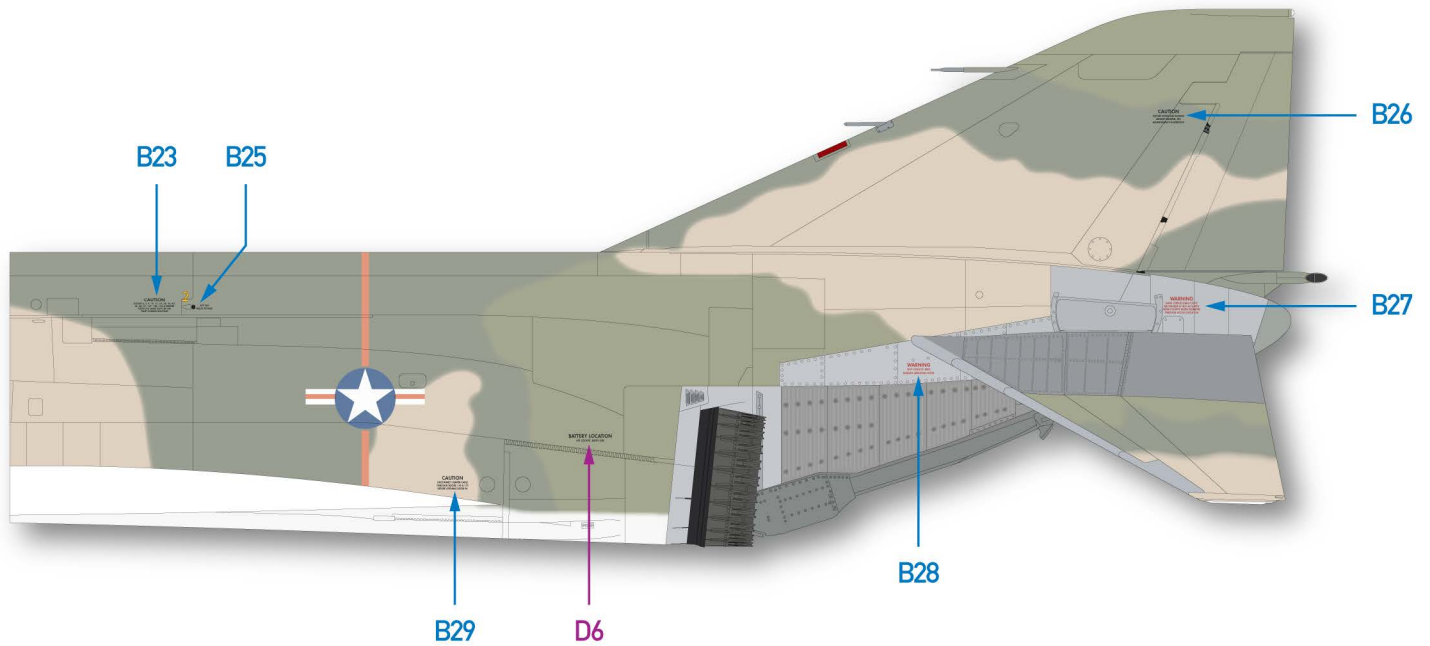
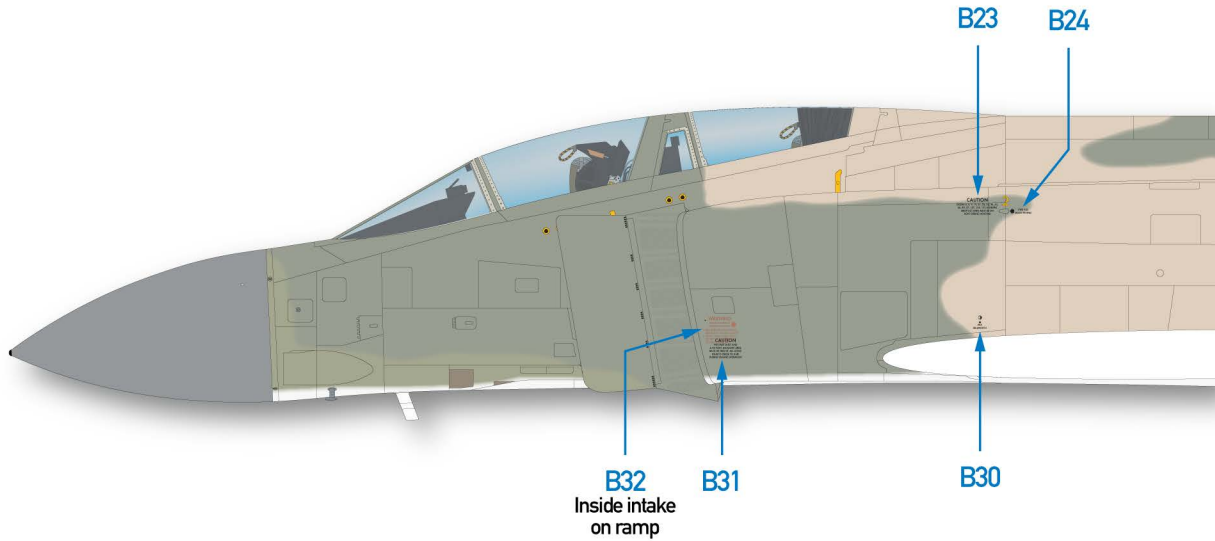

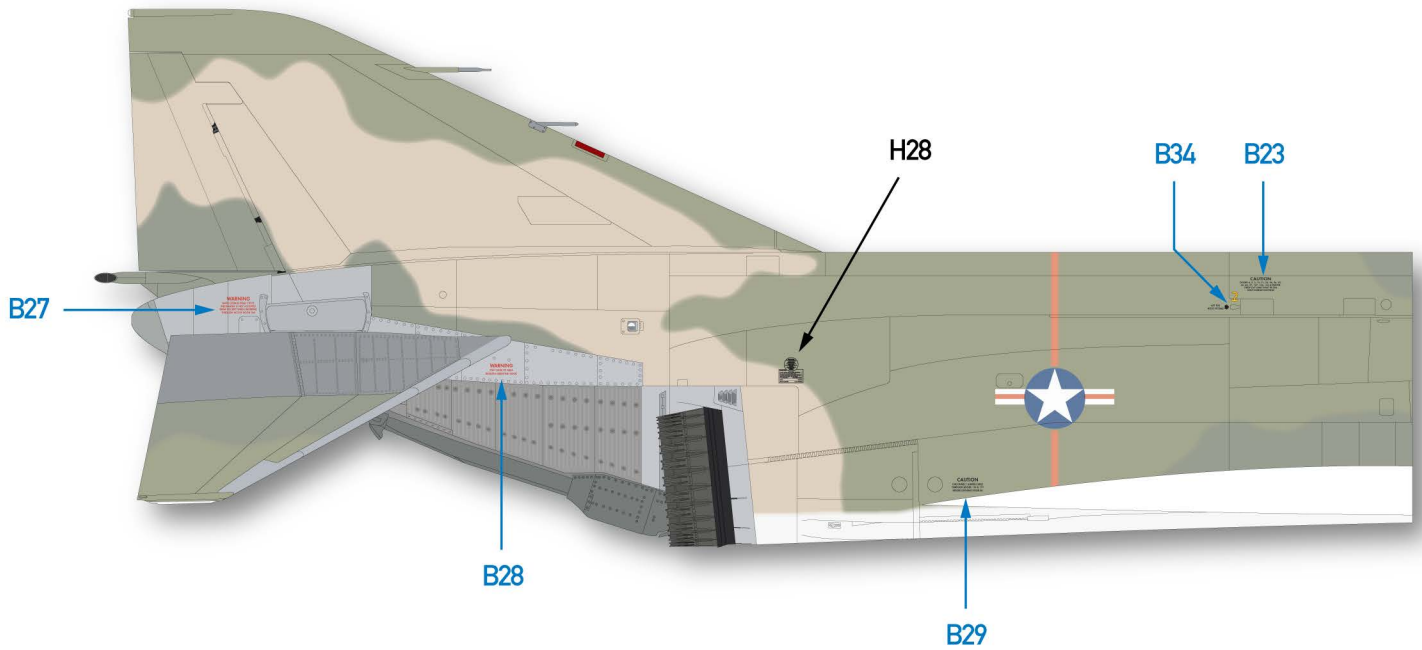
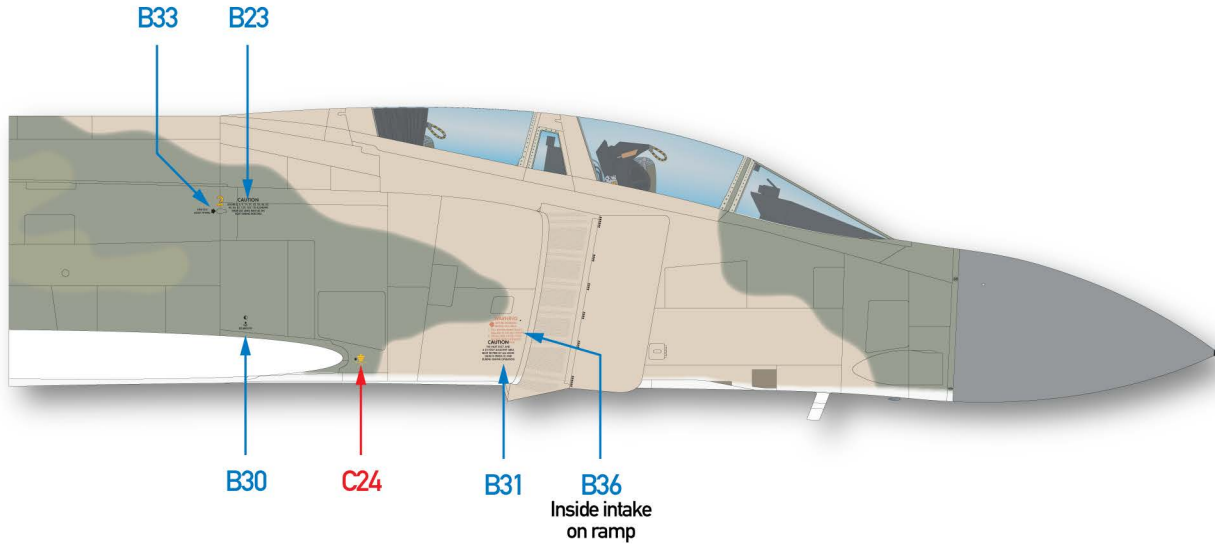

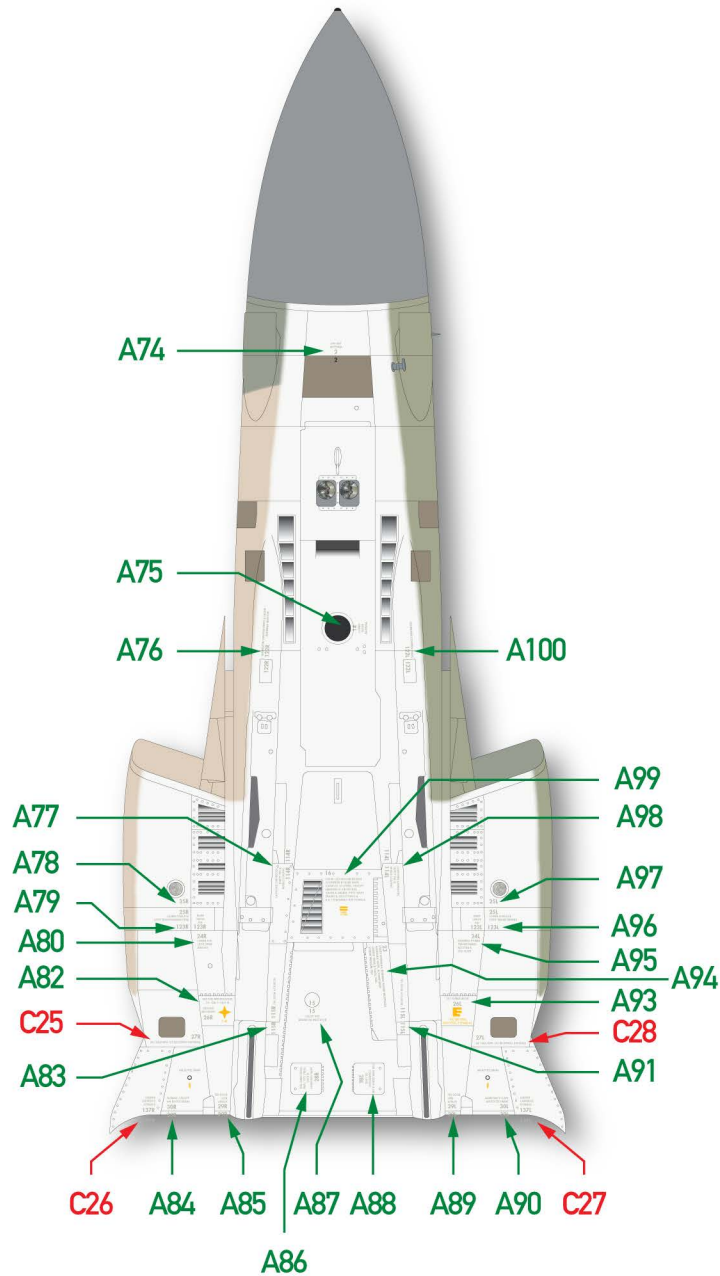



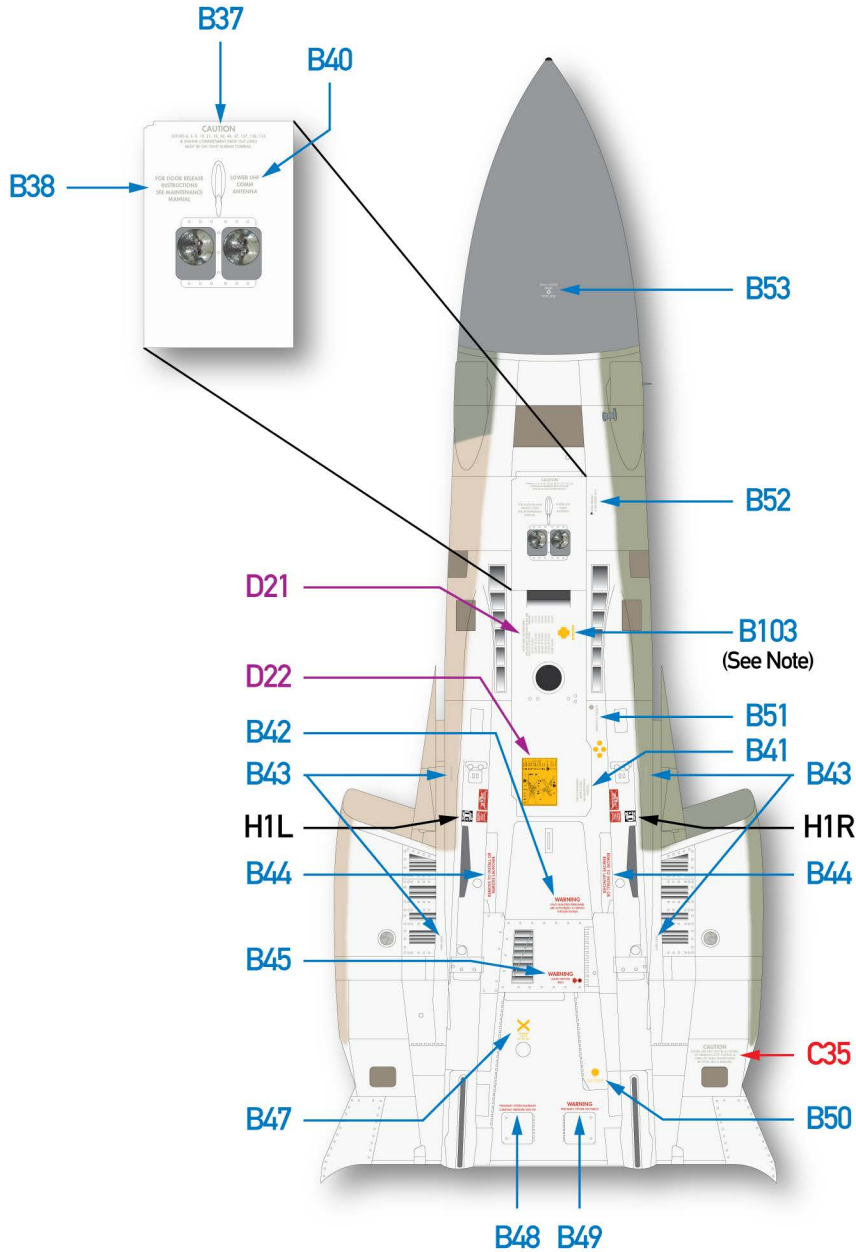

**Notes:**

Decal C34 omitted intentionally.

B103: Not applied until well into F-4D production. We do not have a specific block or serial, so check references.

↑  
Forward

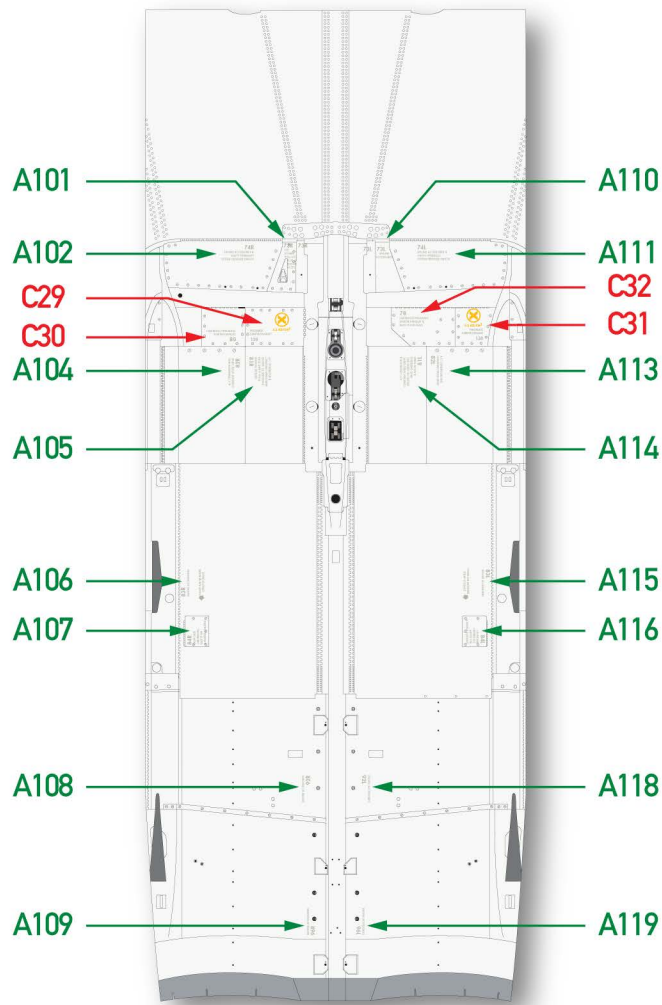

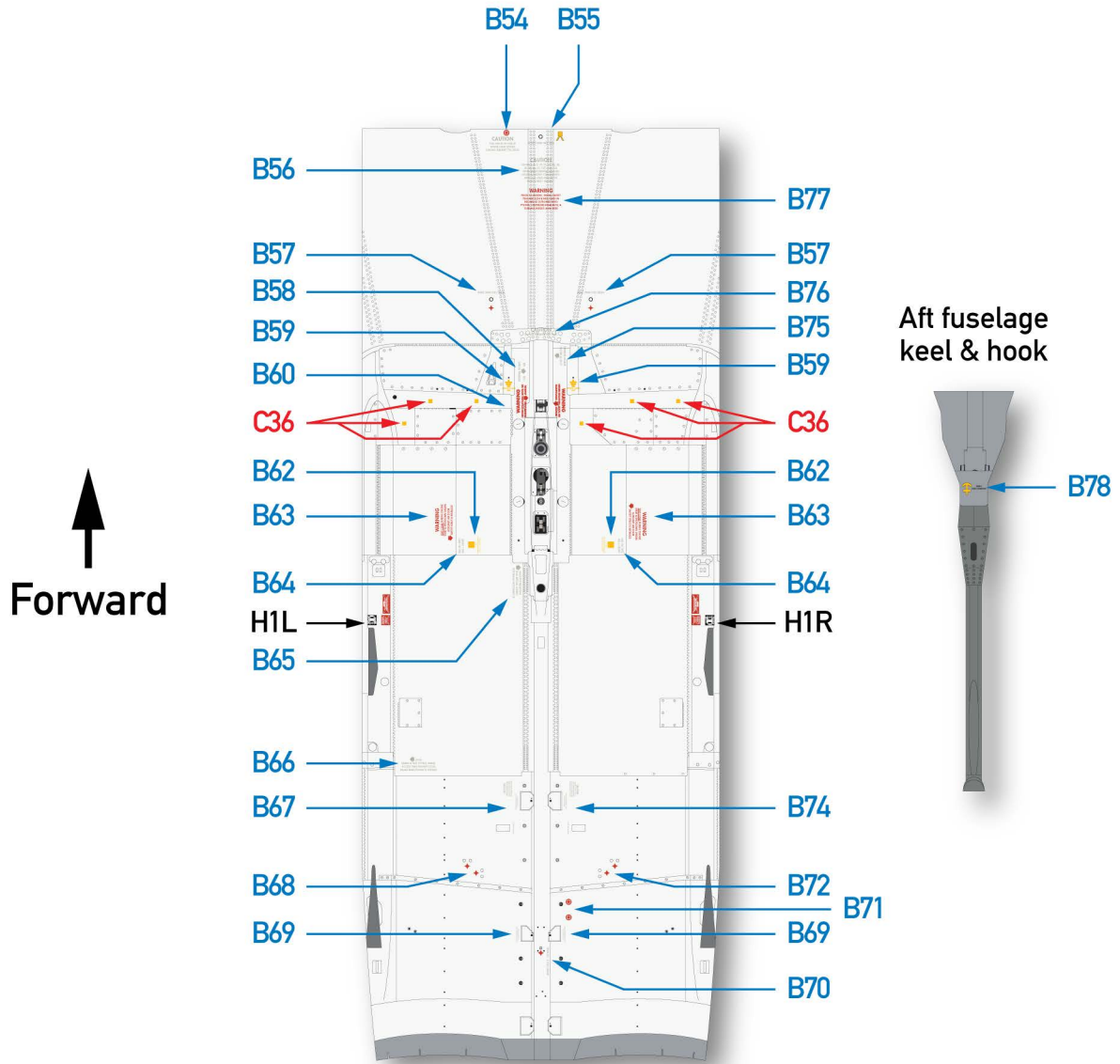

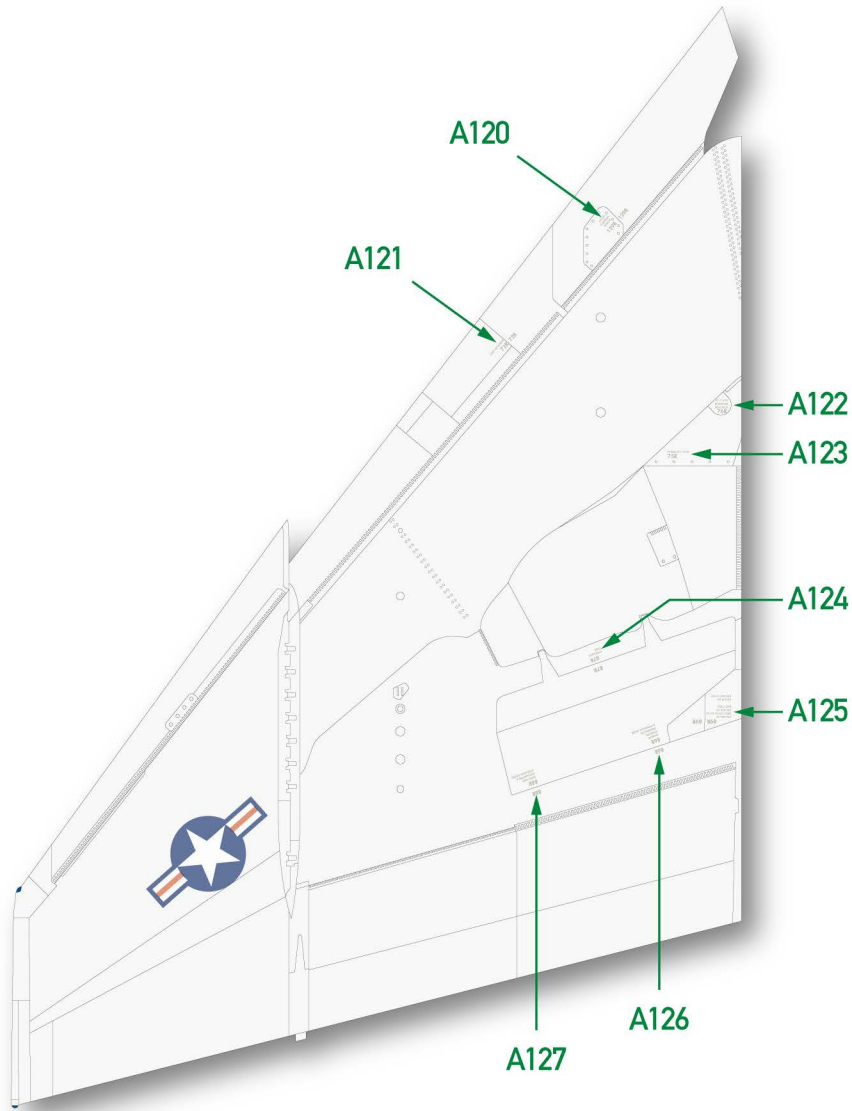

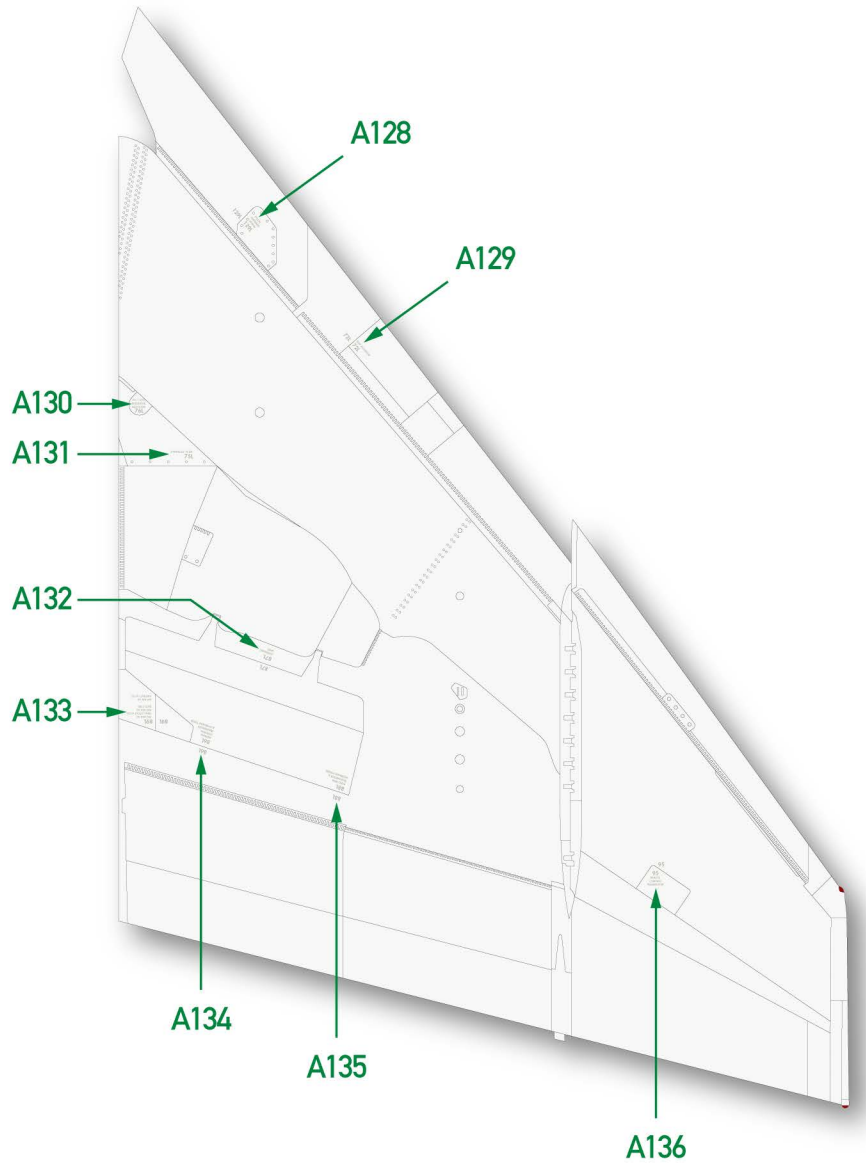



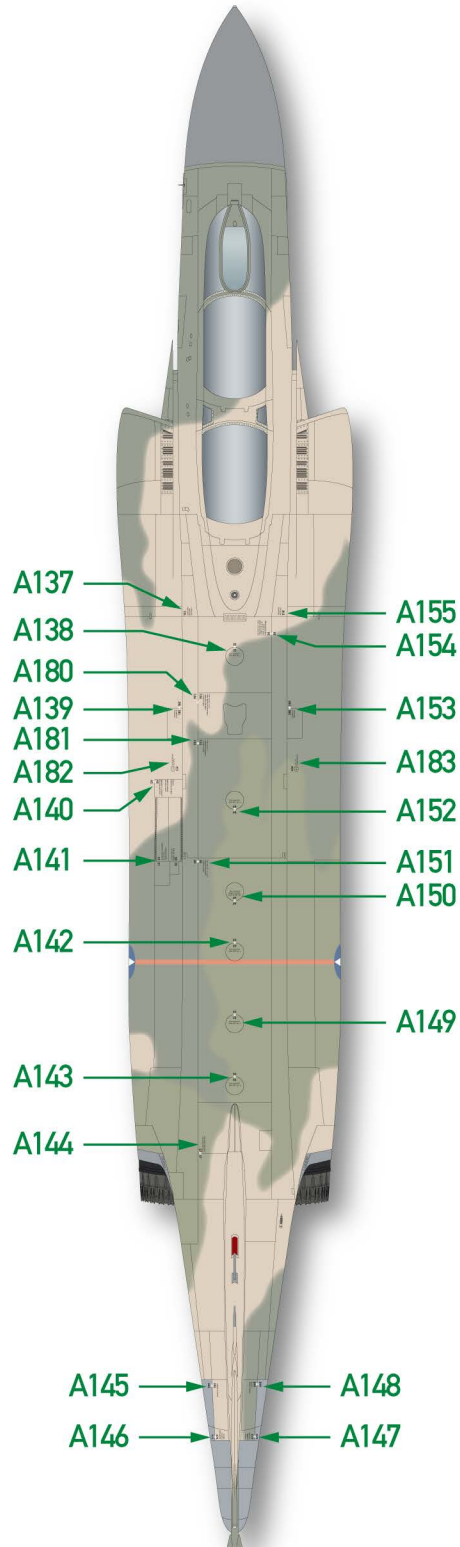

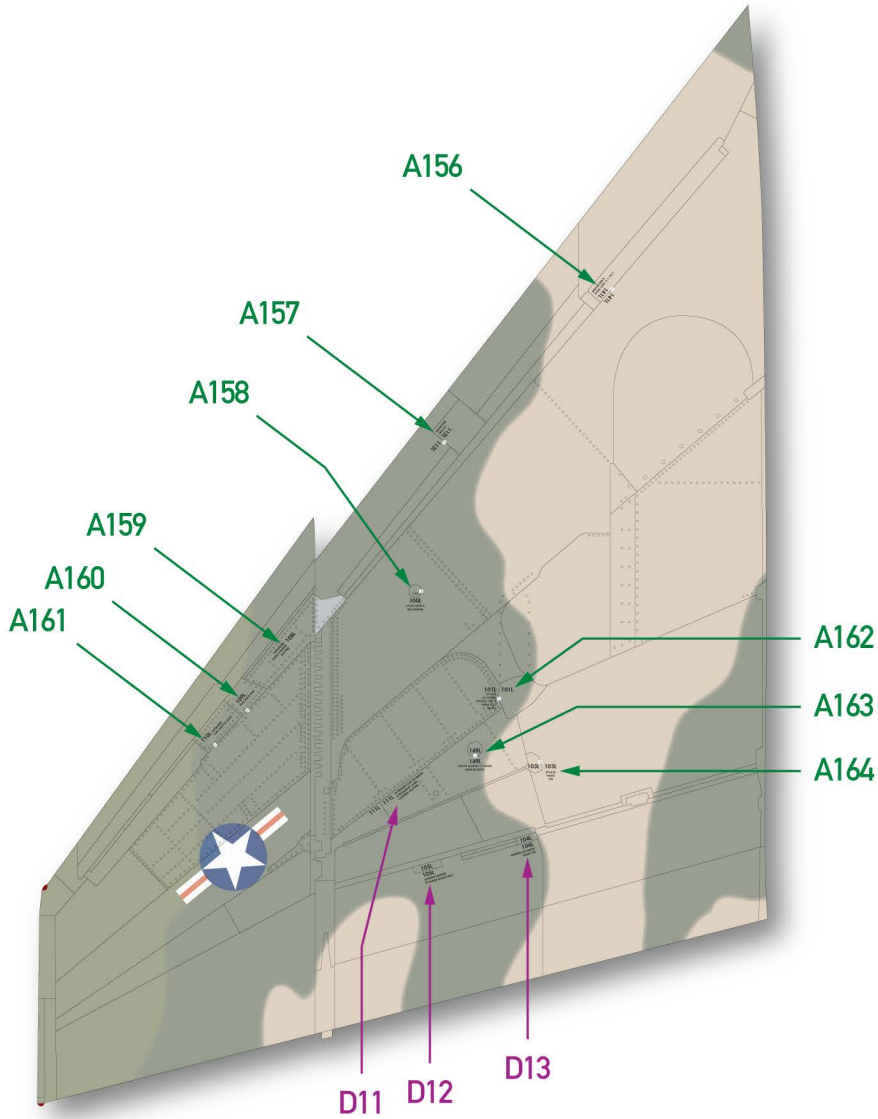

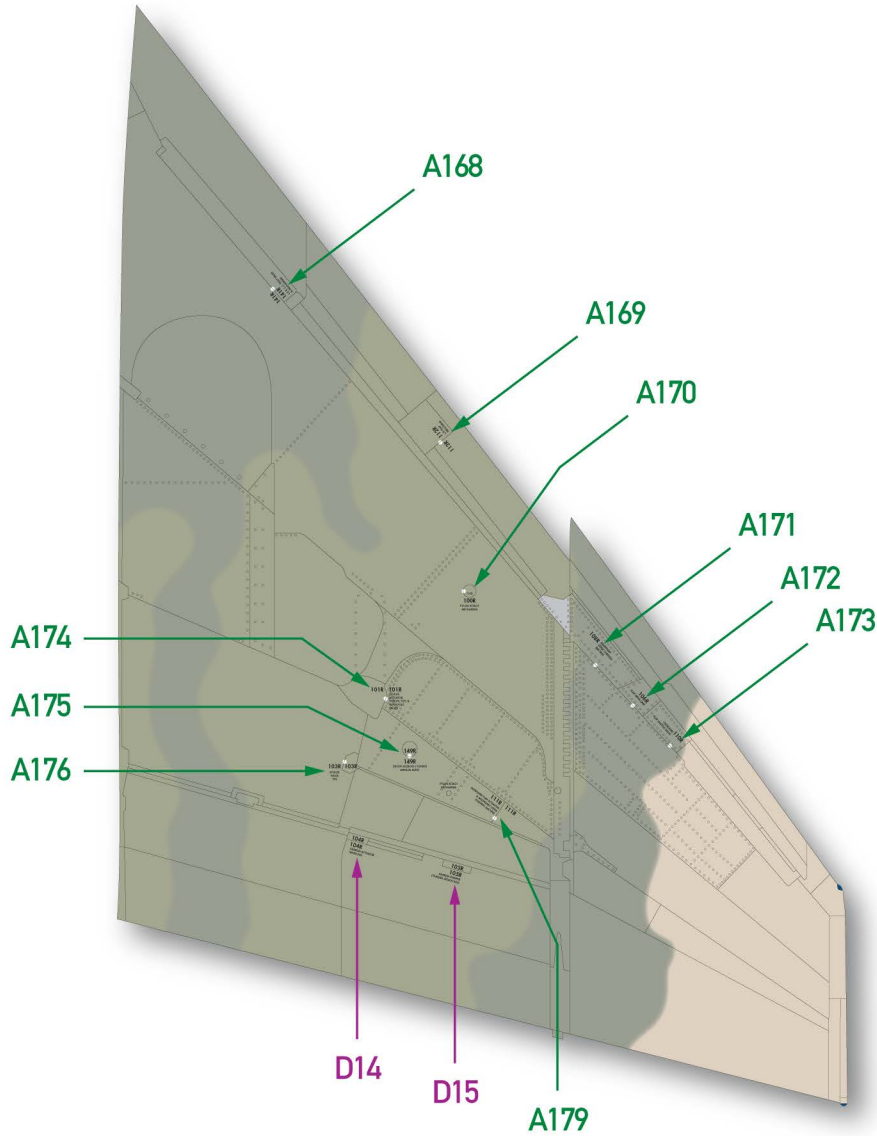

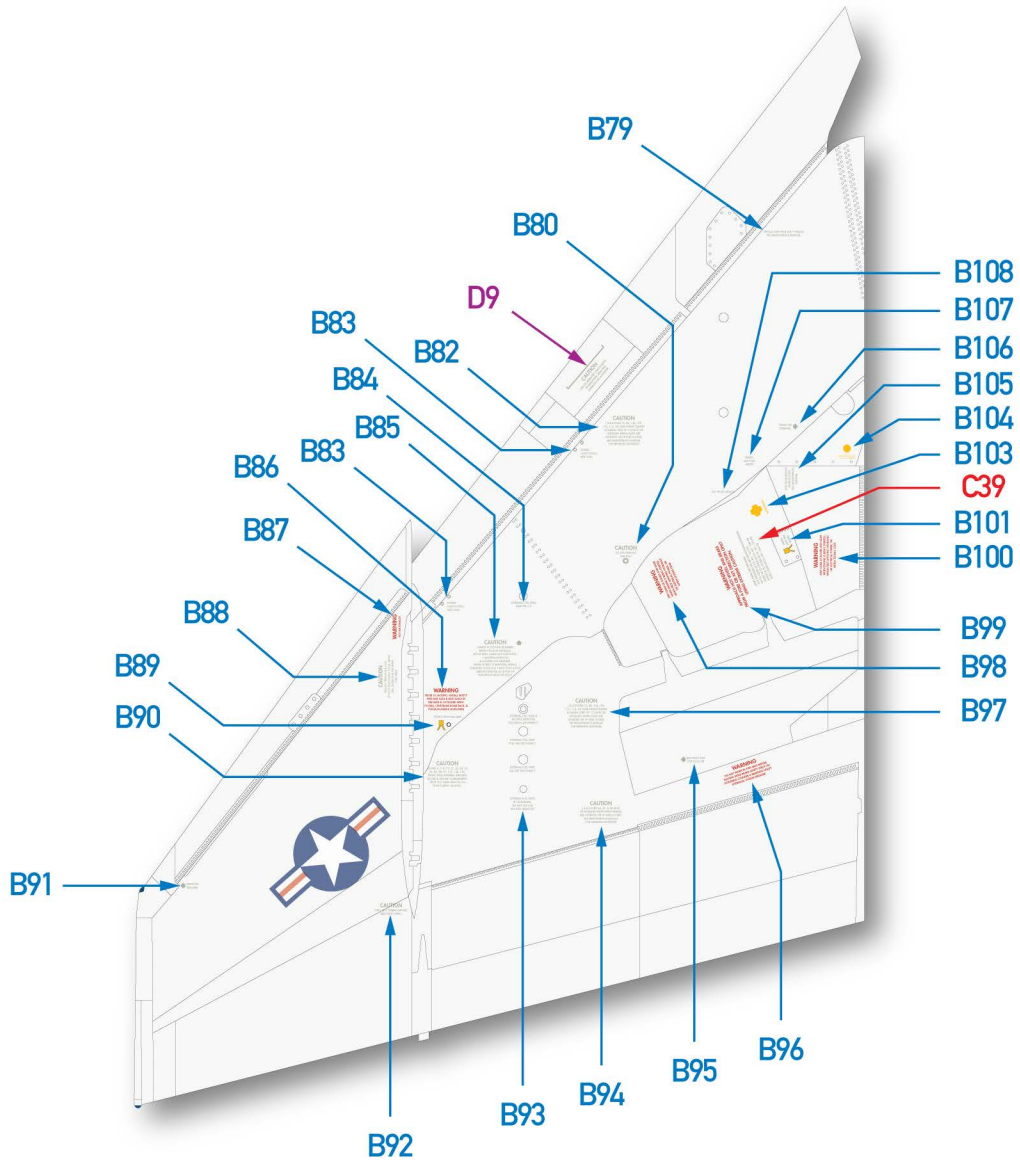

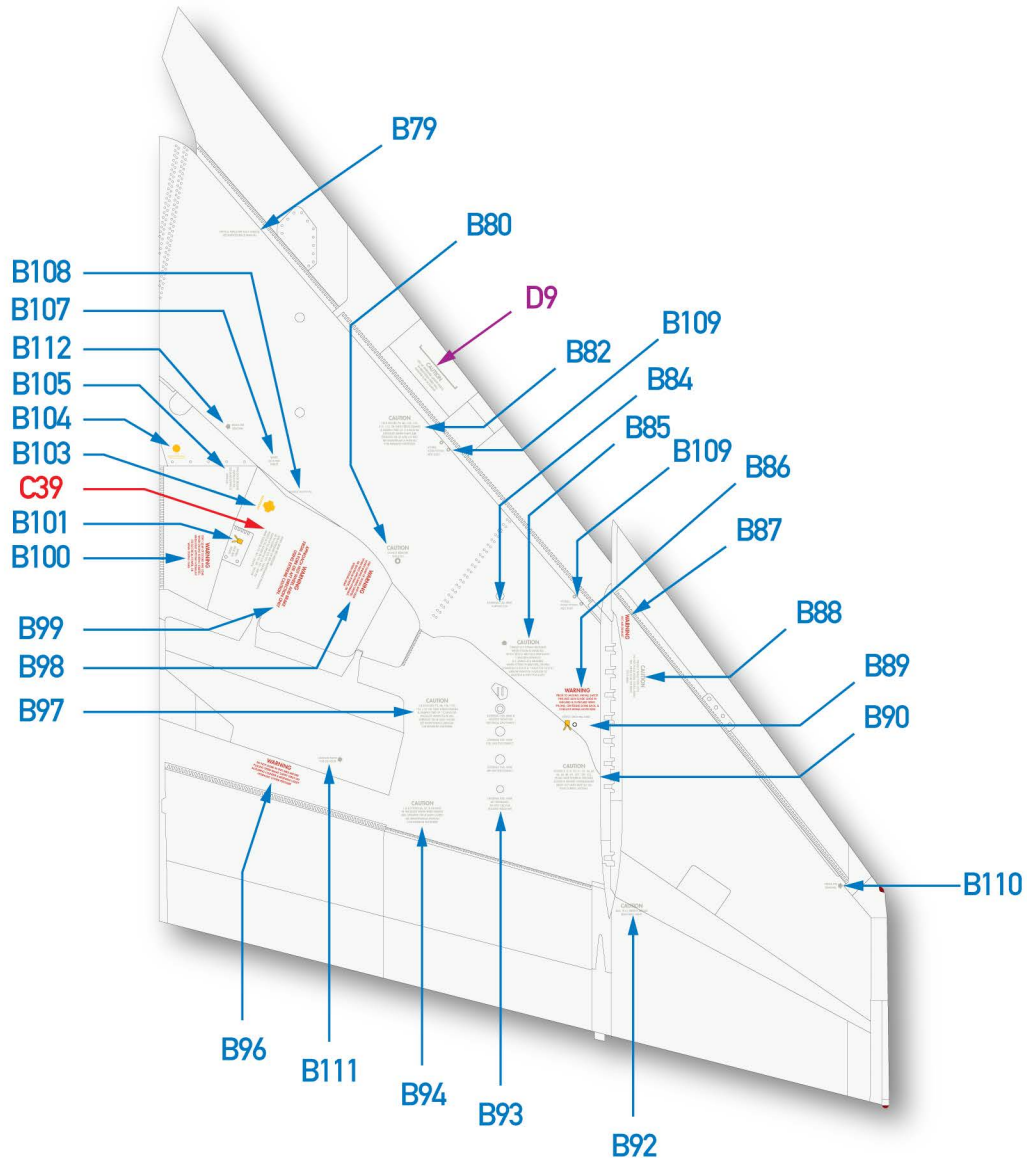



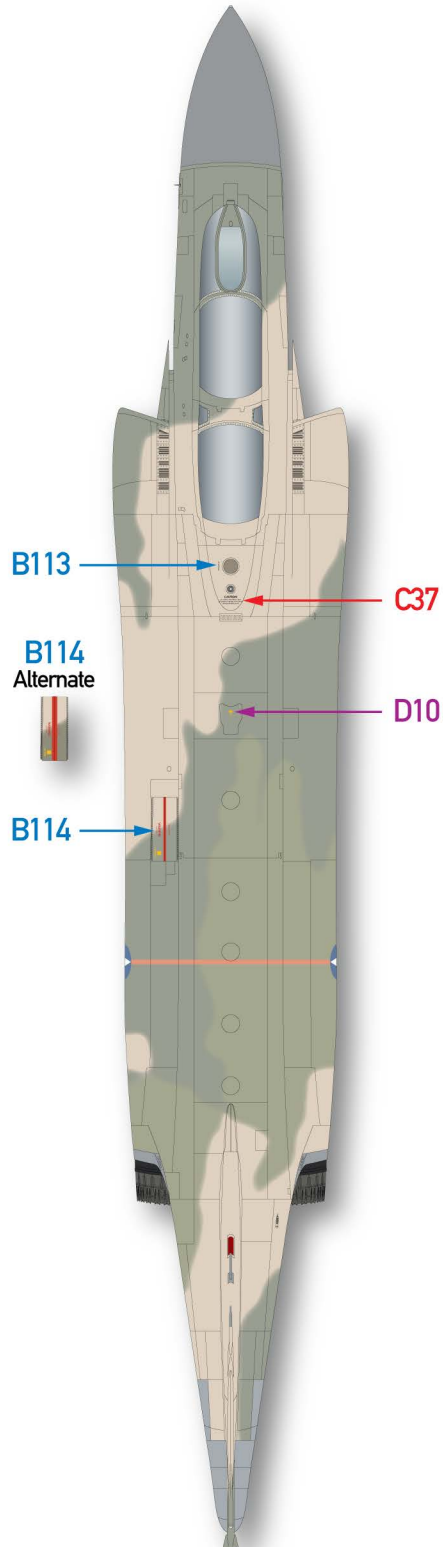

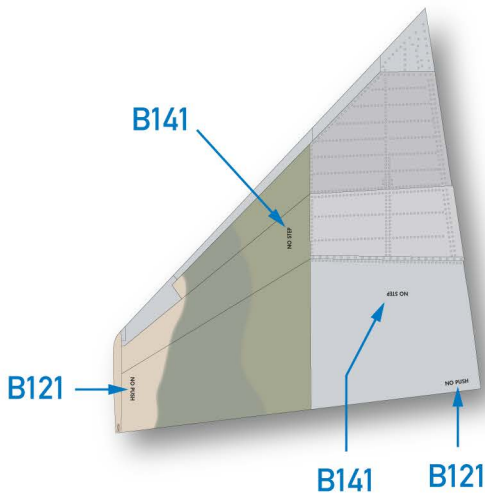
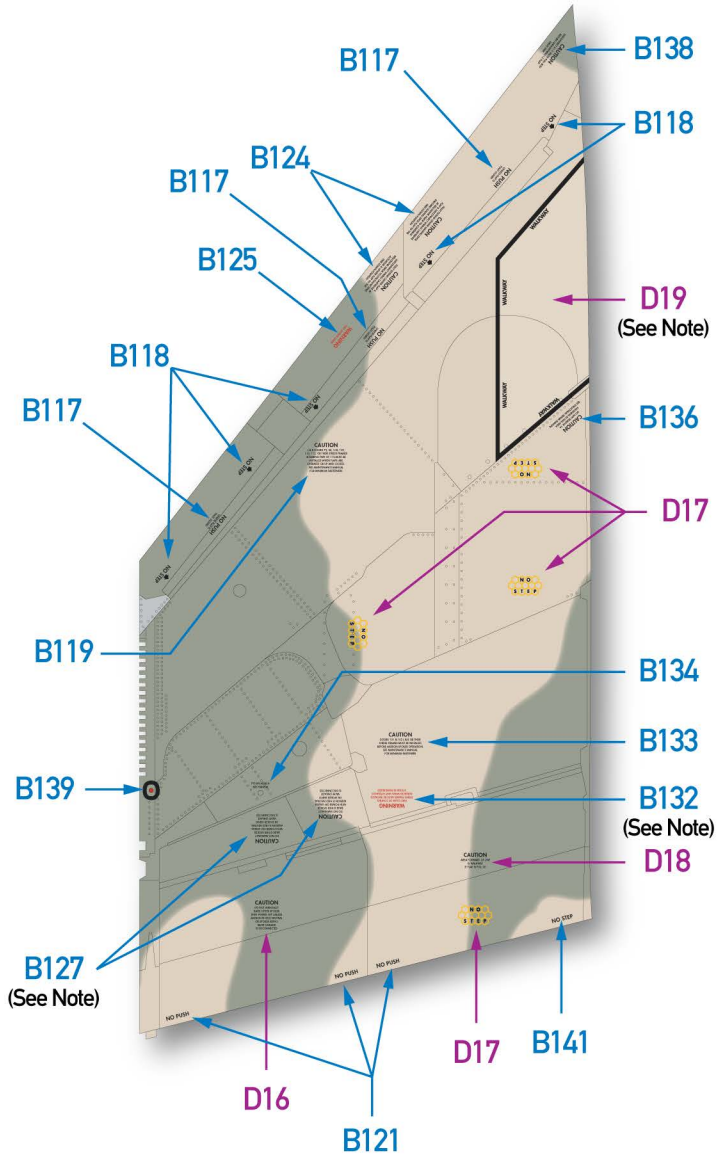
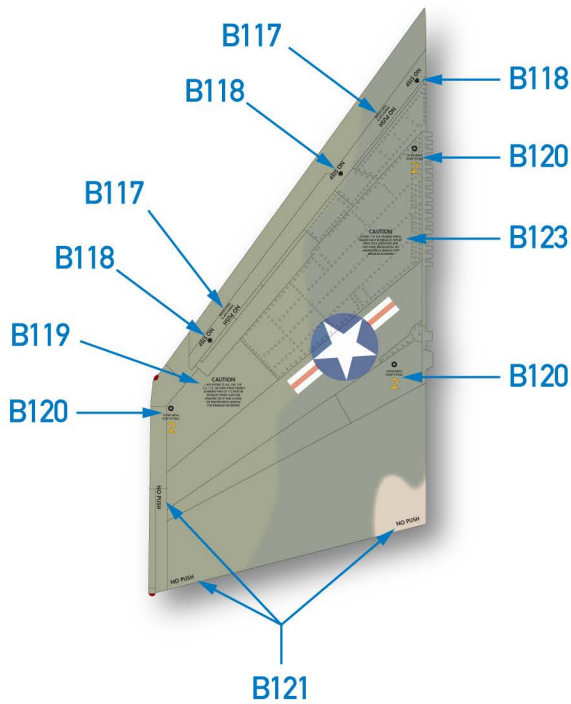

### Notes:

D19/D20: When applied at the factory, the area inside the walkway outline was finished with tinted Corogard paint. In the few photos we have where you can clearly see this area on a factory finished aircraft, the left hand (tan) Corogard area appears to be slightly lighter in tone than the surrounding camouflage color, while the right hand one (green) appears darker. Of course it quickly became dirty with grime and boot marks.

B127/B132: Note the orientation of these items. Tops of letters face the trailing edge of the wing.

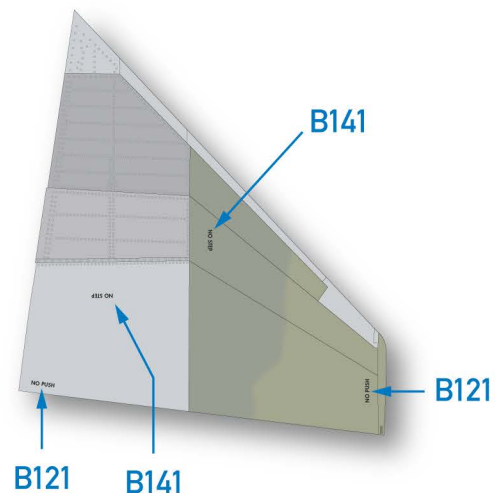
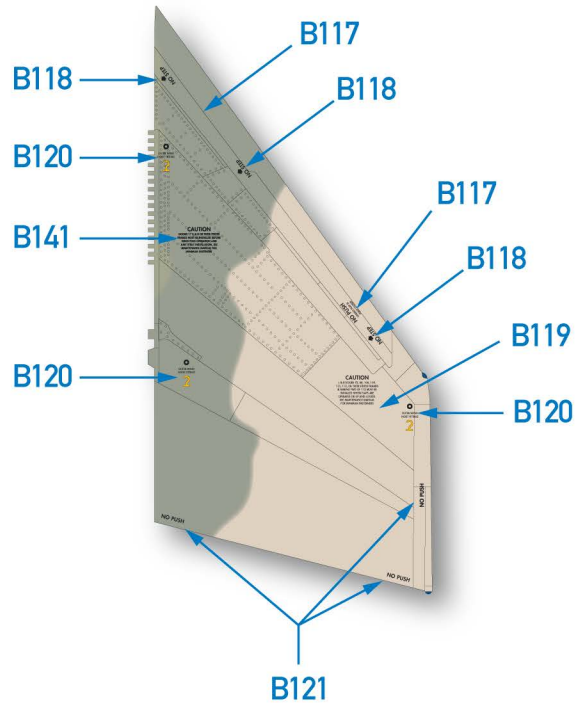
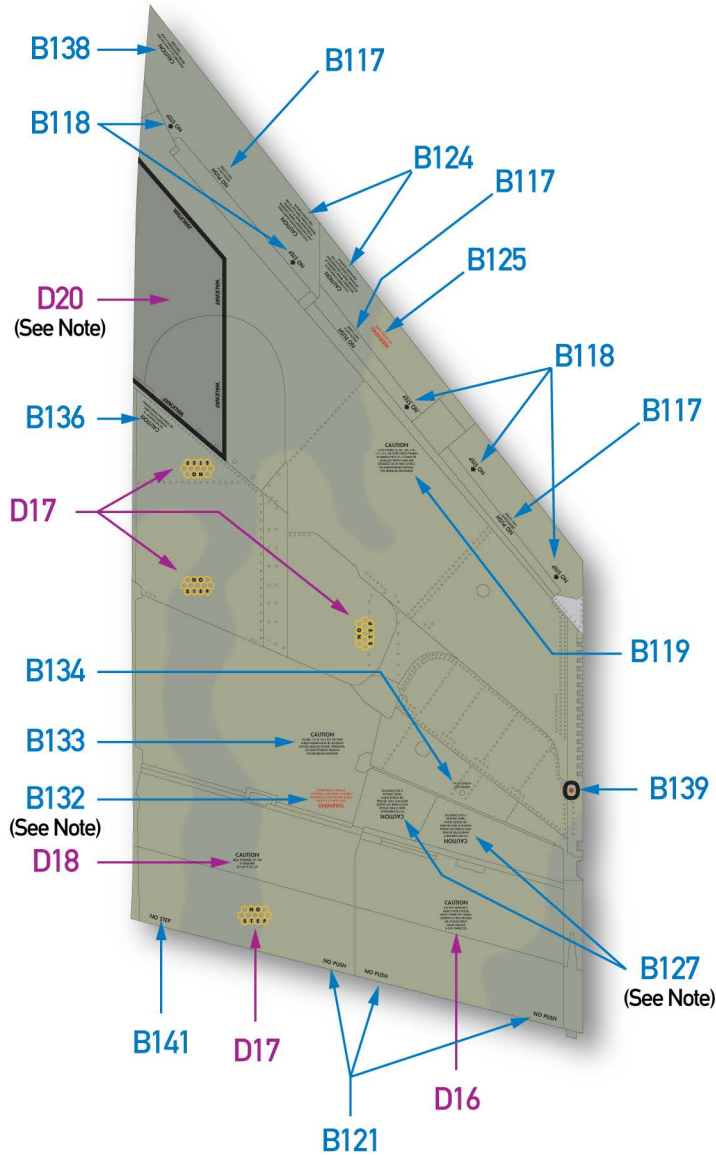

**Notes:**

D19/D20: When applied at the factory, the area inside the walkway outline was finished with tinted Corogard paint. In the few photos we have where you can clearly see this area on a factory finished aircraft, the left hand (tan) Corogard area appears to be slightly lighter in tone than the surrounding camouflage color, while the right hand one (green) appears darker. Of course it quickly became dirty with grime and boot marks.

B127/B132: Note the orientation of these items. Tops of letters face the trailing edge of the wing.