

Note: Decals H28 and H29 were not always applied. H28 is for aircraft built by McDonnell, while H29 is for aircraft built by McDonnell Douglas after the 1967 merger.

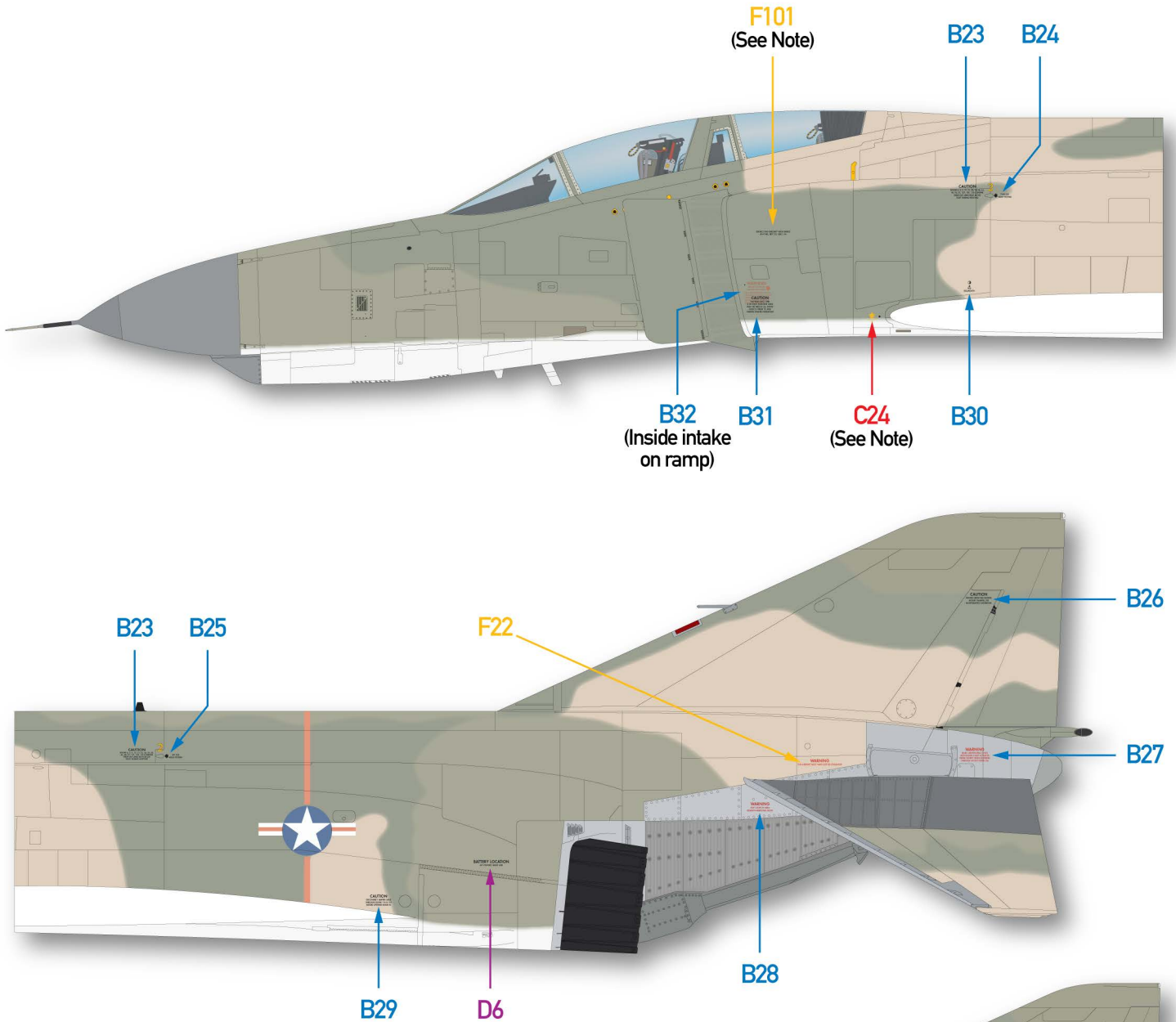

Notes:

C24: This was not applied to early F-4Es (which lacked the grounding plug in this position). It was applied to later block aircraft, but we have been unable to determine precisely when it was first installed on the production line, but to date, the earliest serial we can positively identify it on is F-4E-48-MC 71-0234.

F23A/B: Applied to F-4E-37-MC 67-0342 and subsequent. The configuration shown was most common, although the version with the red arrow touching the white rectangle was seen sporadically as well.

F101: This portion of the data block was applied to all aircraft, even on exports where the two larger lines of type (ex. U.S. AIR FORCE F-4E-39-MC, A.F. SERIAL 68-426A) were not applied.

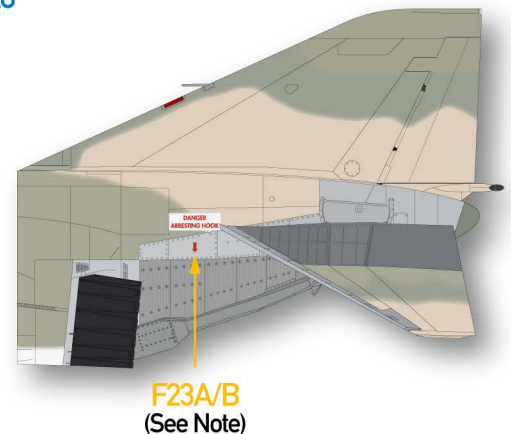

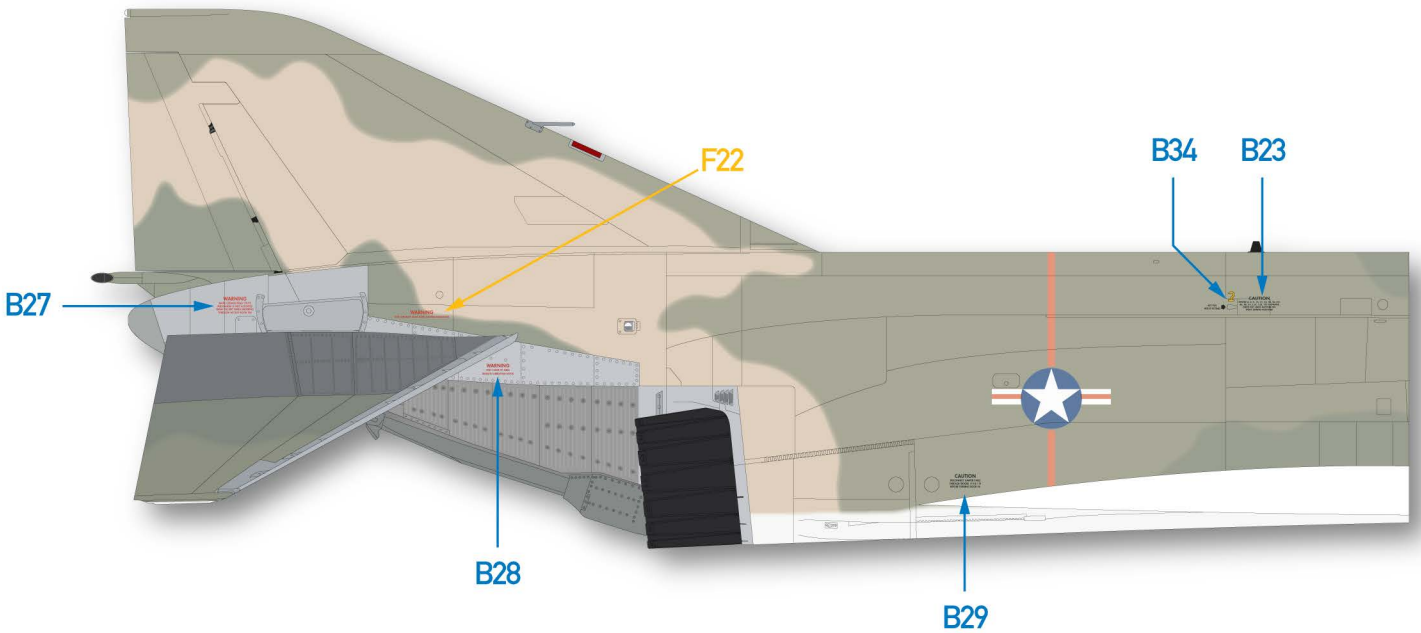
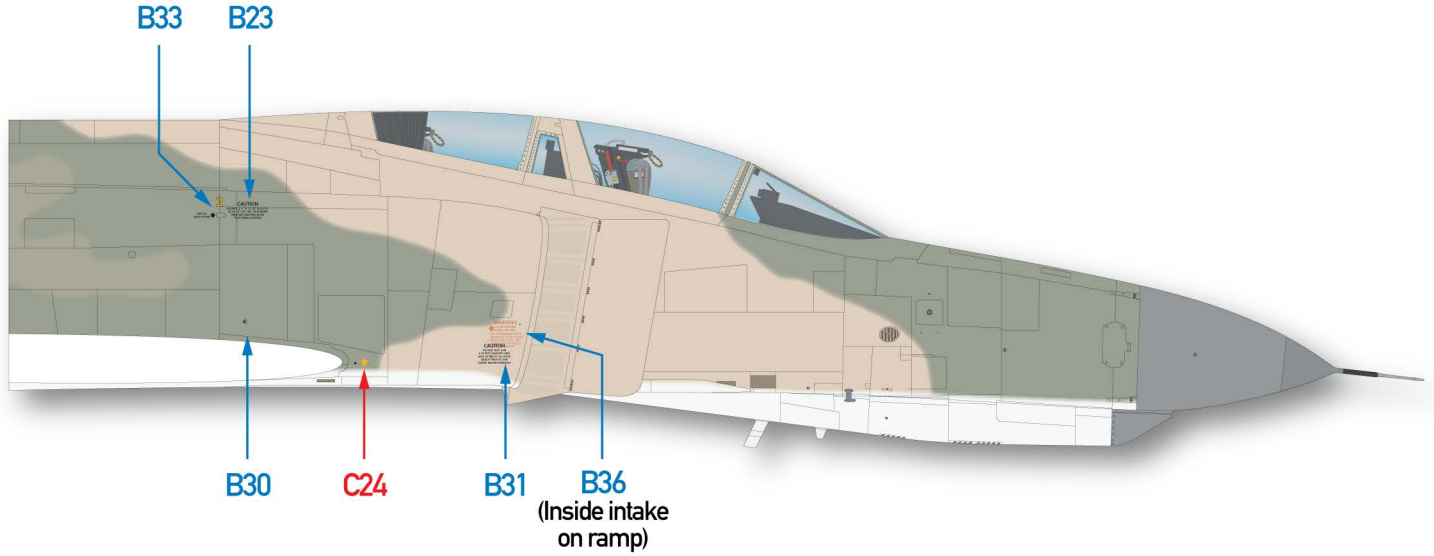

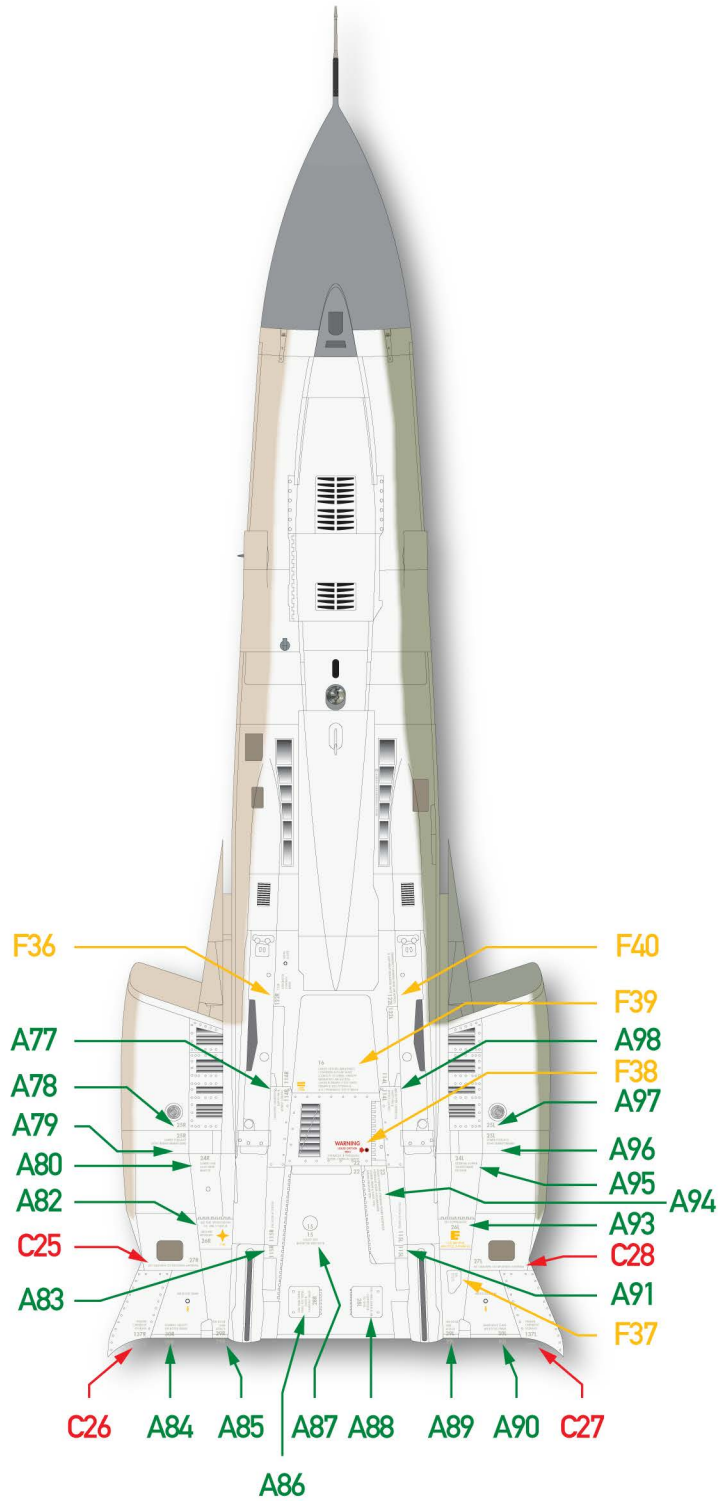

↑
Forward

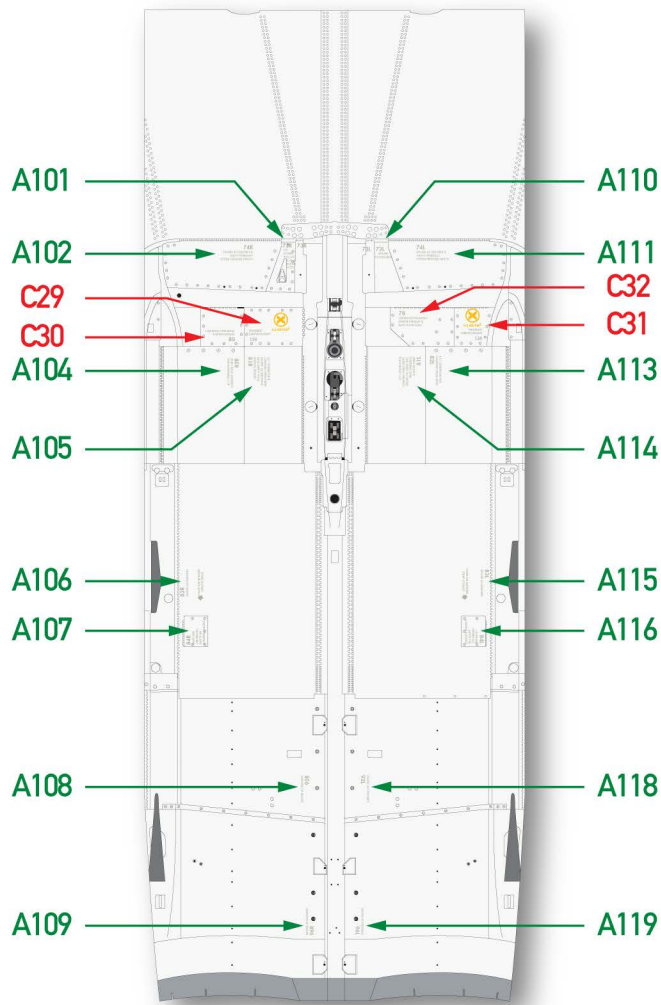

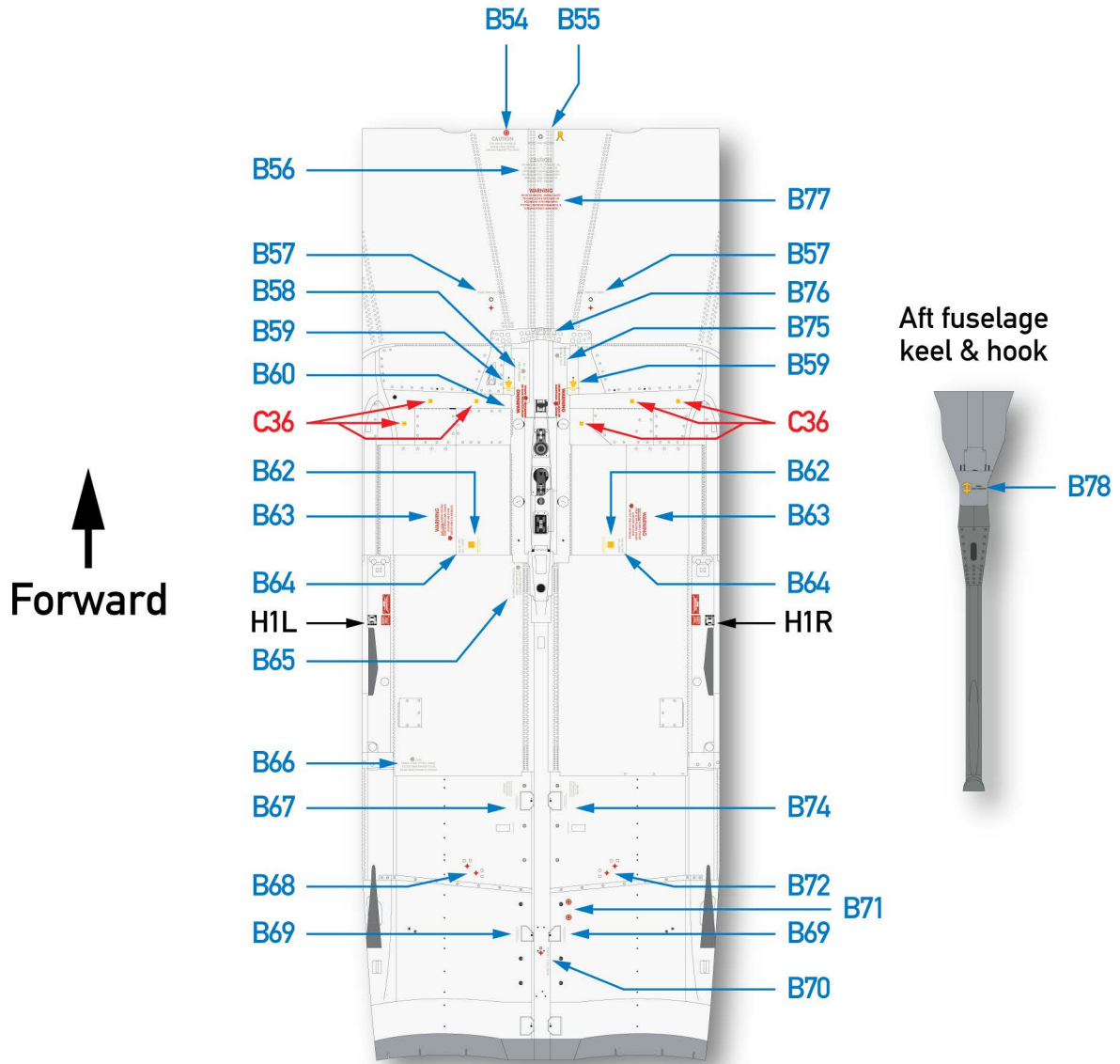

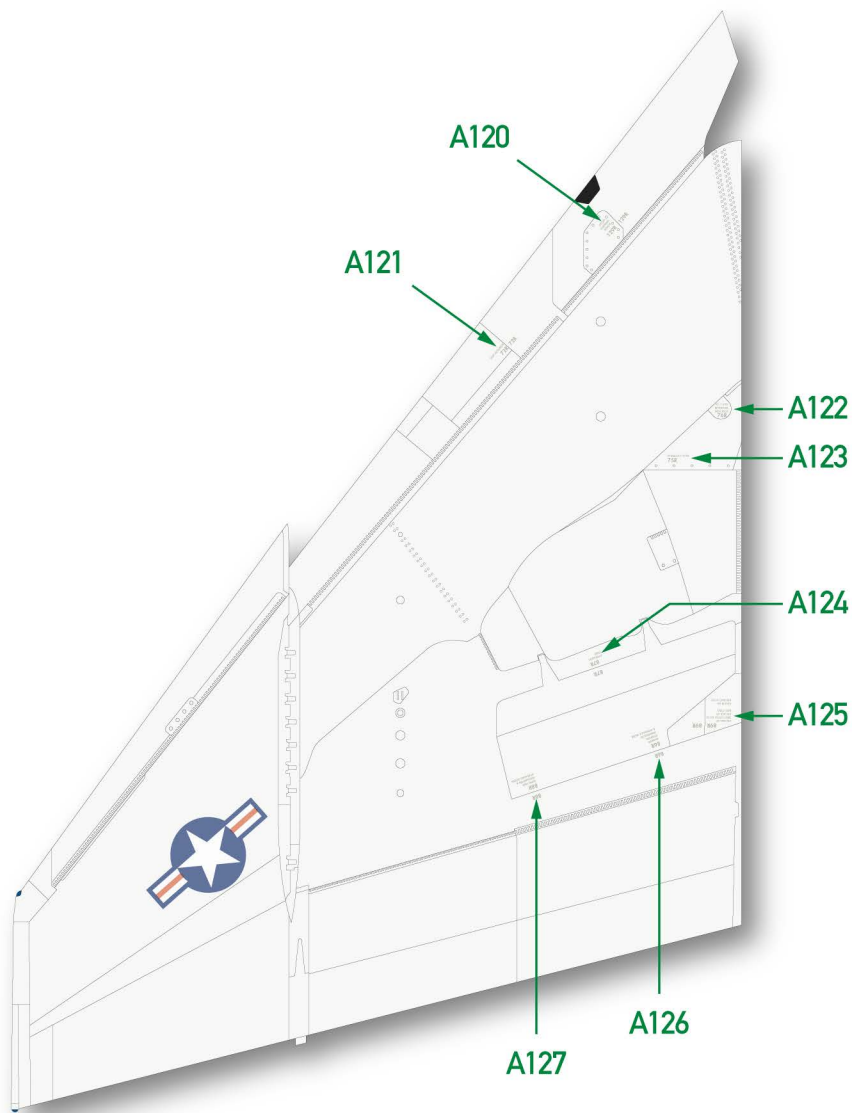

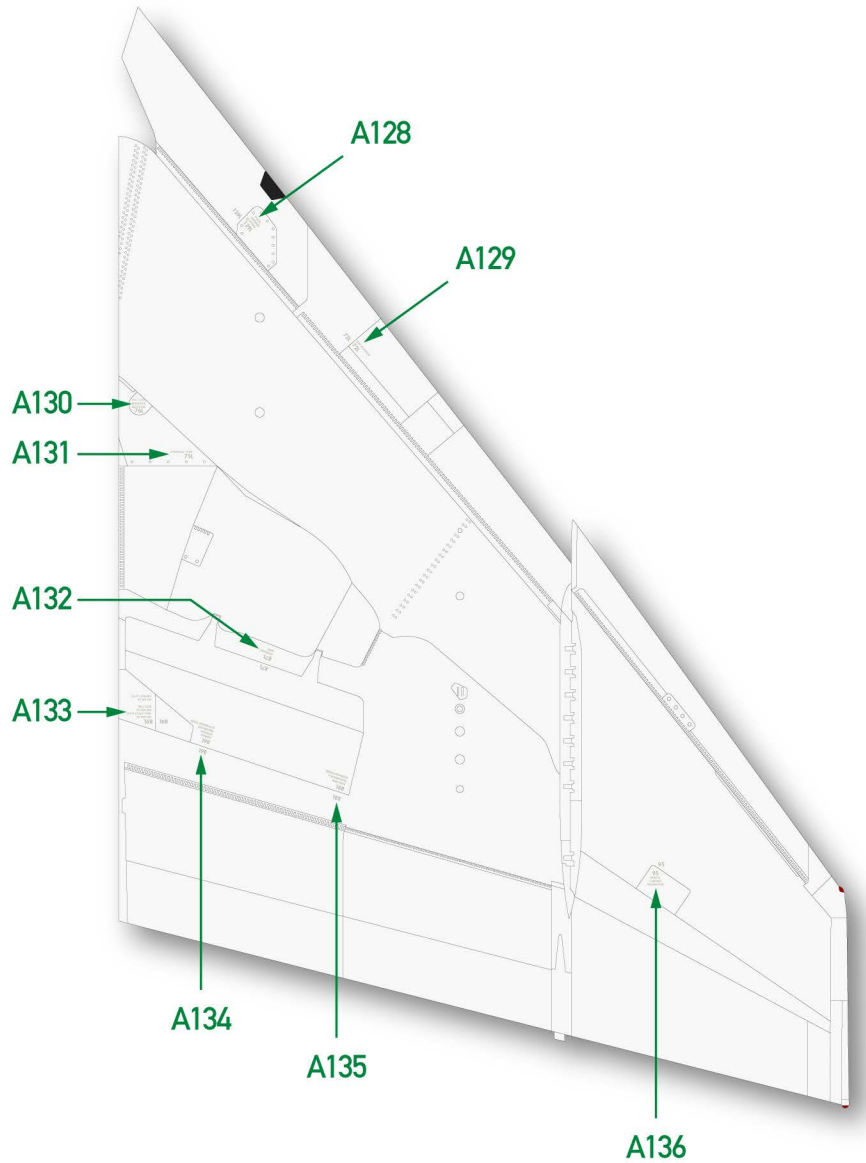

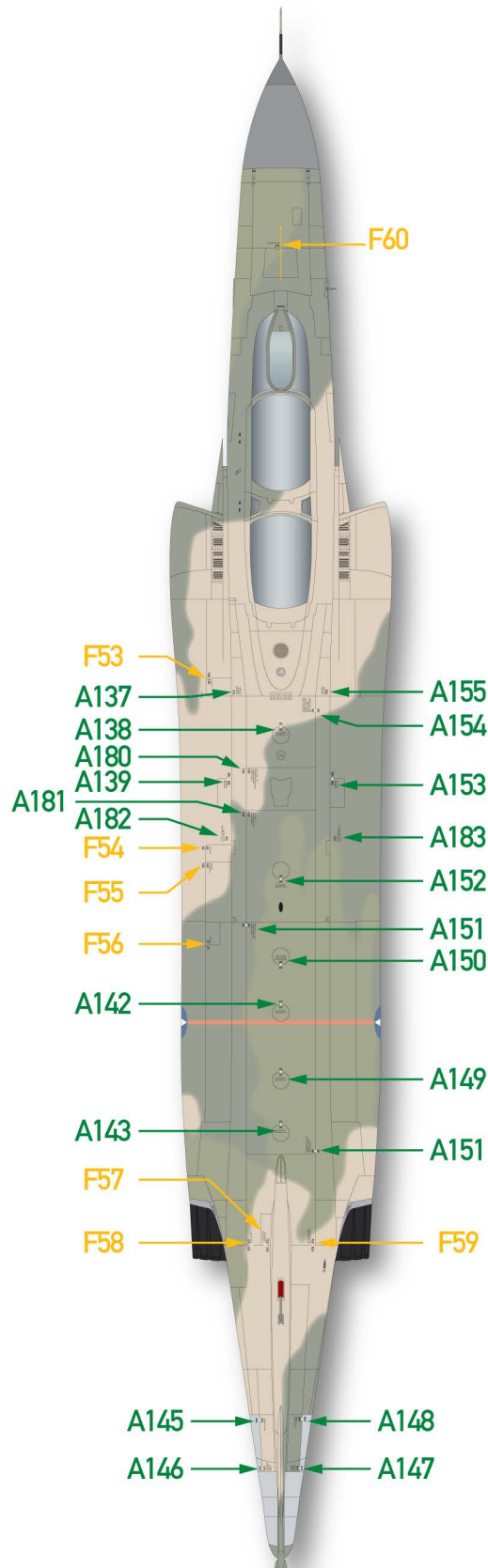

Note:

F75A: 66-0284 - 67-0207

F75B: 67-0208 - 69-7589

F75C: 71-0224 - 71-0236

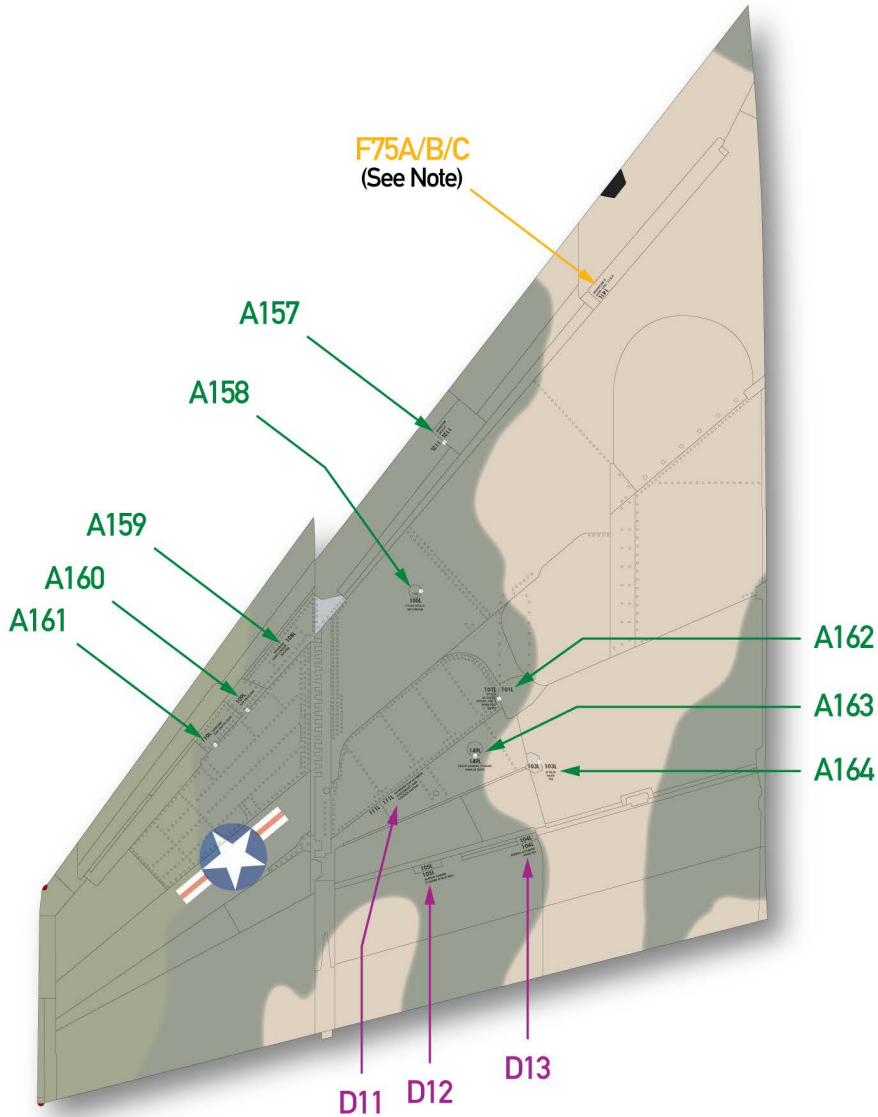

Note:

- F86A: 66-0284 - 67-0207
- F86B: 67-0208 - 69-7589
- F86C: 71-0224 - 71-0236
- F86D: 71-0237 & higher

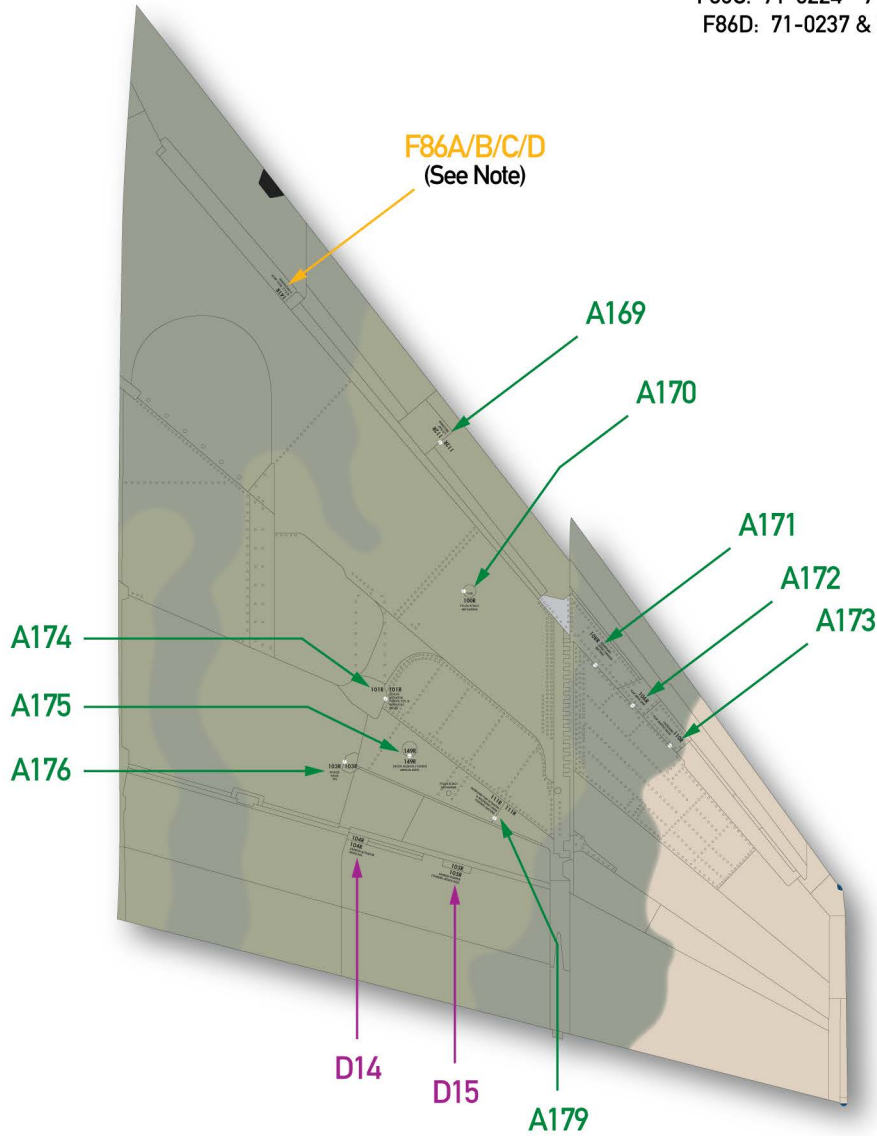

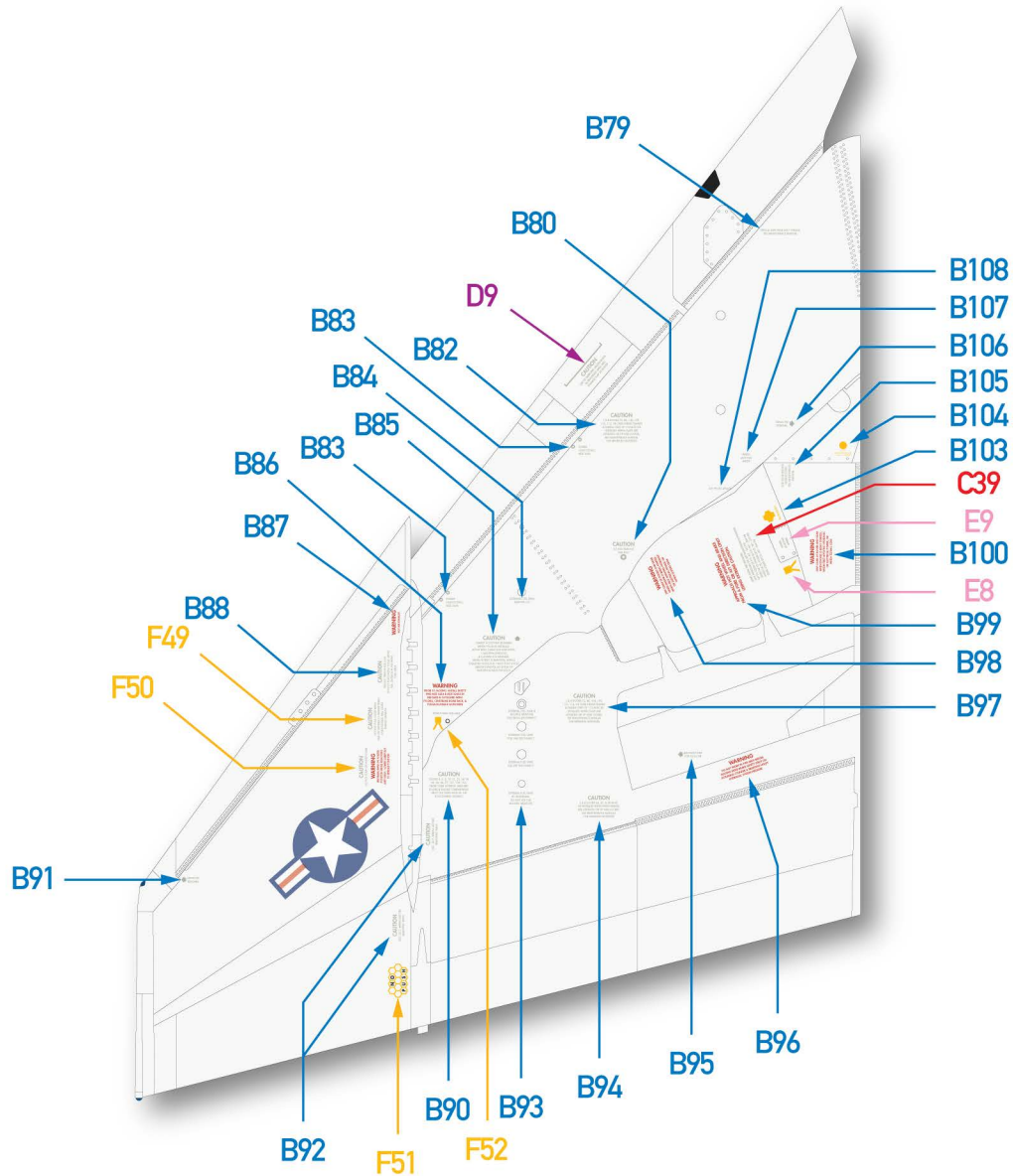

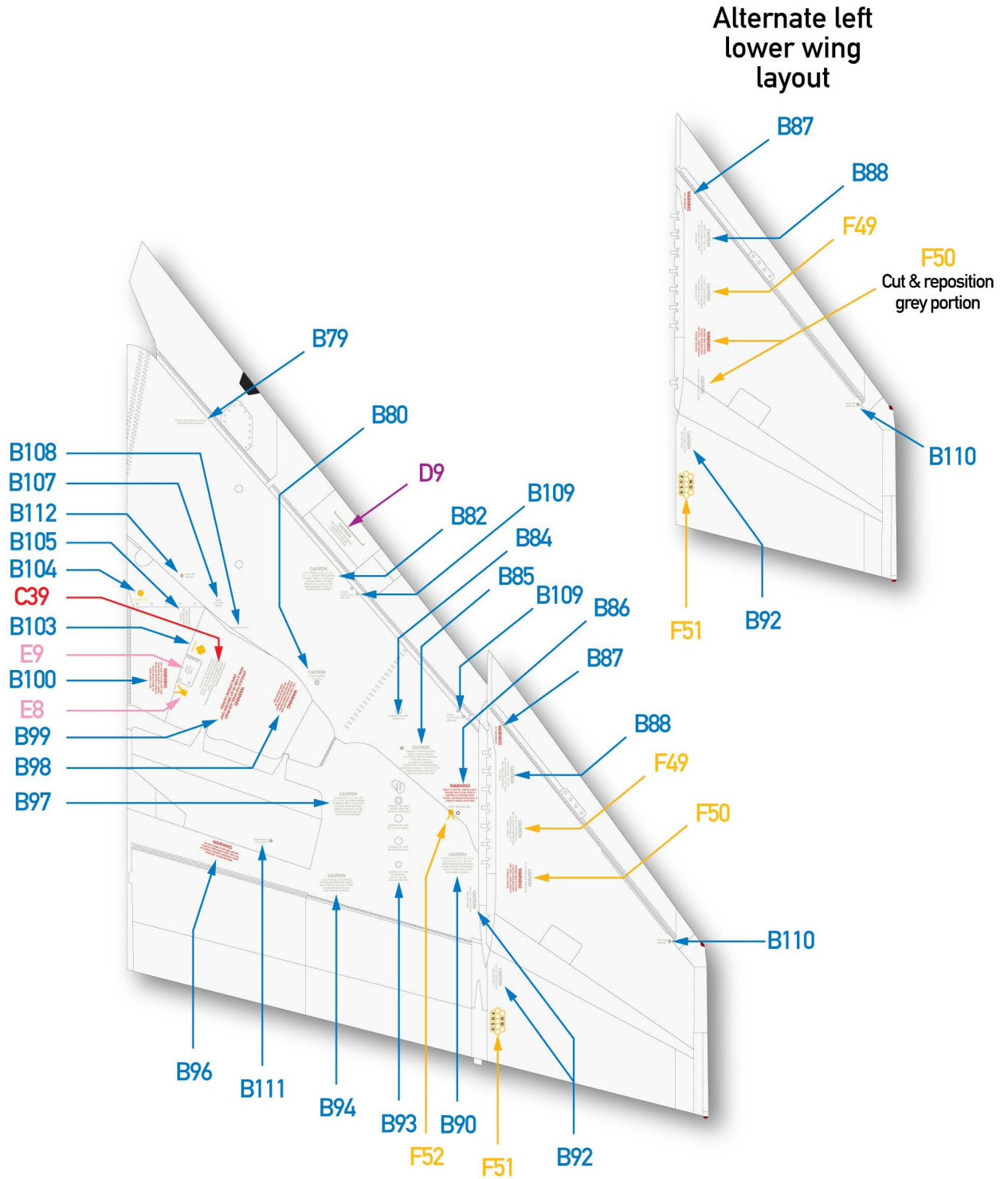

Gun gas purge intake door
variations in application of
warning marking F62

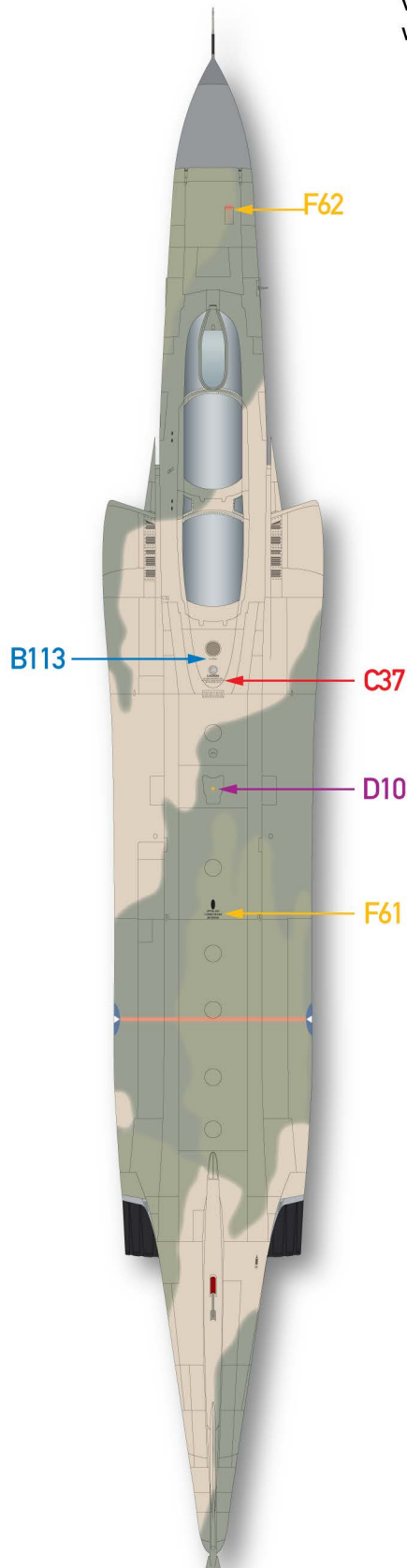

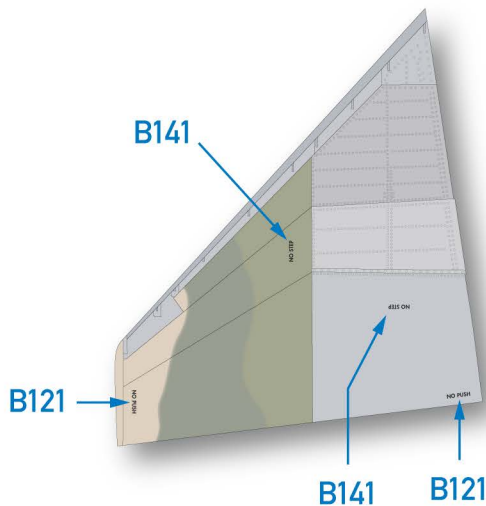
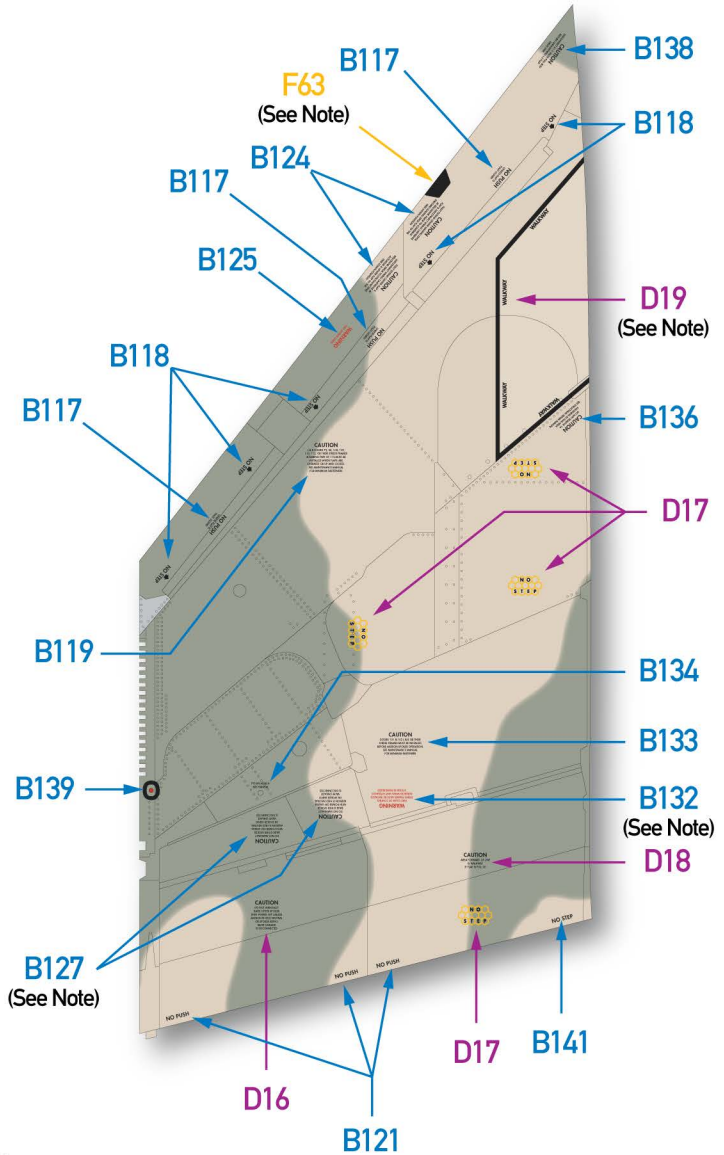
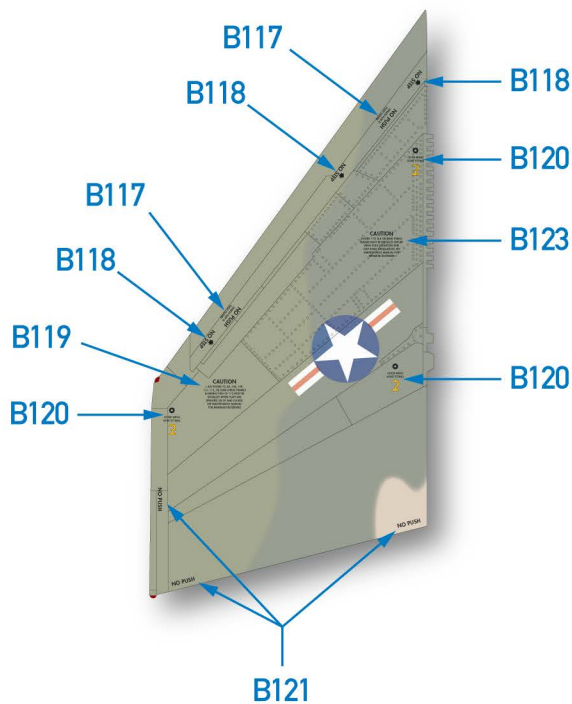

Notes:

B127/B132: Note the orientation of these items. Tops of letters face the trailing edge of the wing.

D19/D20: When applied at the factory, the area inside the walkway outline was finished with tinted Corogard paint. In the few photos we have where you can clearly see this area on a factory finished aircraft, the left hand (tan) Corogard area appears to be slightly lighter in tone than the surrounding camouflage color, while the right hand one (green) appears darker. Of course it quickly became dirty with grime and boot marks. We are not certain of the change over date to the later style (decals F96/F97), but we believe it was prior to serial number 71-0237 with the slatted wing. Check your references.

F63/F64: Note orientation of these items. Only found on hard wing F-4Es and F-4Js. Retained even after slats were retrofitted, though sometimes overpainted on F-4G conversions.

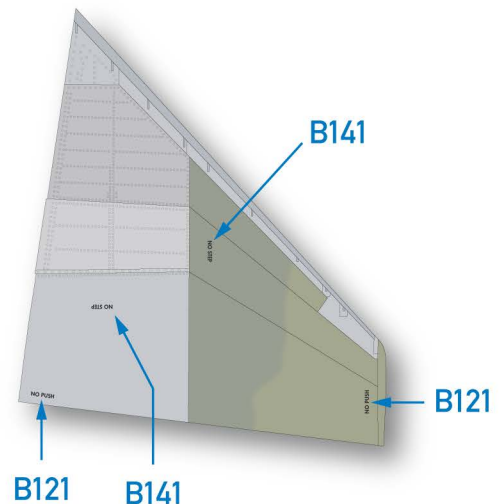
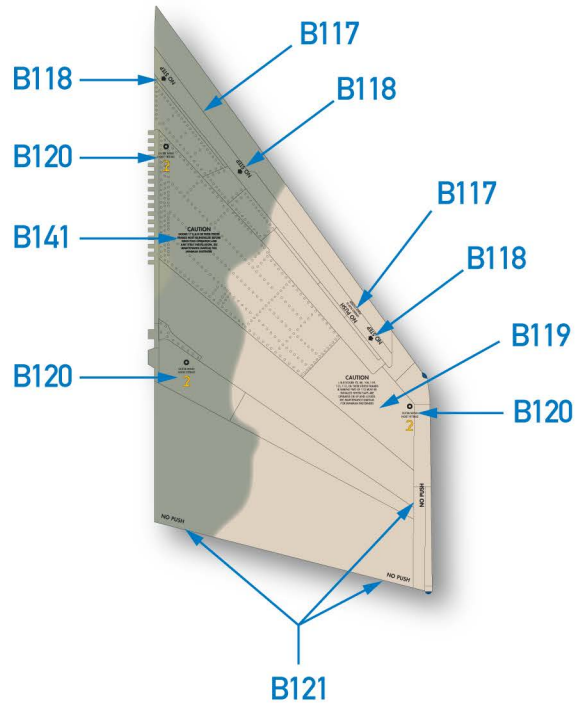
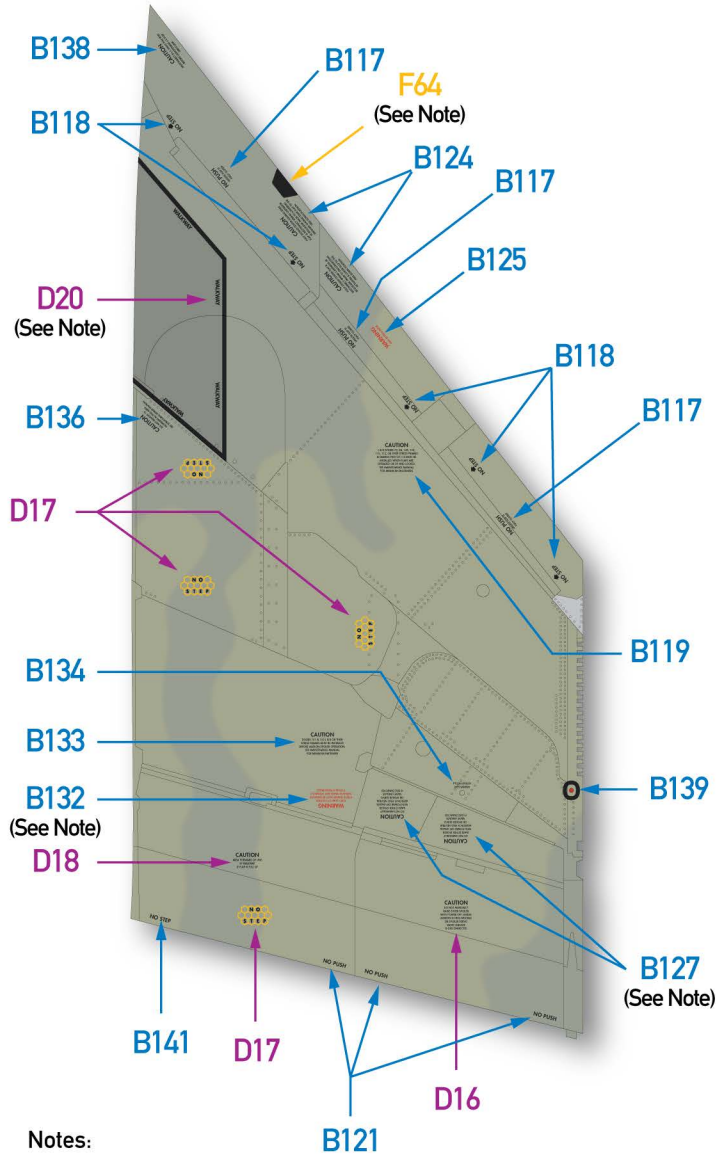

Notes:

B127/B132: Note the orientation of these items. Tops of letters face the trailing edge of the wing.

D19/D20: When applied at the factory, the area inside the walkway outline was finished with tinted Corogard paint. In the few photos we have where you can clearly see this area on a factory finished aircraft, the left hand (tan) Corogard area appears to be slightly lighter in tone than the surrounding camouflage color, while the right hand one (green) appears darker. Of course it quickly became dirty with grime and boot marks. We are not certain of the change over date to the later style (decals F96/F97), but we believe it was prior to serial number 71-0237 with the slatted wing. Check your references.

F63/F64: Note orientation of these items. Only found on hard wing F-4Es and F-4Js. Retained even after slats were retrofitted, though sometimes overpainted on F-4G conversions.

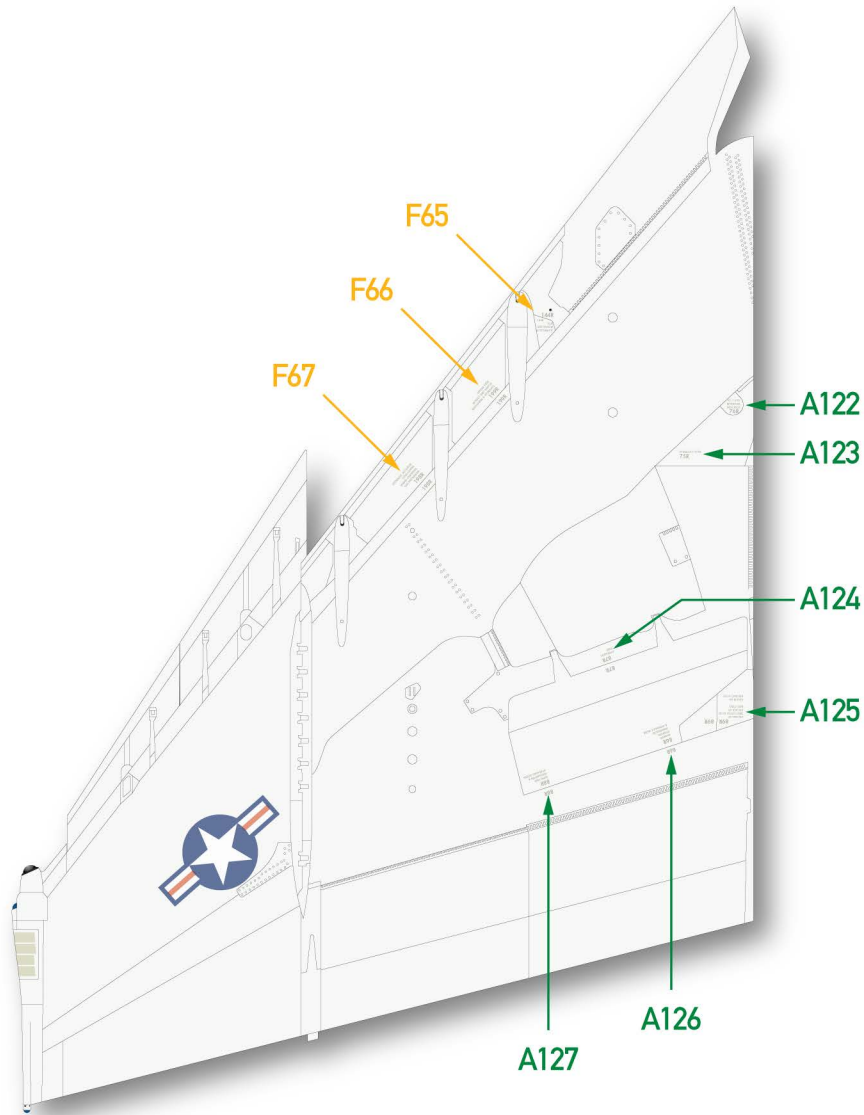

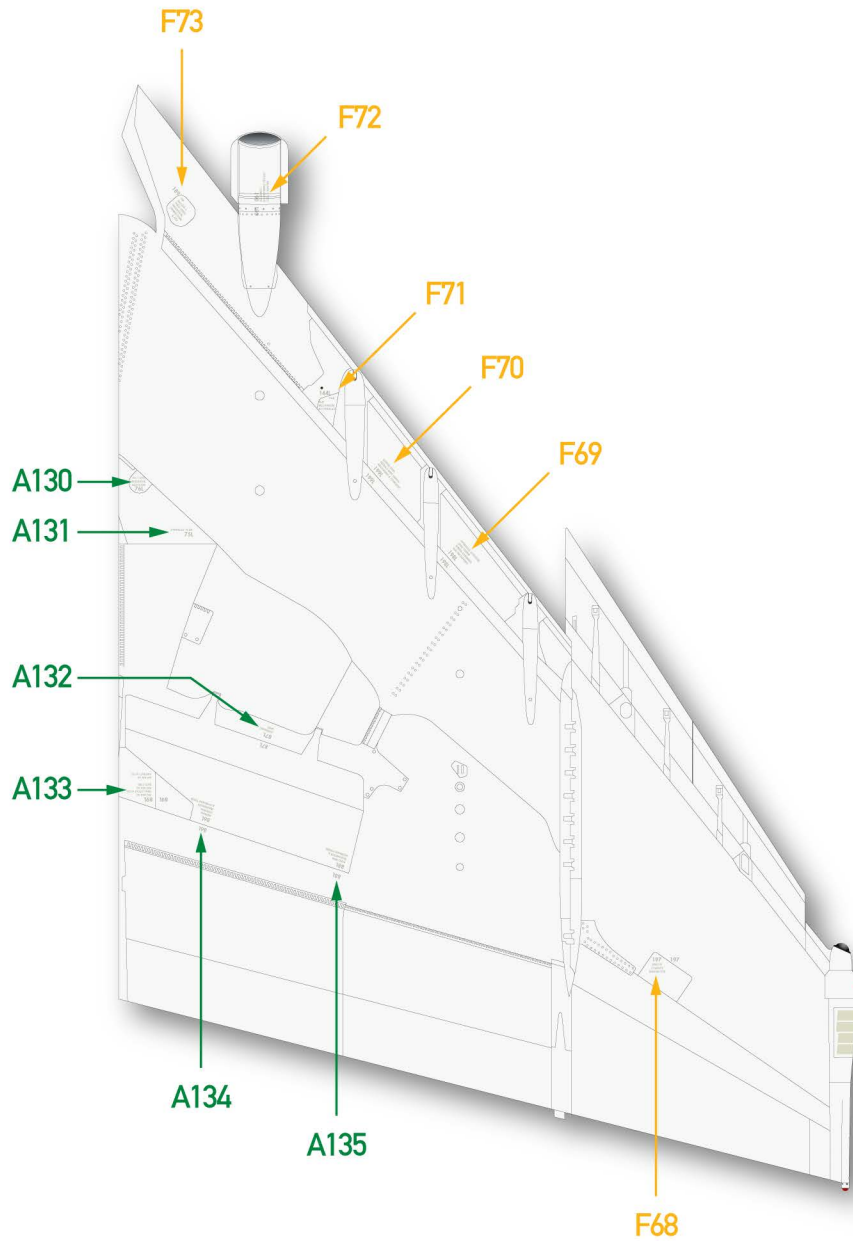

Note:

F75D: 71-0237 - 71-1796

F75E: 72-0121 & higher

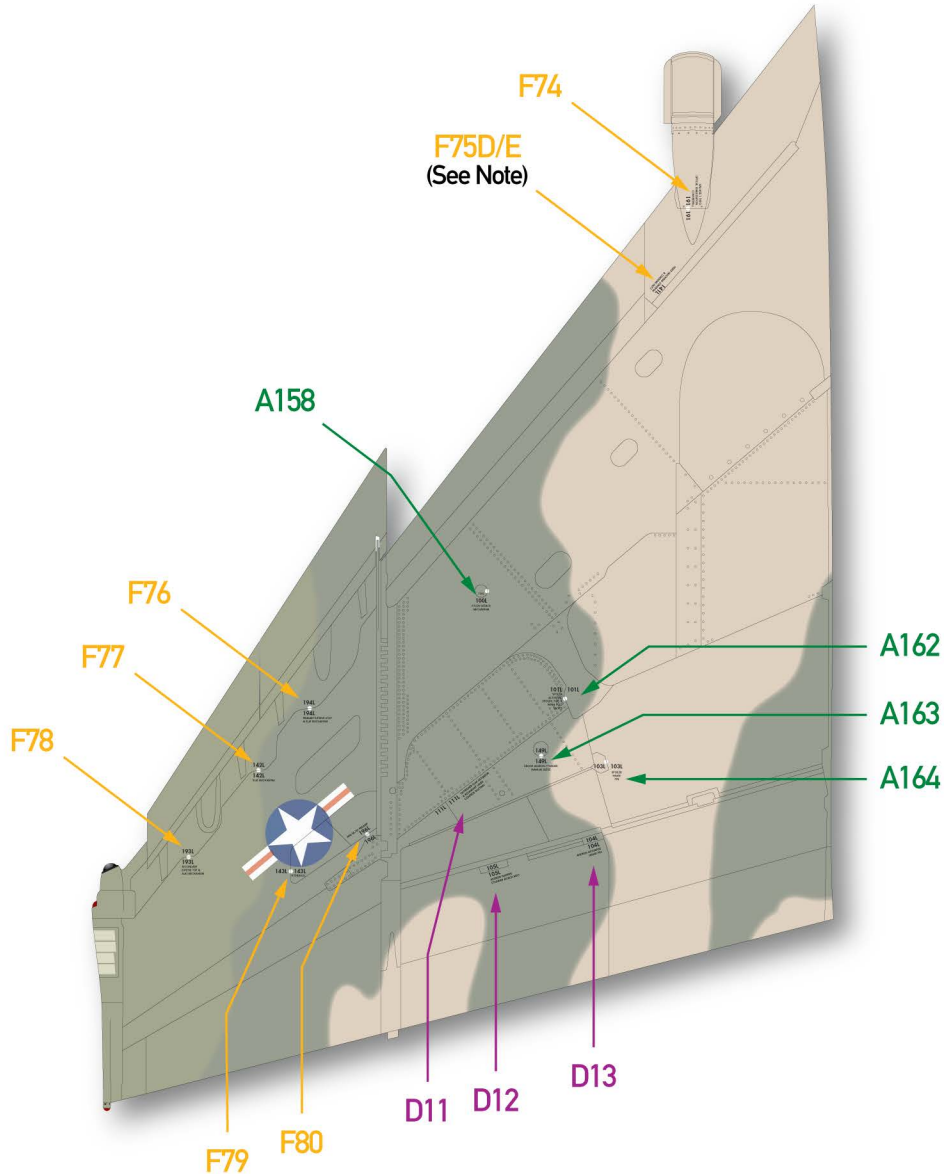

Note:

F86D: 71-0237 & higher

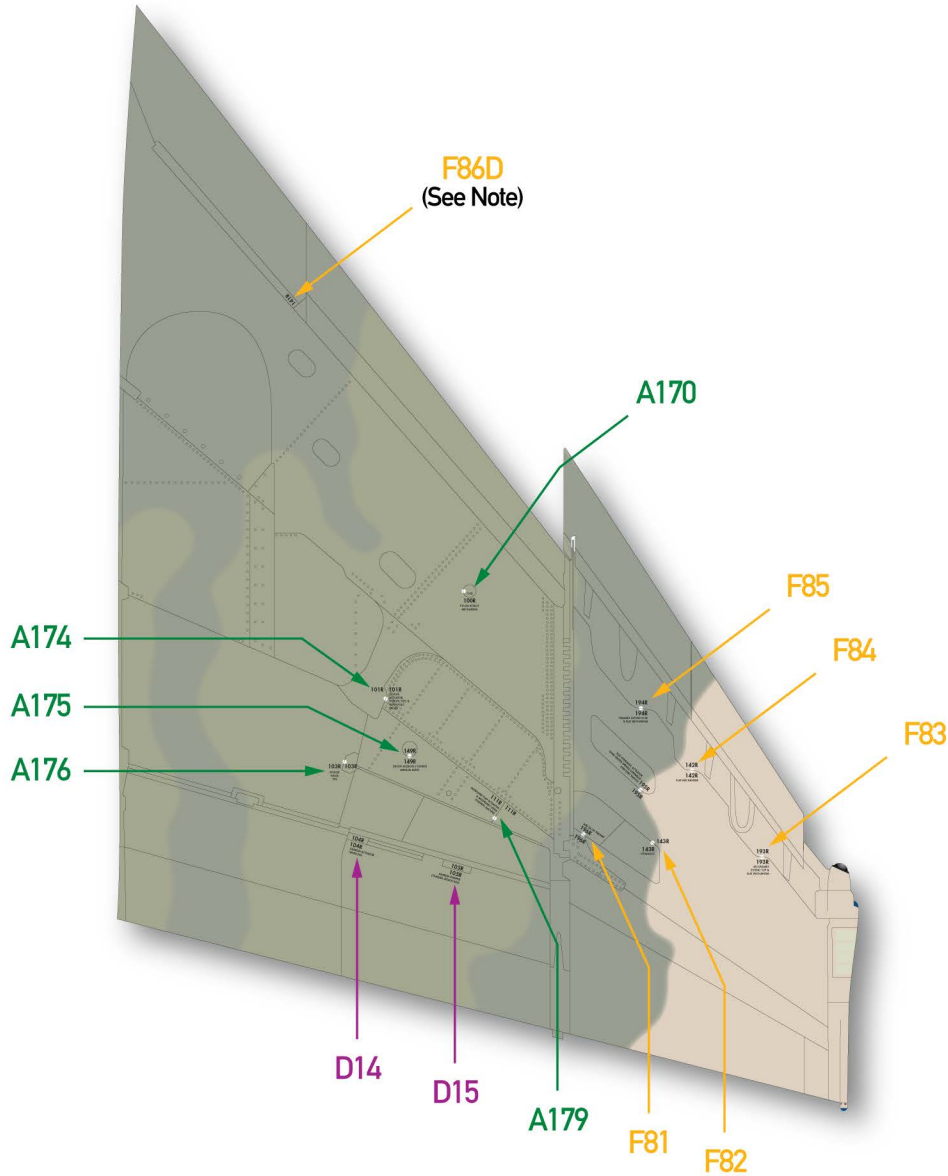

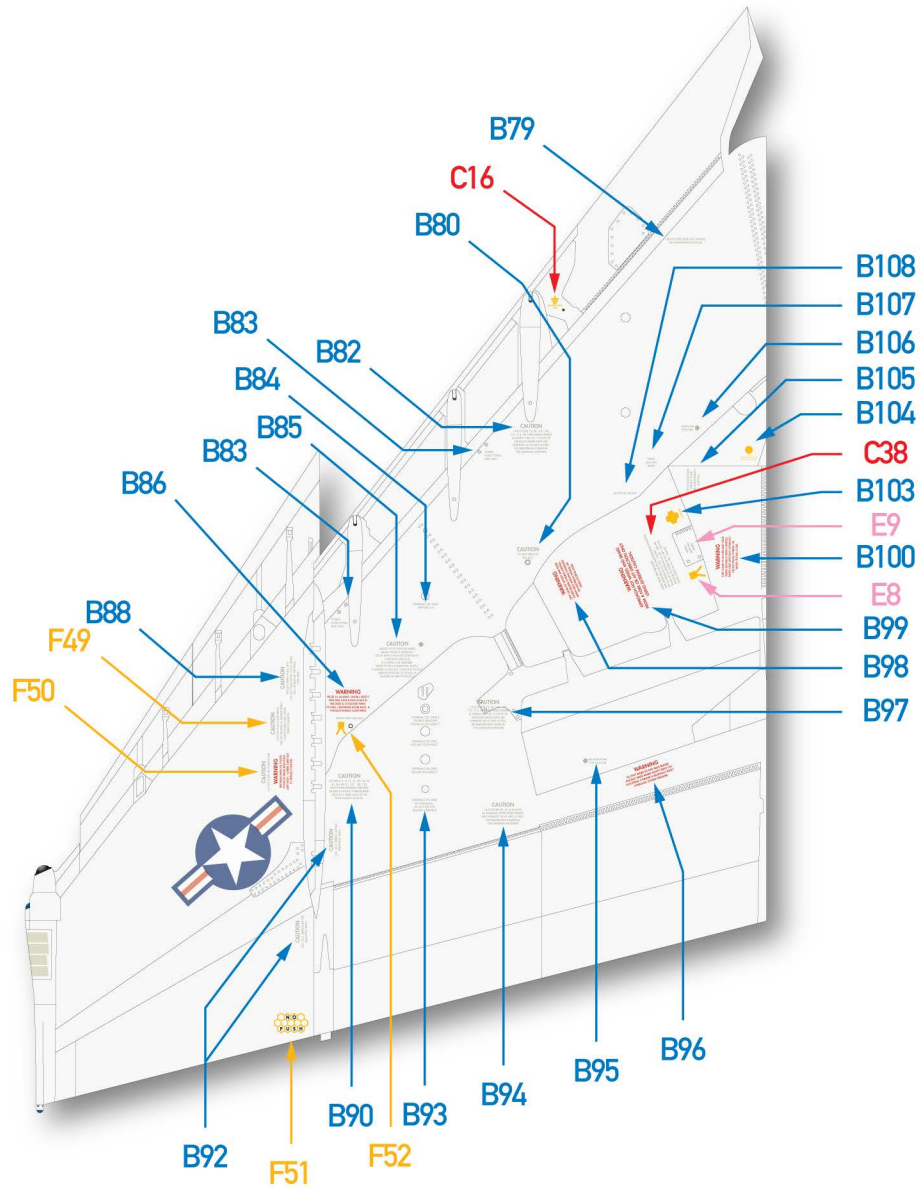

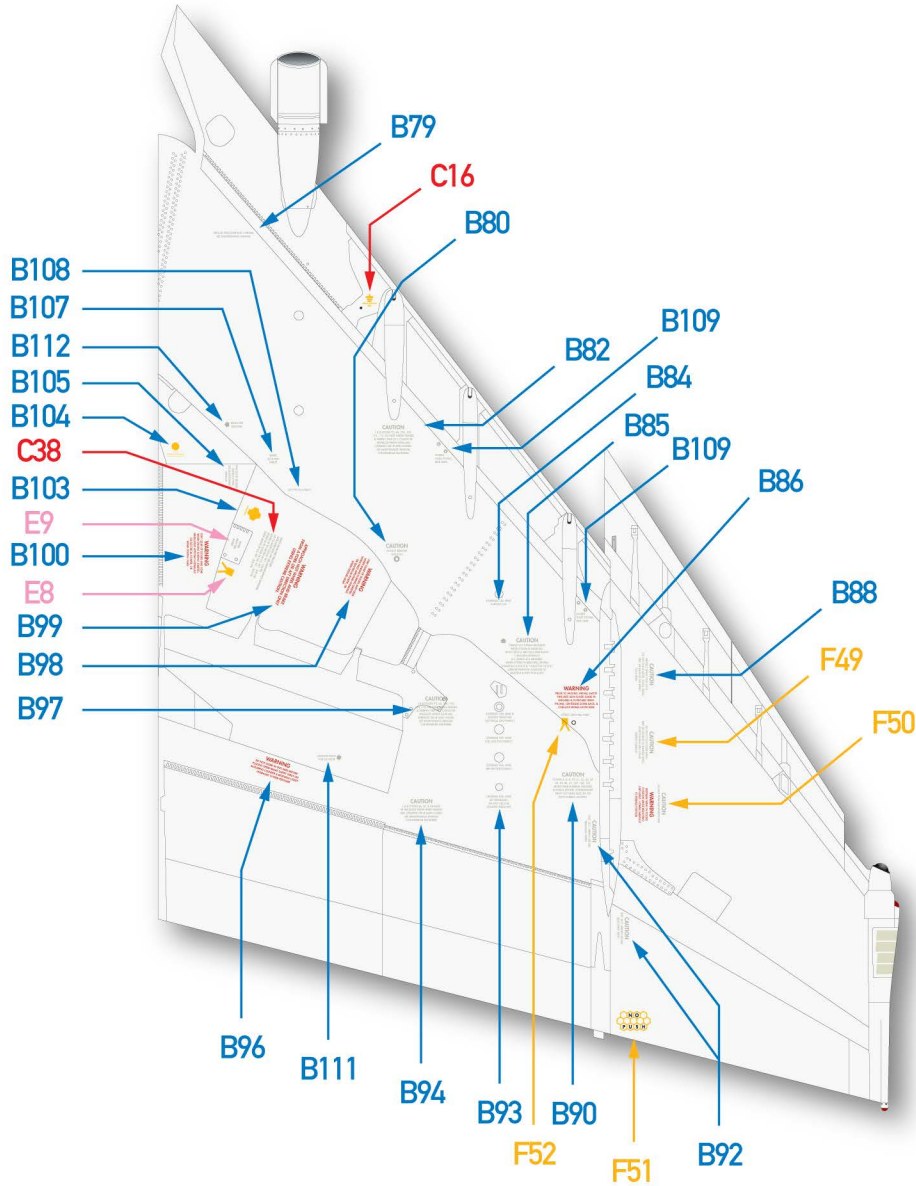

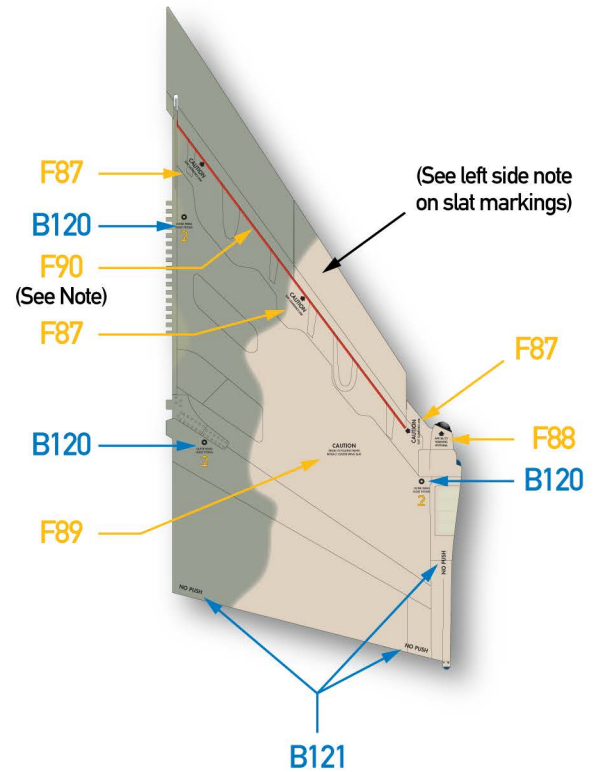
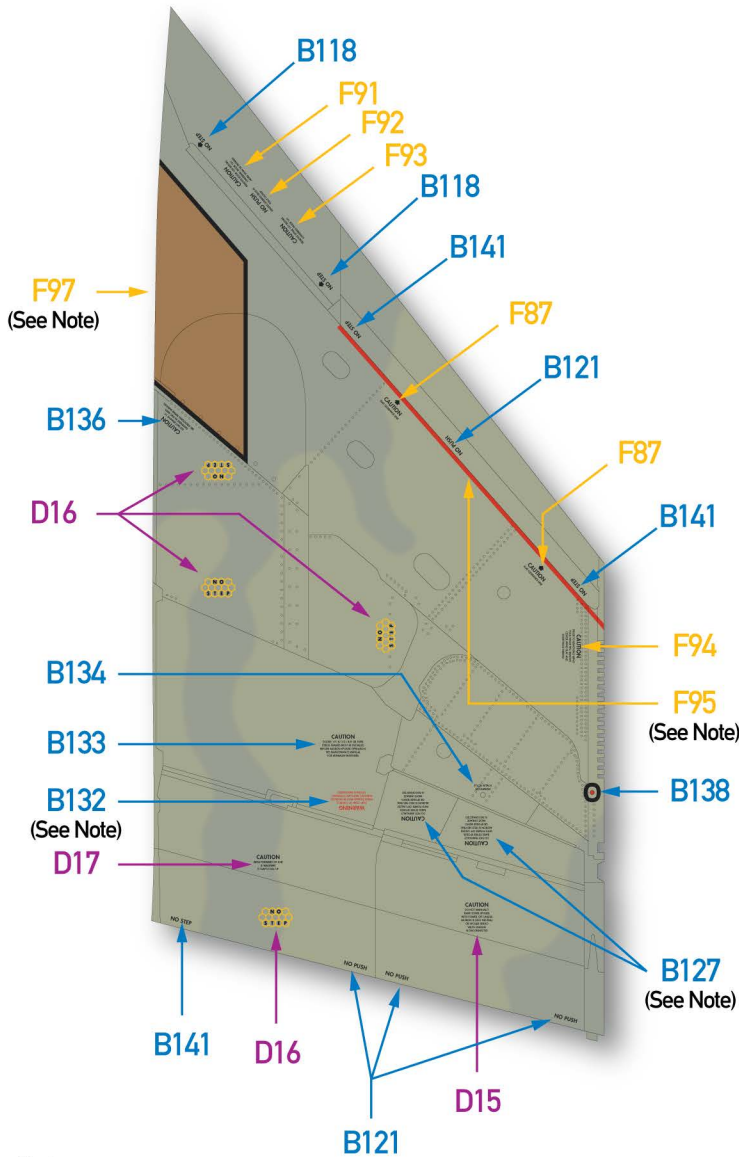

Notes:

B127/B132: Note the orientation of these items. Tops of letters face the trailing edge of the wing.

F90: Red warning line on upper wing surface is centered along aft edge of retracted slat such that only approximately 1/2 of its width is visible from directly above when the outboard slat is in the retracted position. Extra length is provided, trim as shown.

F95: The salmon and bright red versions seem to have been used interchangeably.

F96/F97: The trapezoidal walkway on the wing root is difficult or impossible to see in most photos. We have definitive proof of a brown version. We believe it is intended to be FS 30219, but it is noticeably different from the camouflage color, probably due to the different type and application method of the paint. We believe there was also a dark grey version, but we have not been able to pin down when or why it was used. The brown (and possibly grey) version seems to have come into use in the early to mid-1970s, possibly with the FY72 production blocks (F-4E-50-MC, 72-0121), but nothing firm on this has been uncovered to date. We have photos clearly showing these markings with no "WALKWAY" wording, but we have provided it separately in case you find photos showing it applied. See decals D19/D20 for positioning.

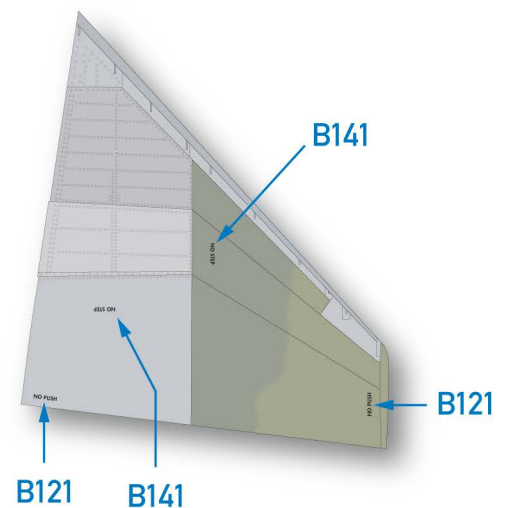

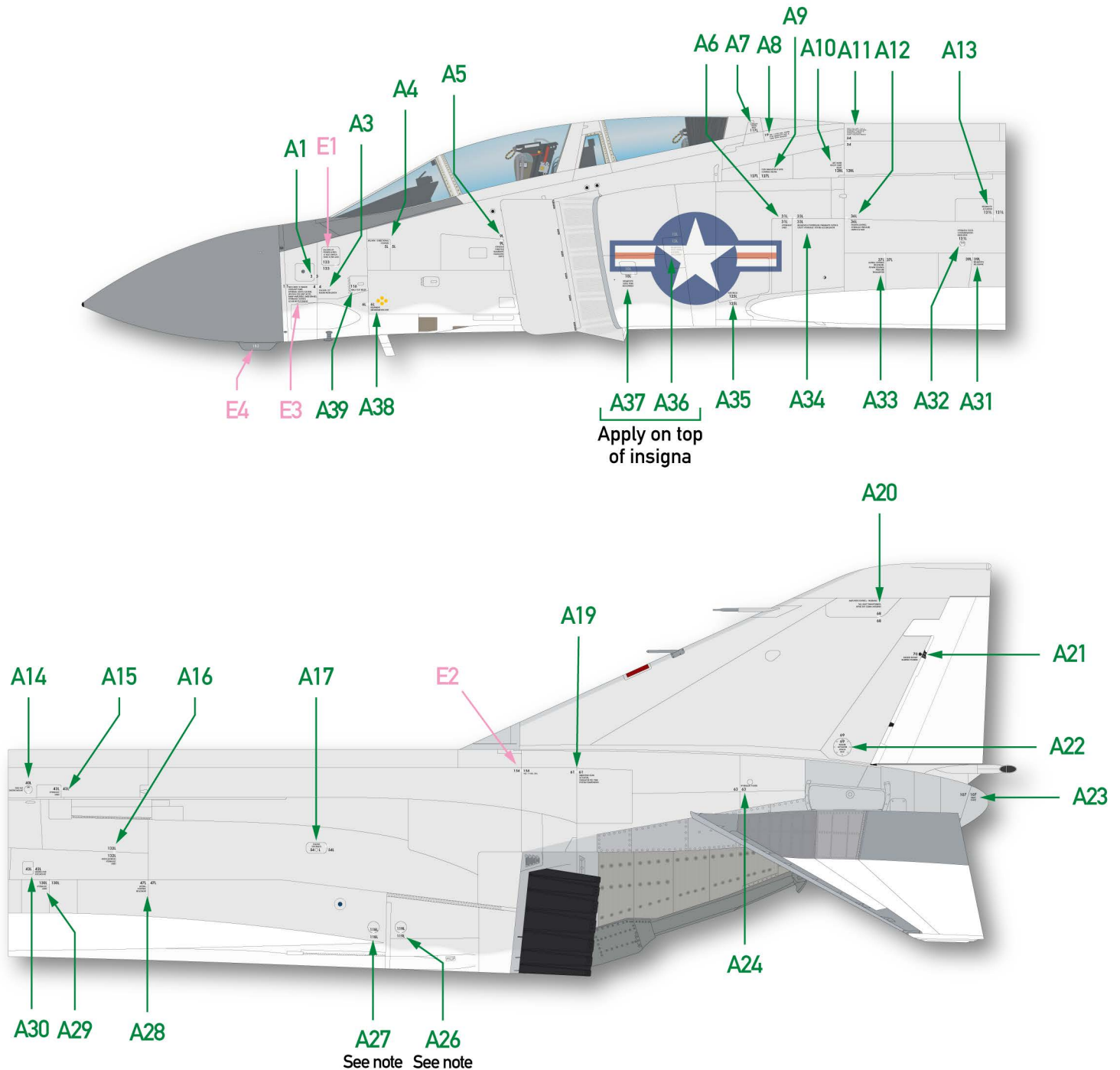

Note: Decals A26 and A27 may be positioned at the top or the bottom of the round access panels, depending on whether the taller "NAVY" or shorter "MARINES" titles were applied. Most F-4Bs, even those that were delivered directly to USMC units, left the factory with "NAVY" applied, with these items positioned as shown.

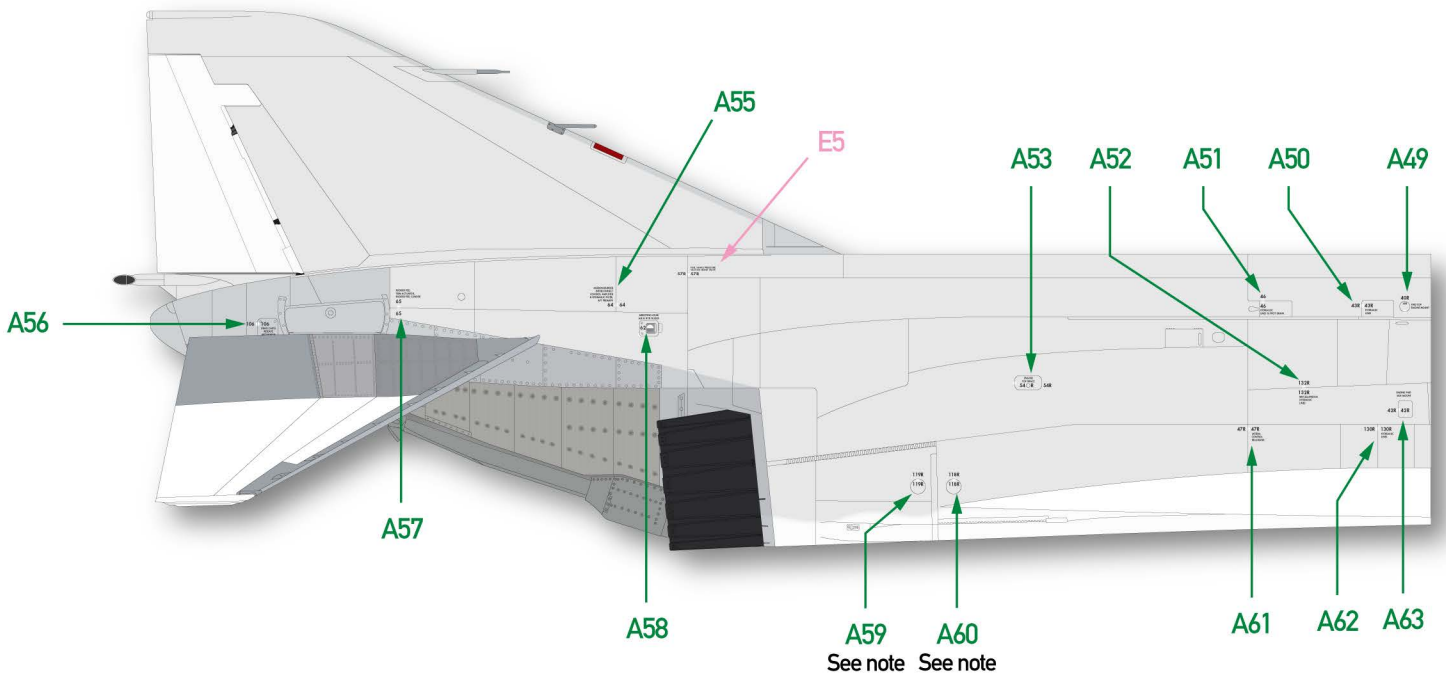
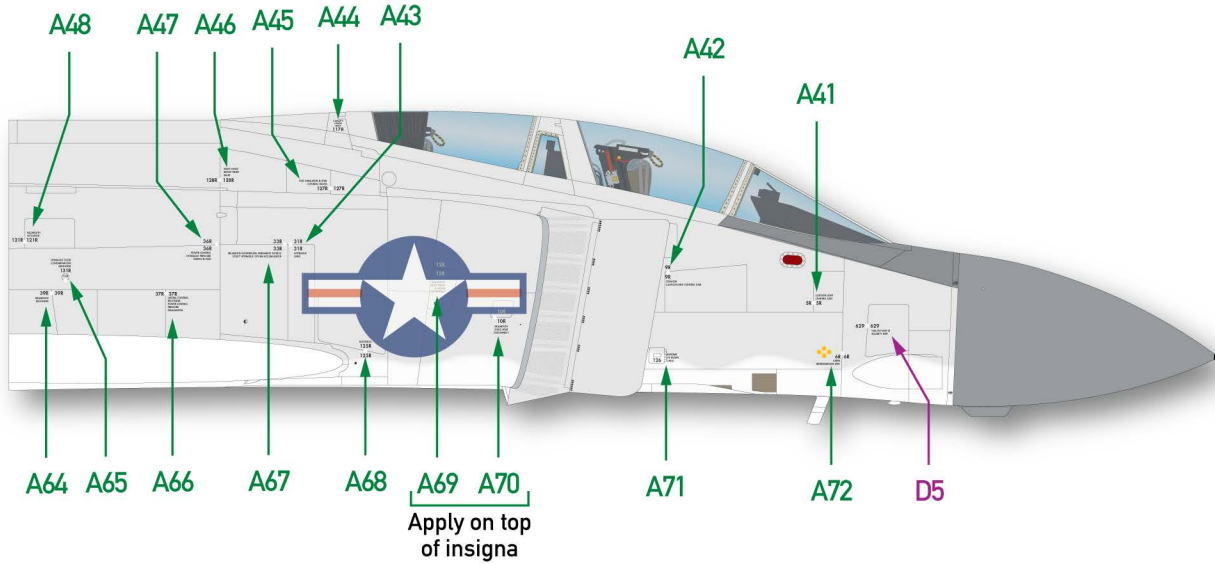

Note: Decals A59 and A60 may be positioned at the top or the bottom of the round access panels, depending on whether the taller "NAVY" or shorter "MARINES" titles were applied. Most F-4Bs, even those that were delivered directly to USMC units, left the factory with "NAVY" applied, with these items positioned as shown.

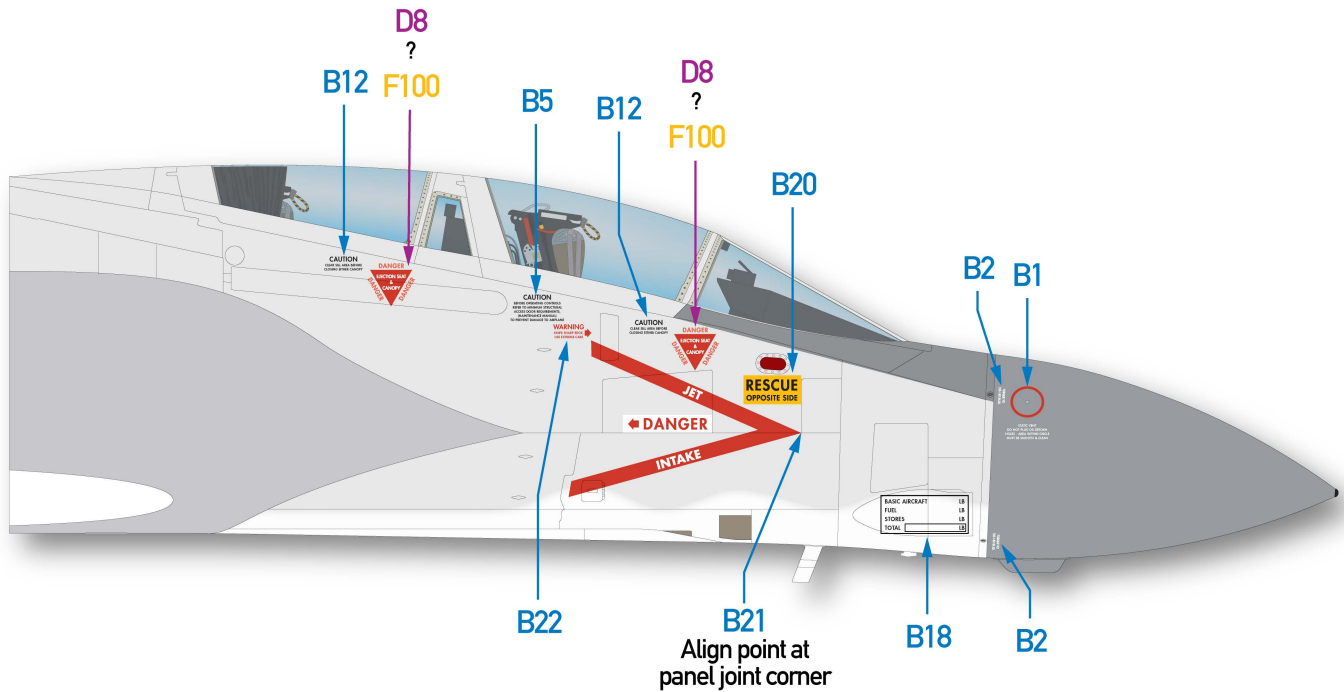
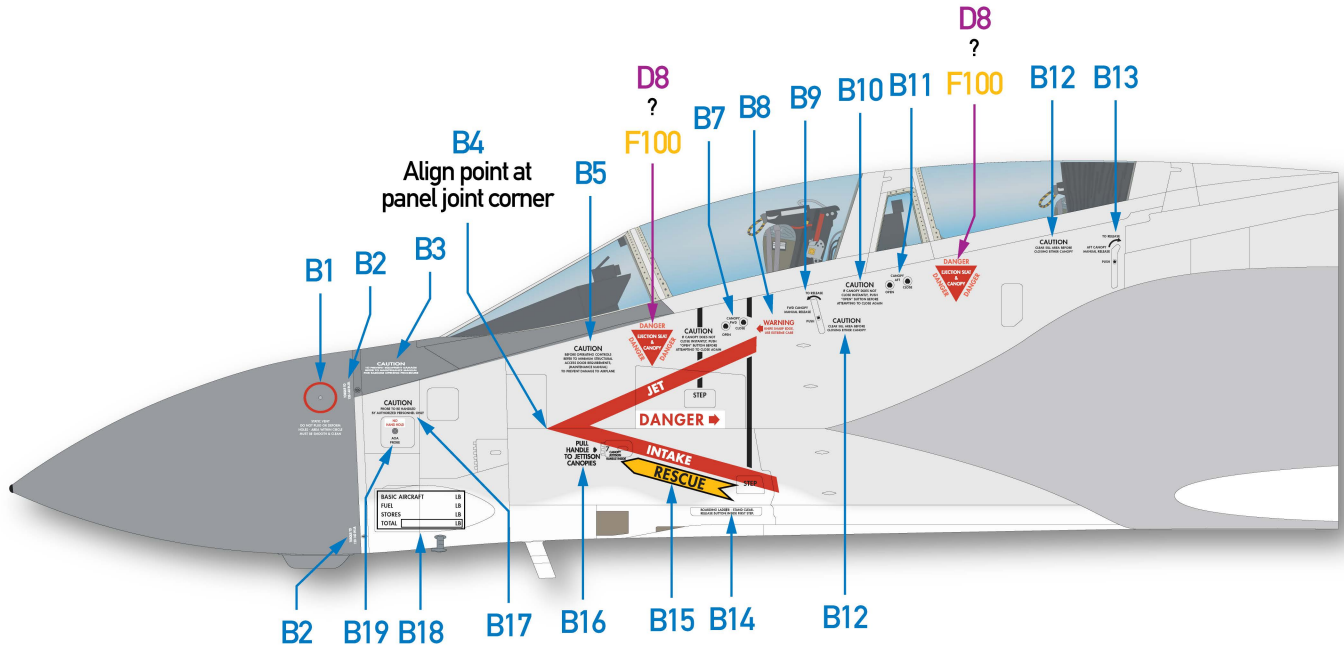

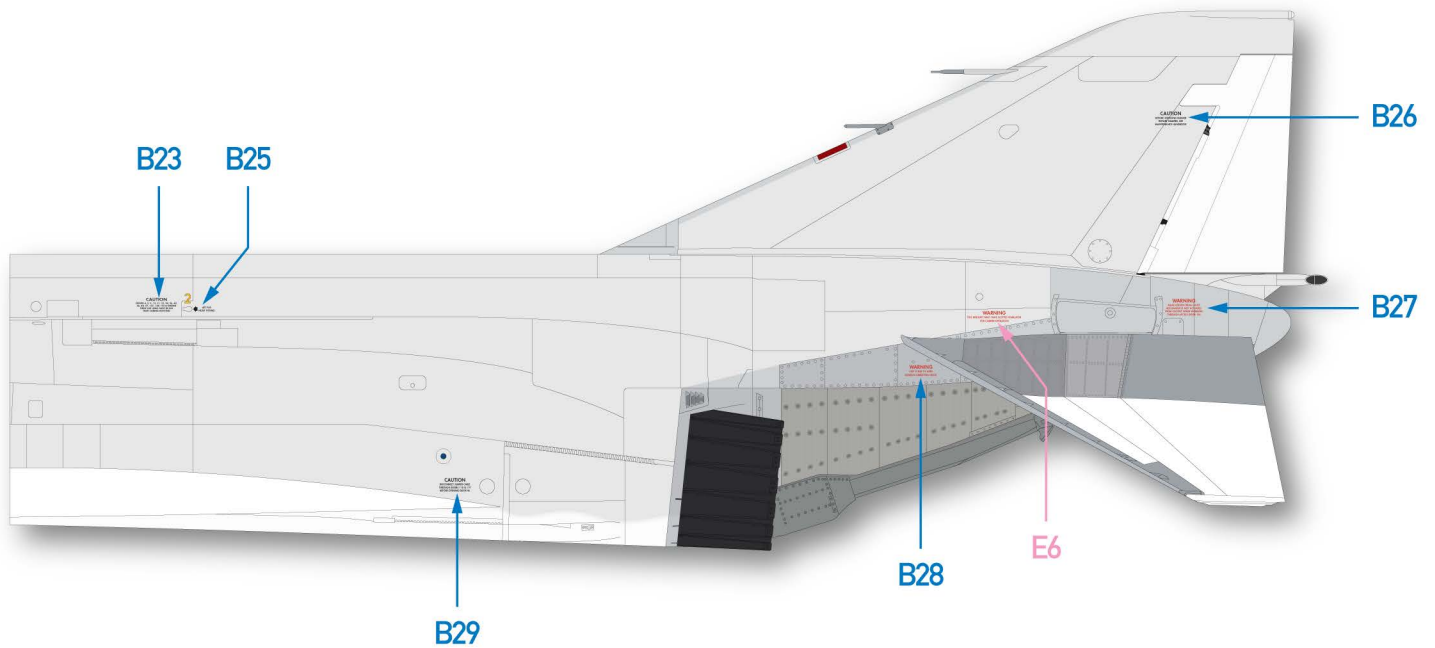
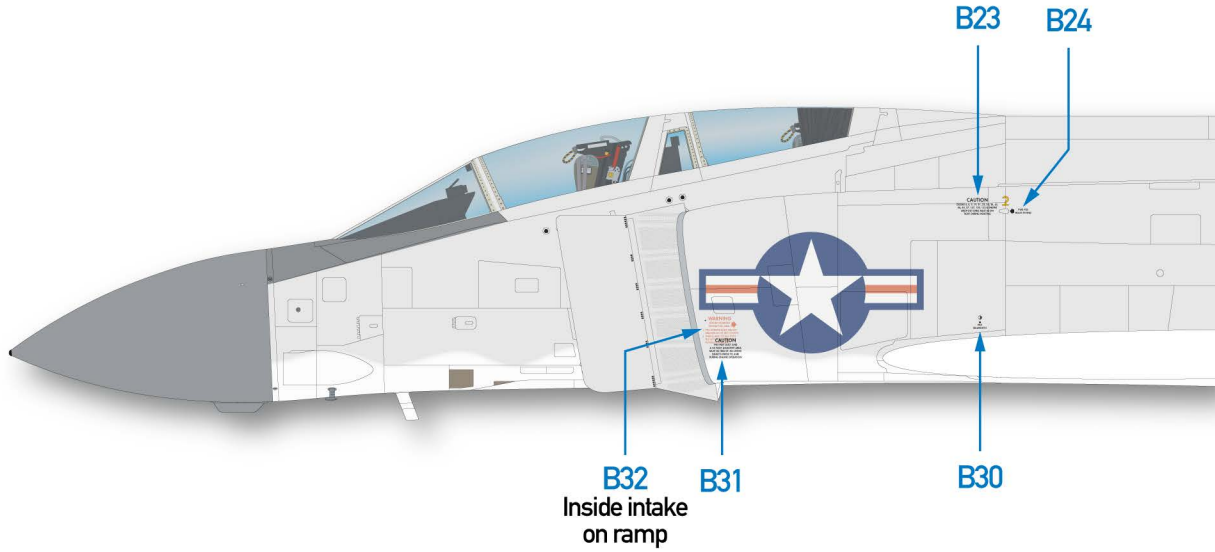

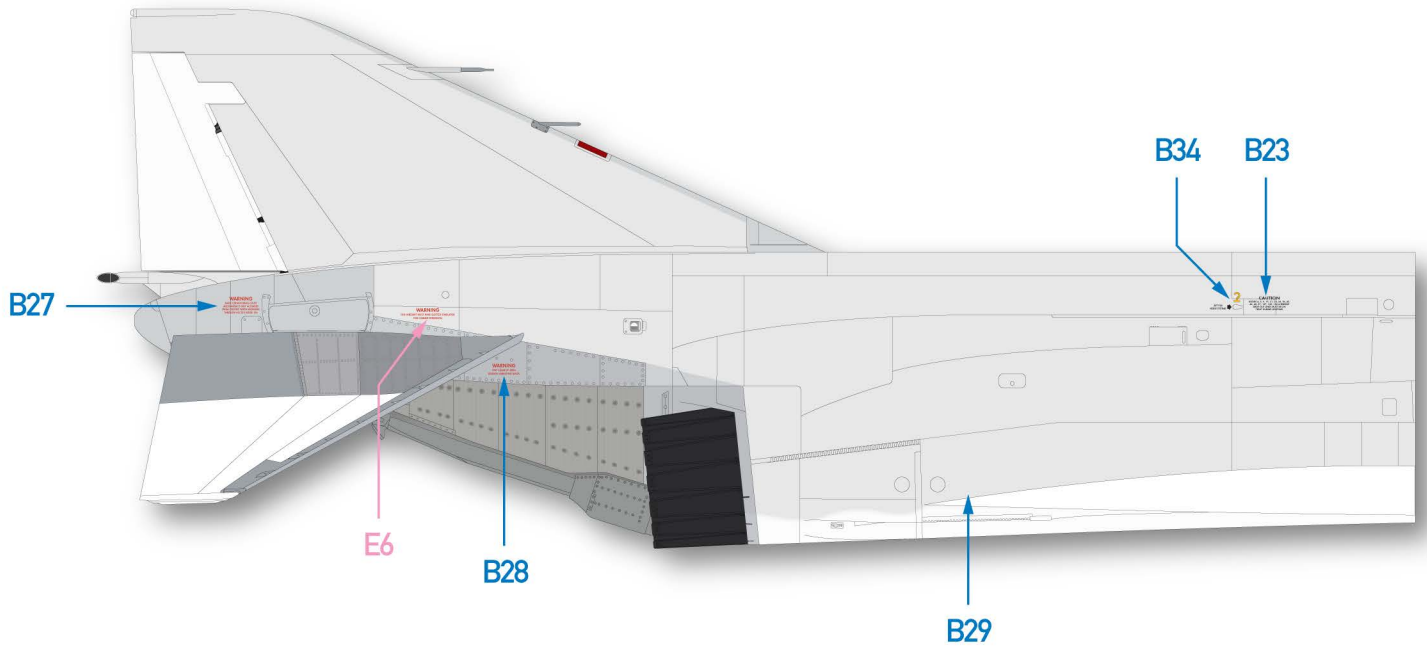
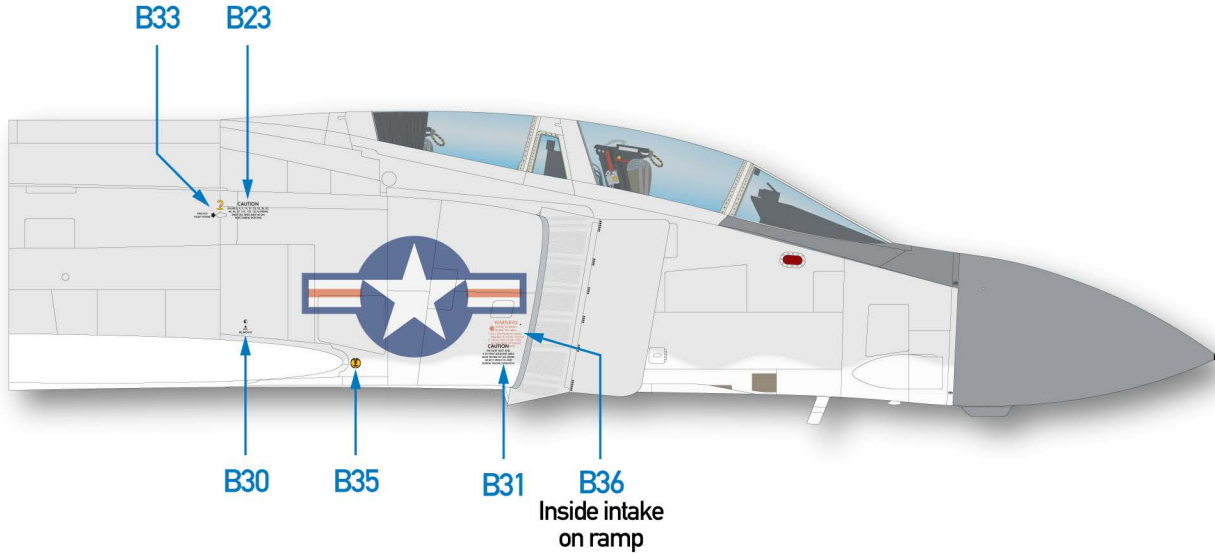

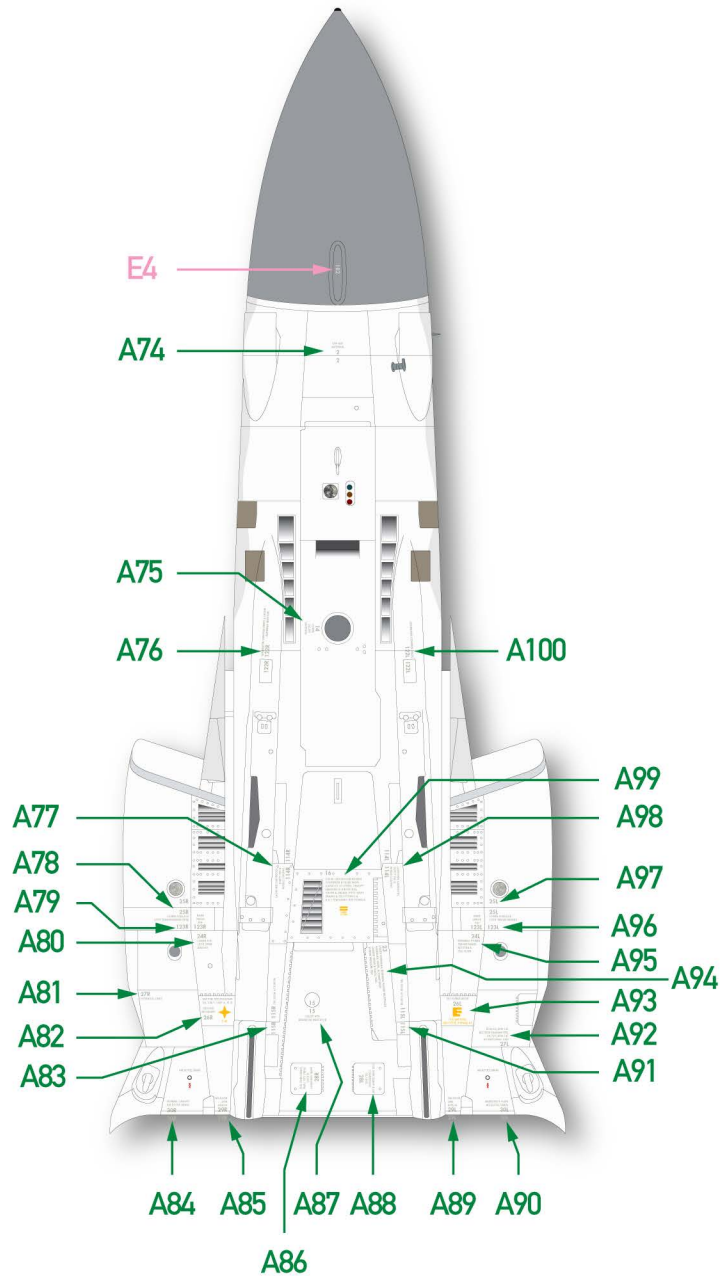

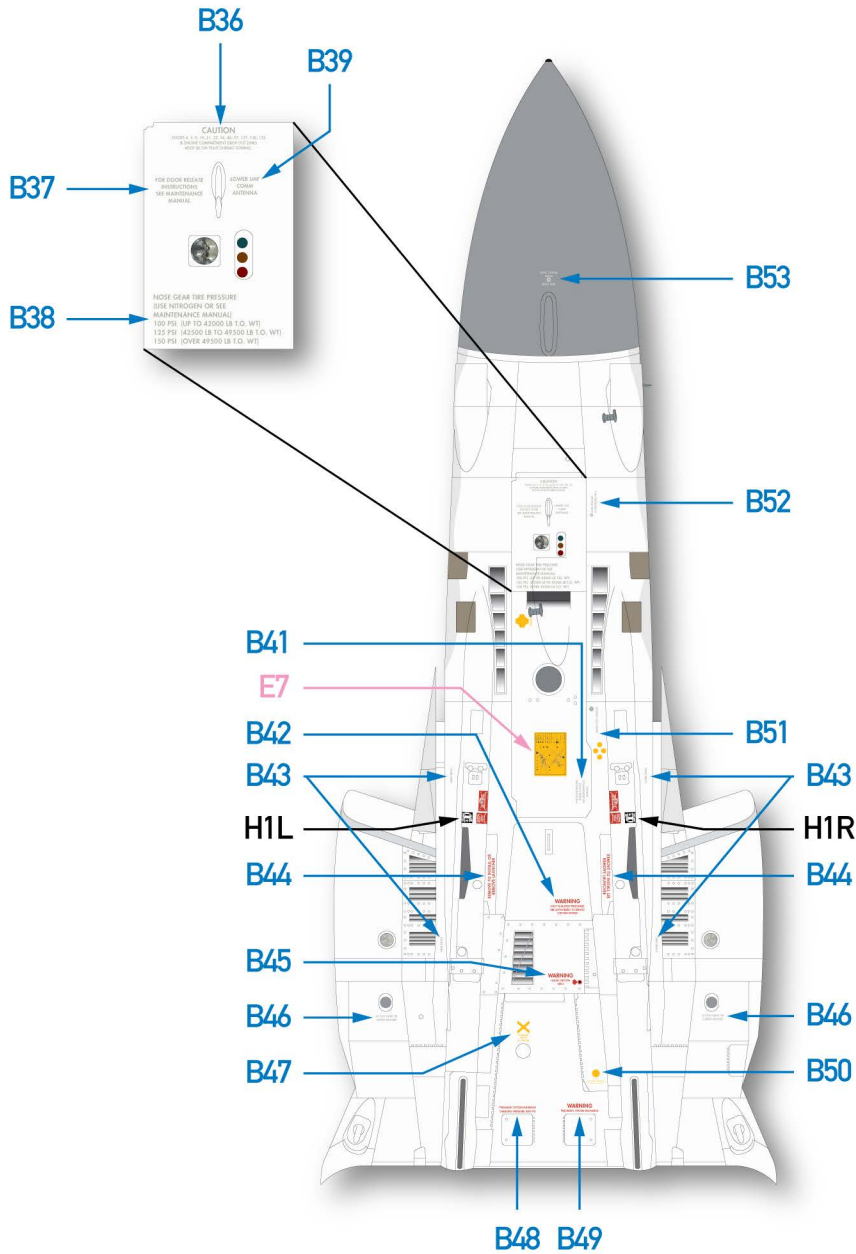

↑
Forward

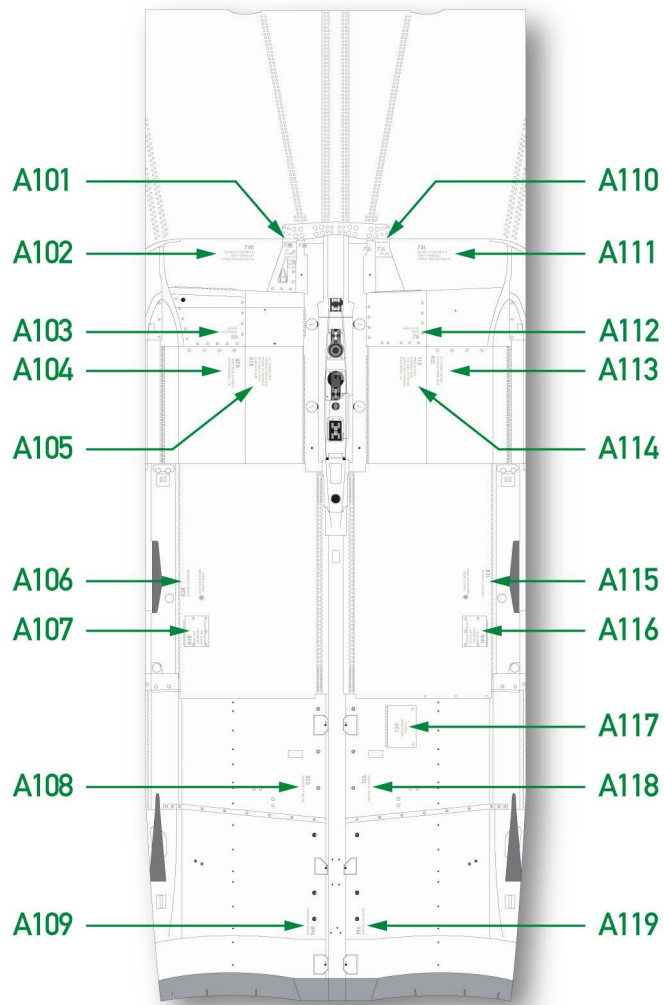

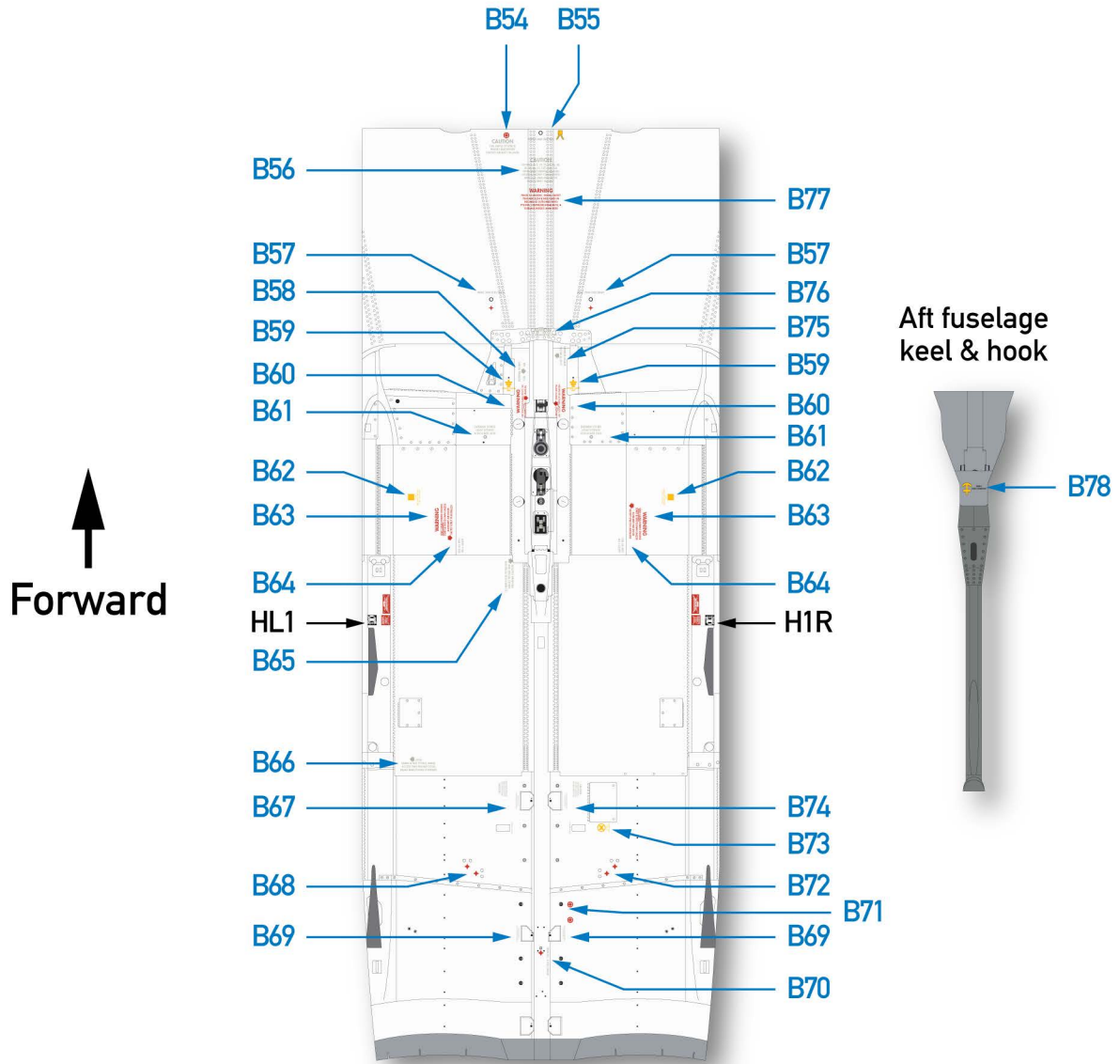

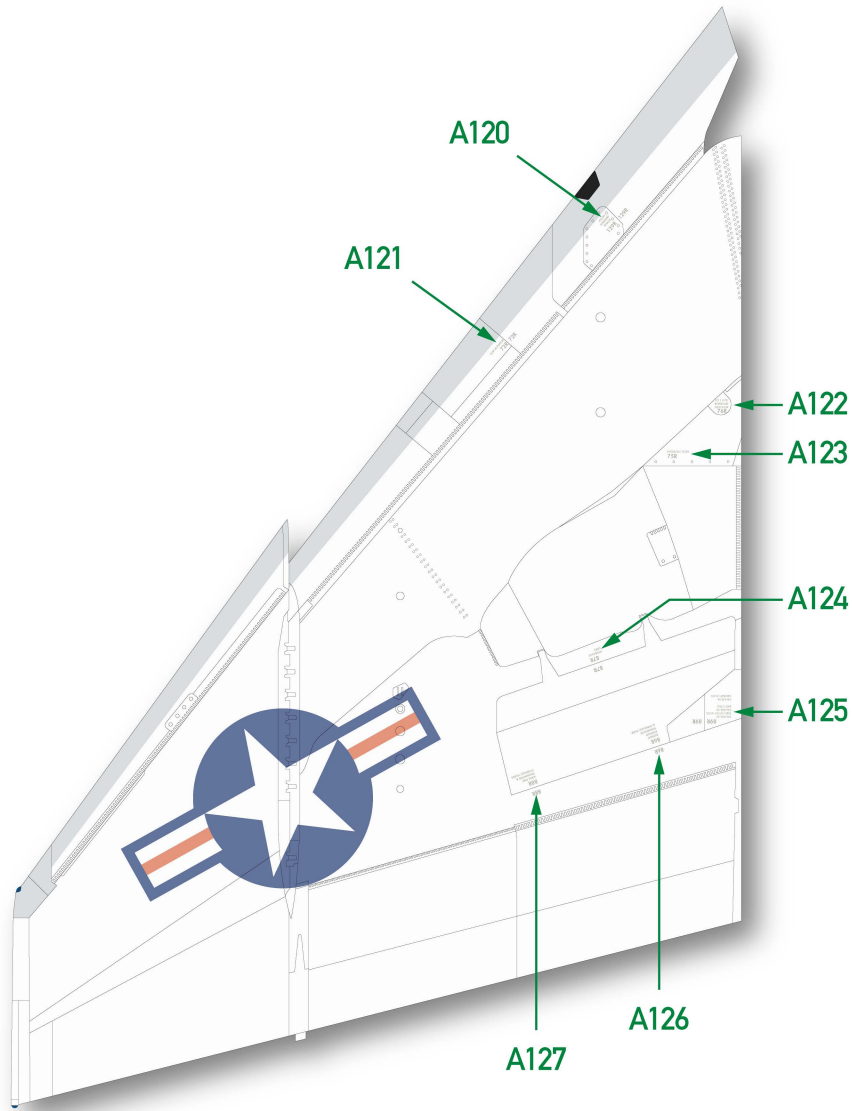

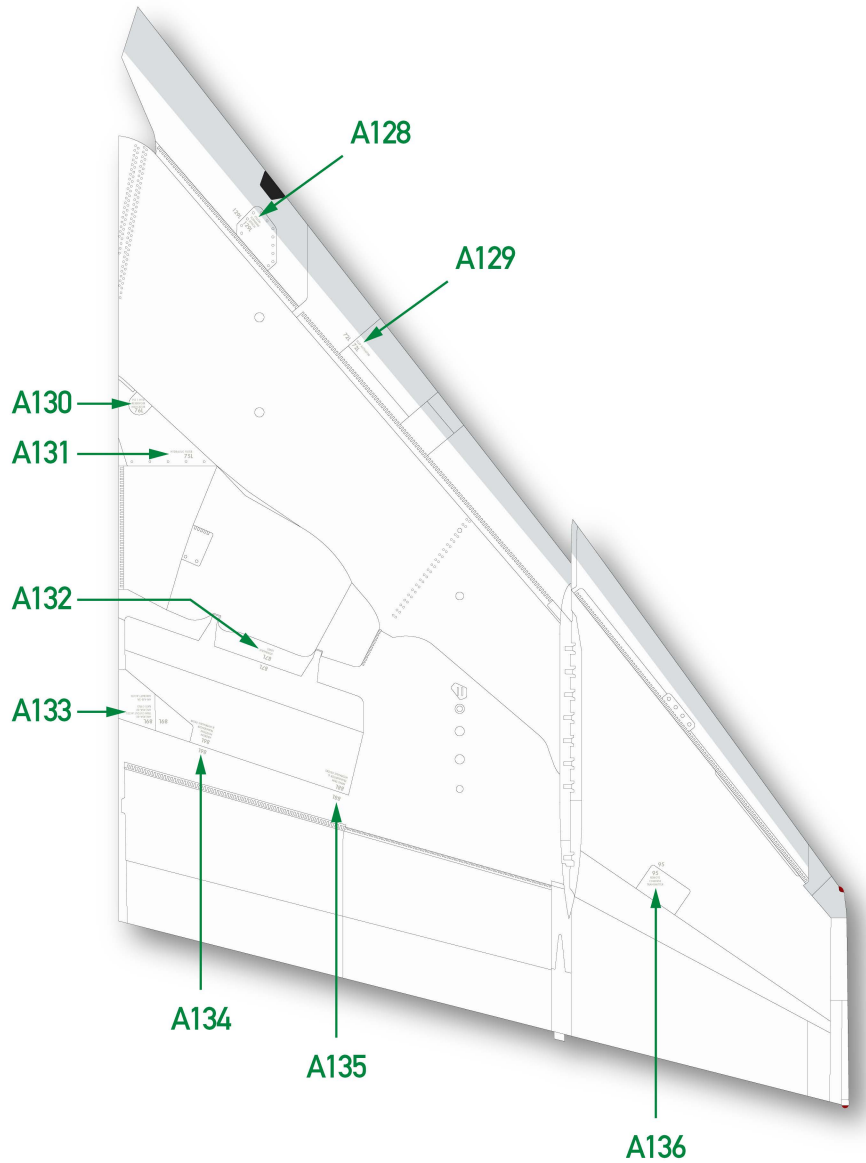

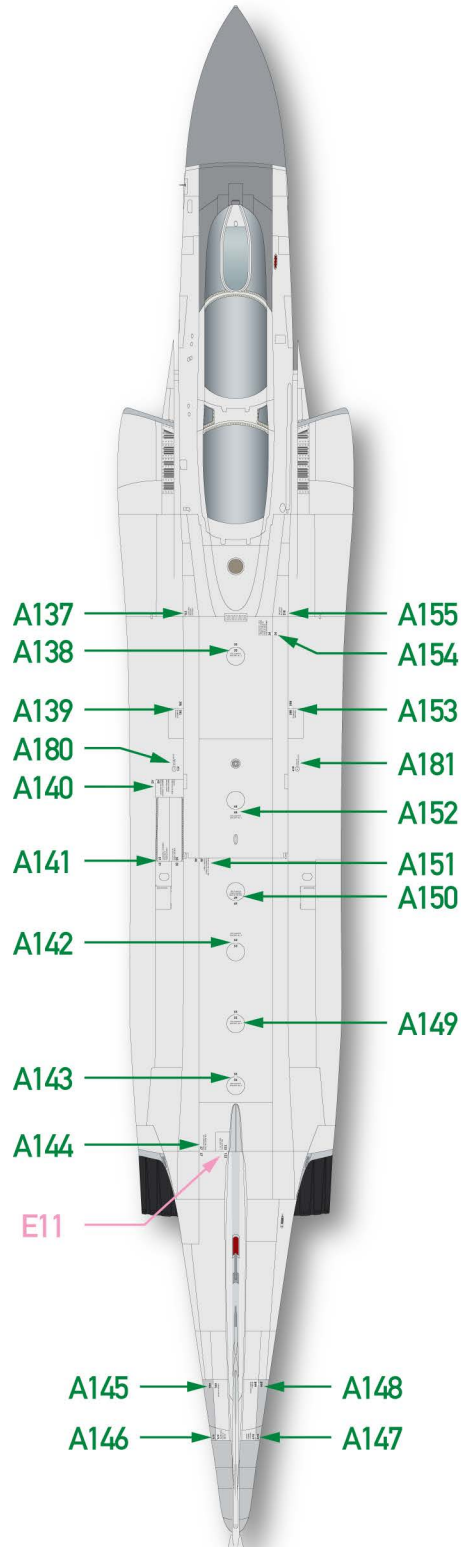

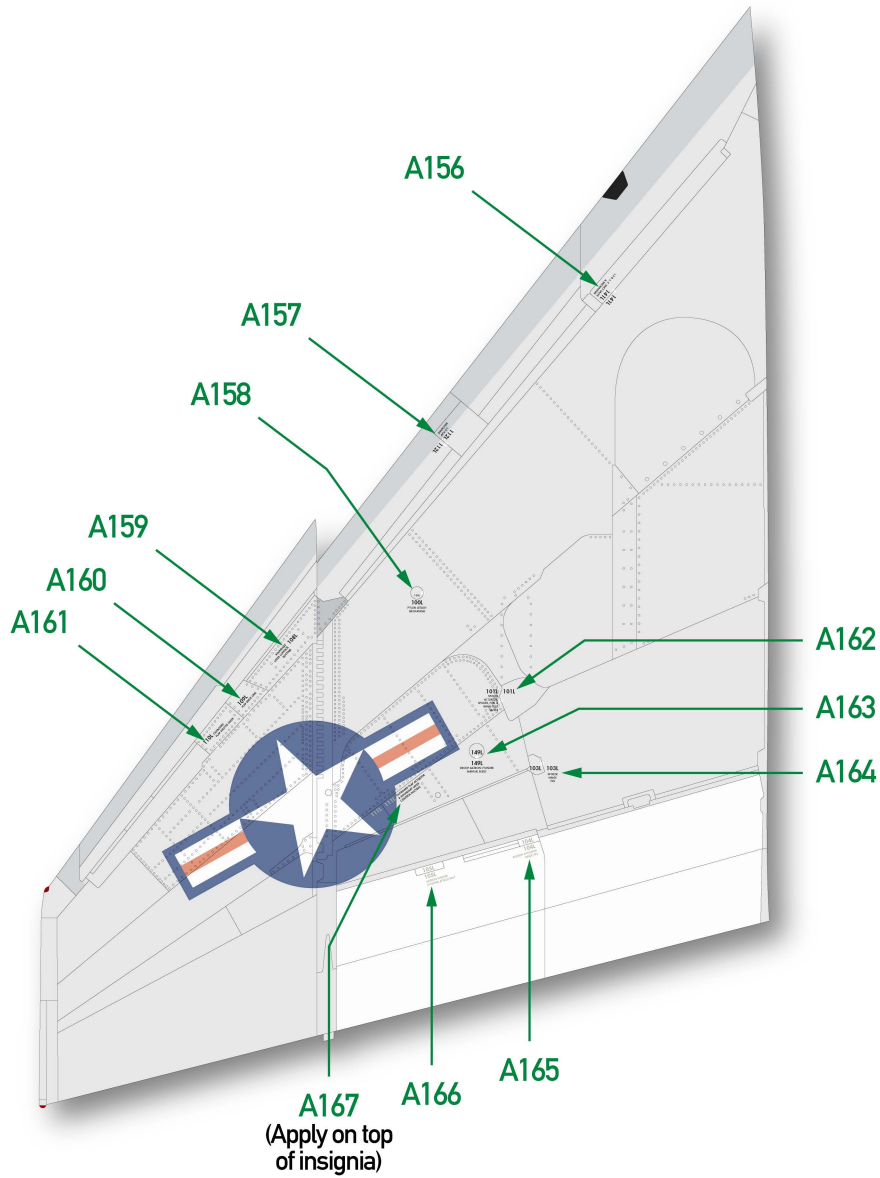

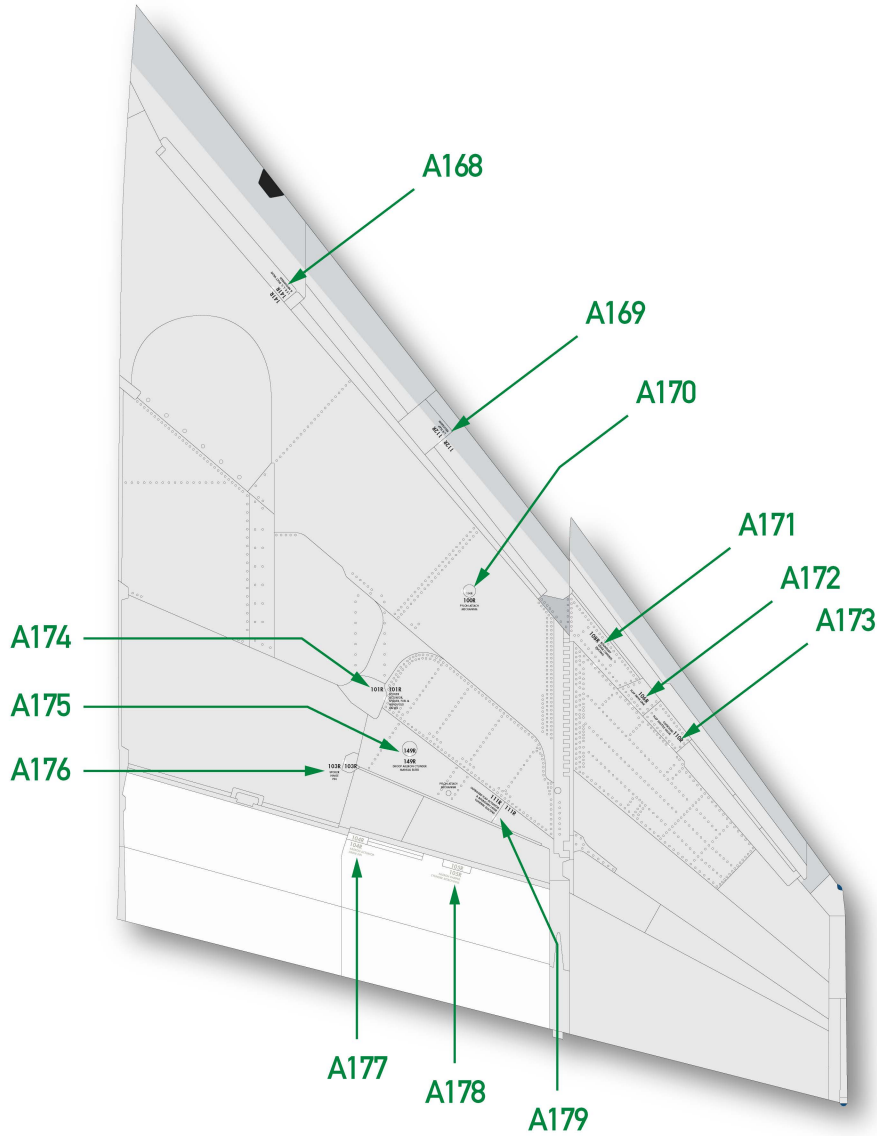

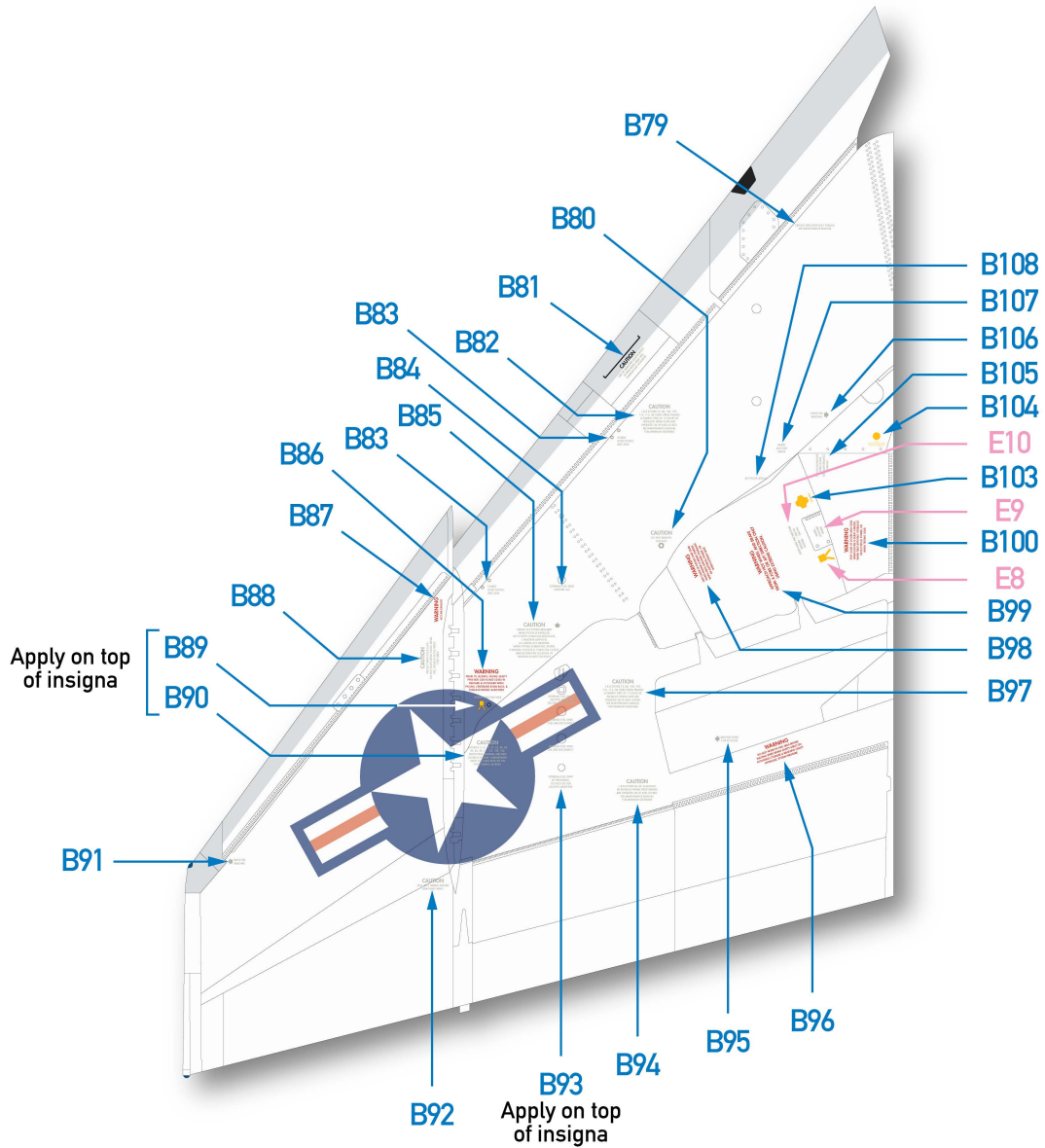

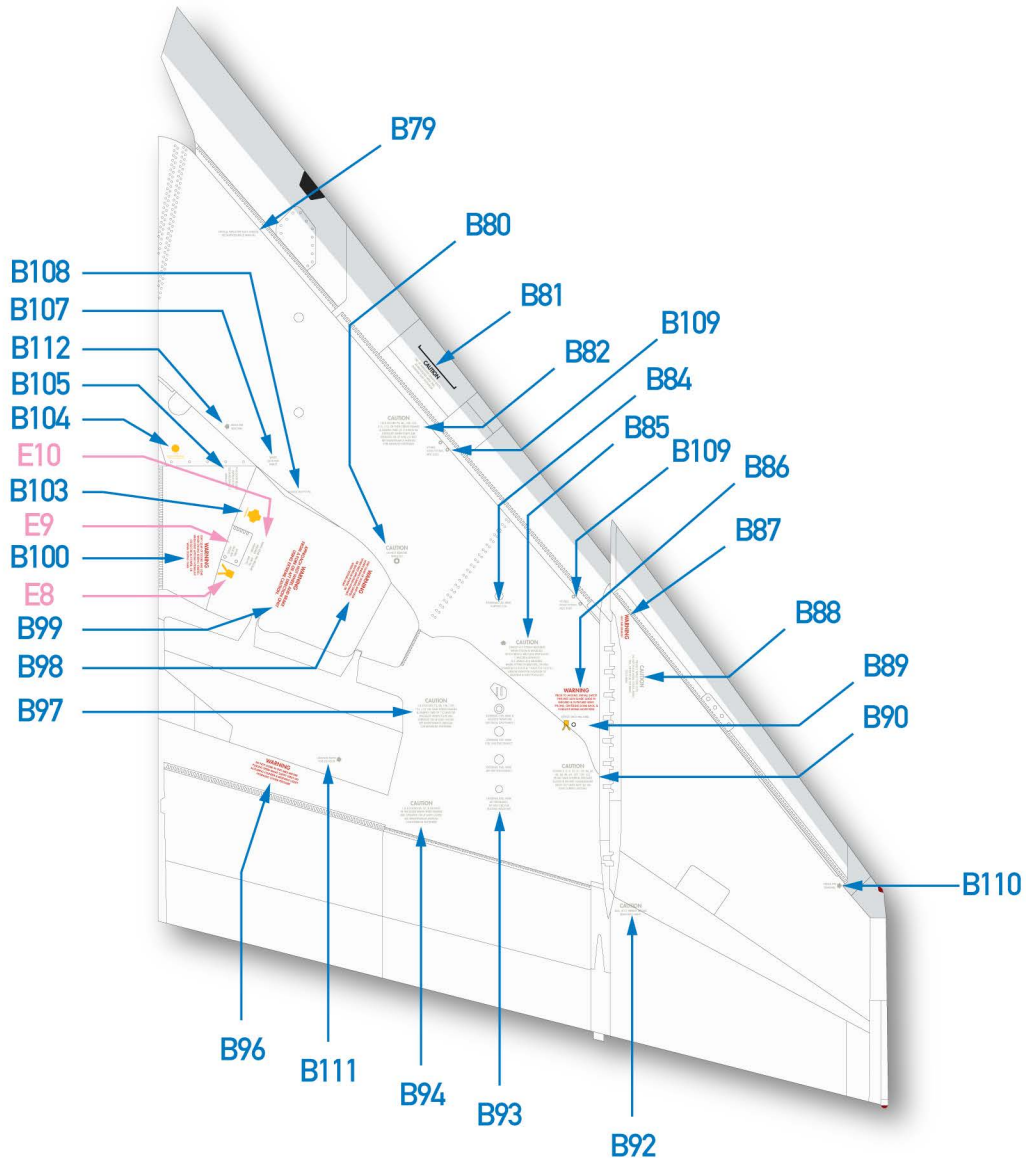

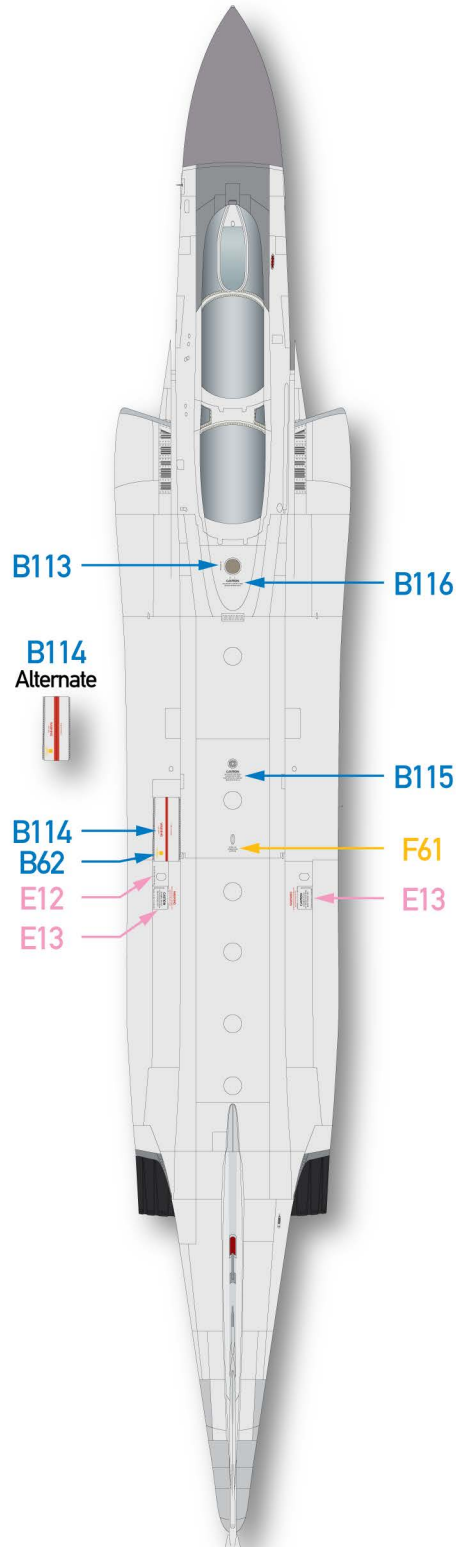

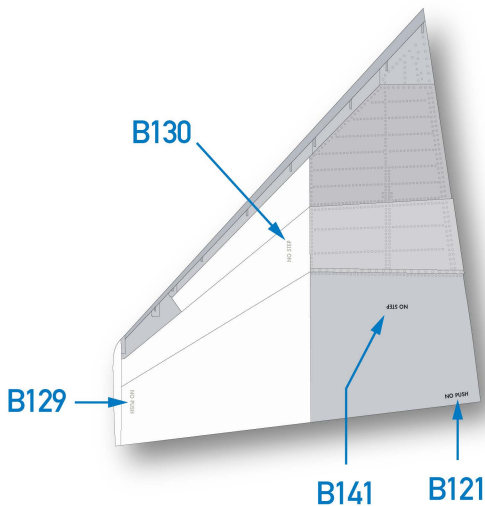
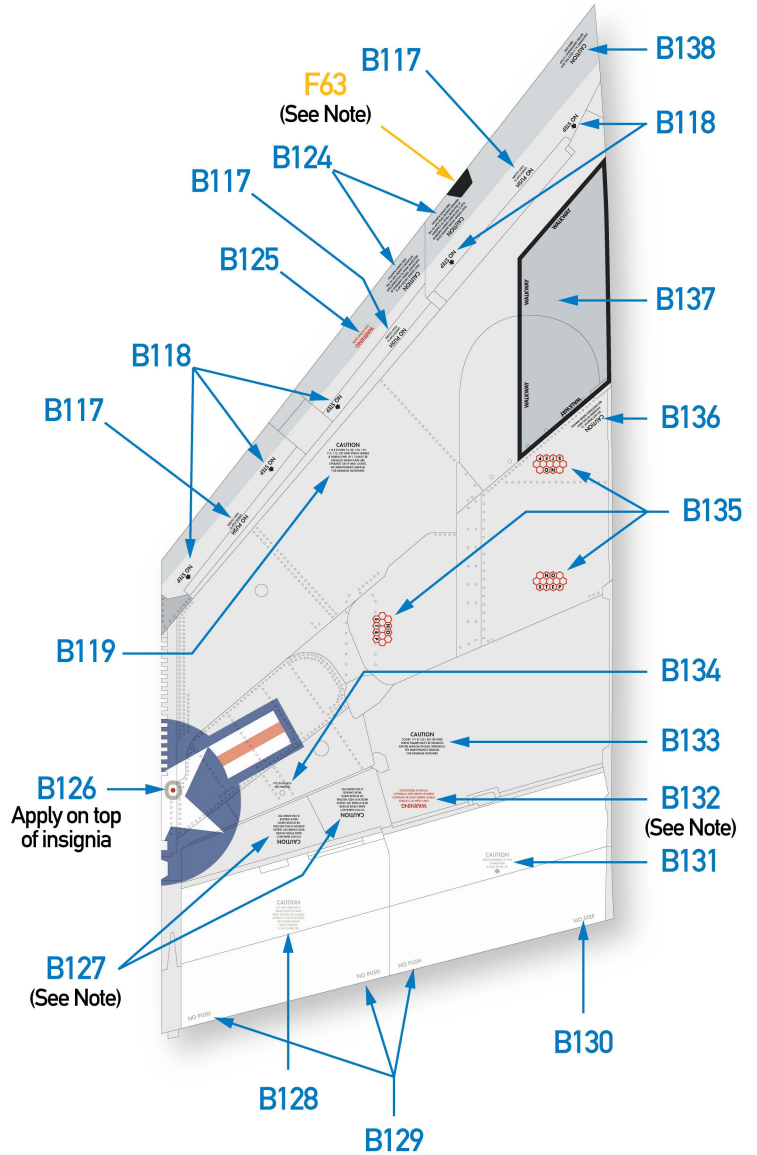
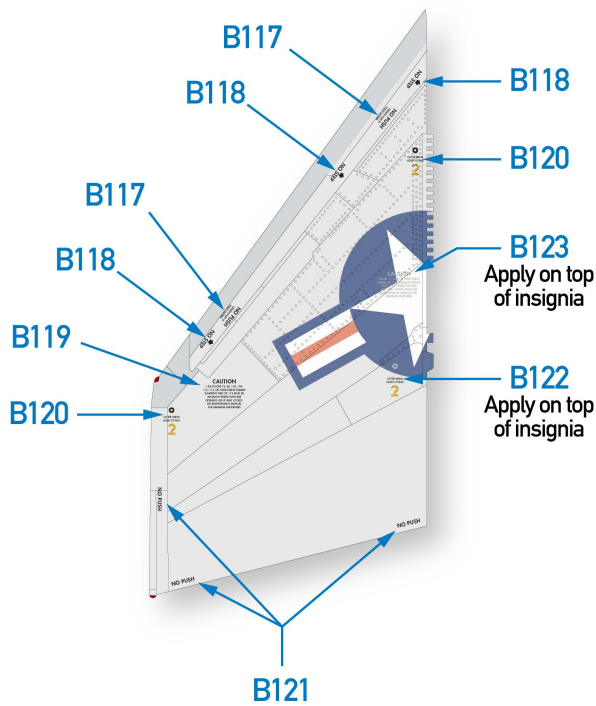

Note:

B127/B132: Note the orientation of these items. Tops of letters face the trailing edge of the wing.

F63/F64: Note orientation of these items. Only found on hard wing F-4Es and F-4Js. Retained even after slats were retrofitted, though sometimes overpainted on F-4S conversions.

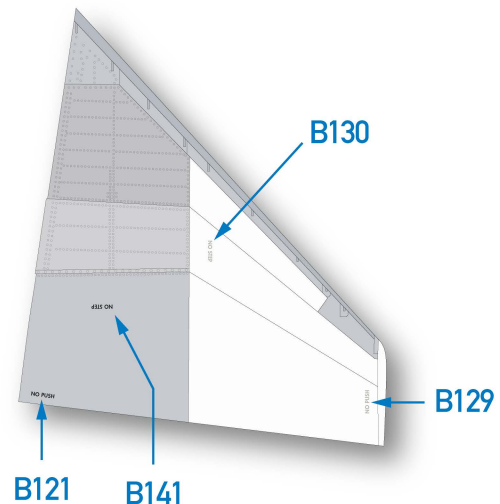
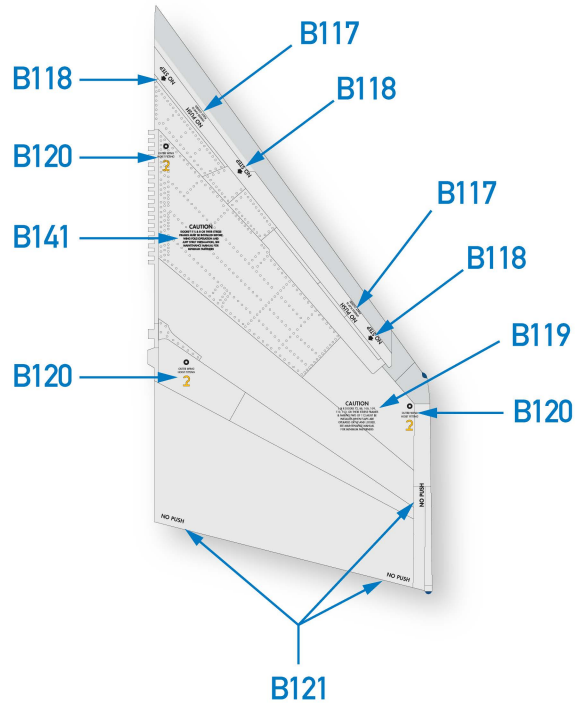
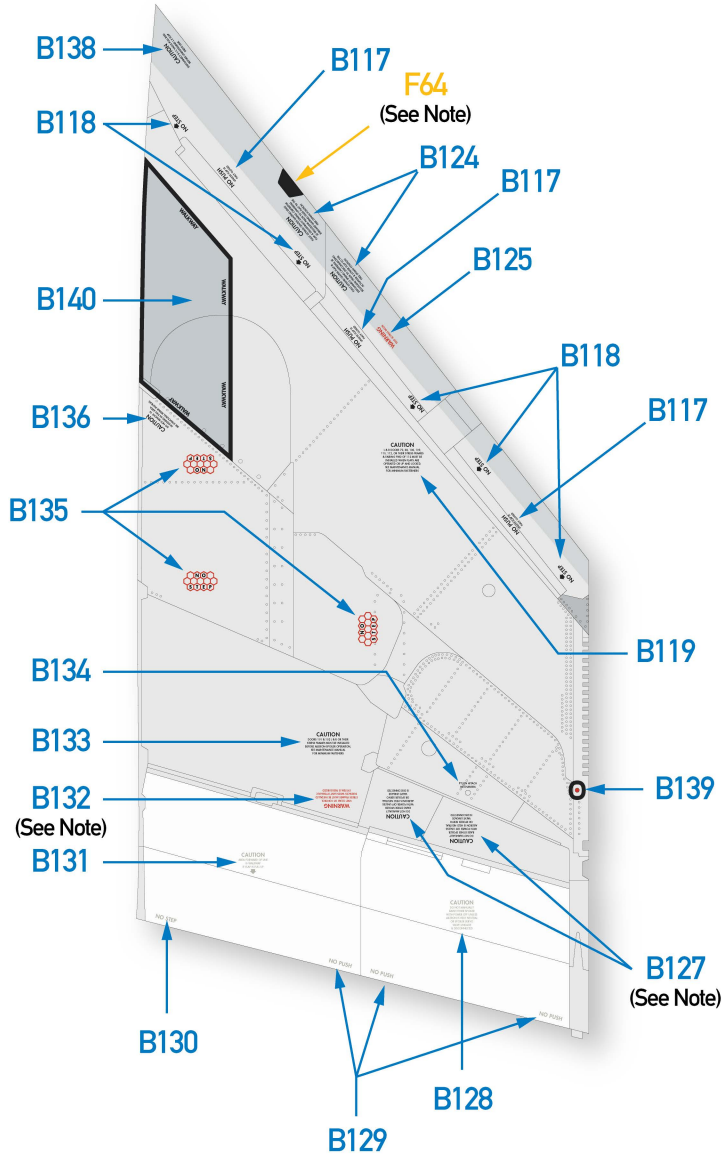

Note:

B127/B132: Note the orientation of these items. Tops of letters face the trailing edge of the wing.

F63/F64: Note orientation of these items. Only found on hard wing F-4Es and F-4Js. Retained even after slats were retrofitted, though sometimes overpainted on F-4S conversions.