

**RESKIT**[™]
RESIN PARTS
FOR SCALE PLASTIC KITS

YOU CAN FIND INSTRUCTIONS
IN PDF FORMAT ON THE WEBSITE

INSTRUCTION **RSU48-0201**

F-111F COCKPIT LATE MODIFICATION WITH 3D DECALS

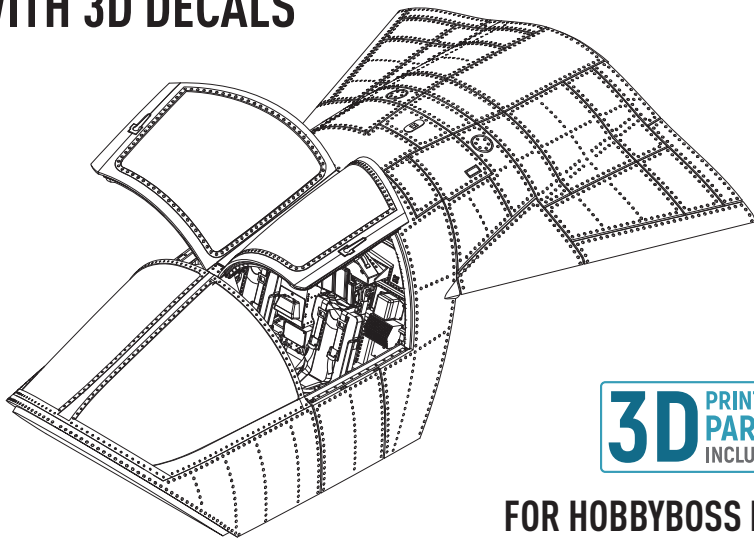

3D PRINTED
PARTS
INCLUDED

FOR HOBBYBOSS KIT

CUT

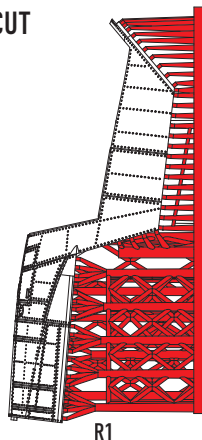

R2

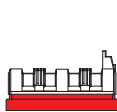

R3*



R4

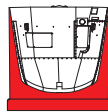

R5



R6

R7

R8

R9

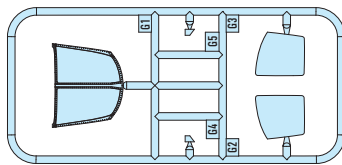

R10



R11

R12

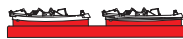

R28

R29

* AFTER REMOVING THE STAND FROM THE PART R3, SHARPEN THE PART AT THE ANCHOR POINT TO A THICKNESS OF 0.5 MM. YOU ALSO NEED TO SHARPEN THE PART A17 FROM THE HOBBYBOSS SET

R15

R16

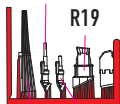

R13

R17

LEFT VIEW



R18

R14

RIGHT VIEW

3D PRINTED PARTS**

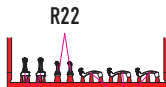

R21

R23

LEFT VIEW



R25

R27

RIGHT VIEW

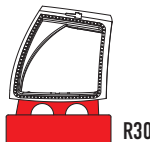

R30

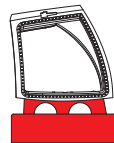

R31

** USE A RAZORBLADE SAW ONLY TO SEPARATE THE STAND FROM THE 3D PART!

3D DECALS INSTRUCTION

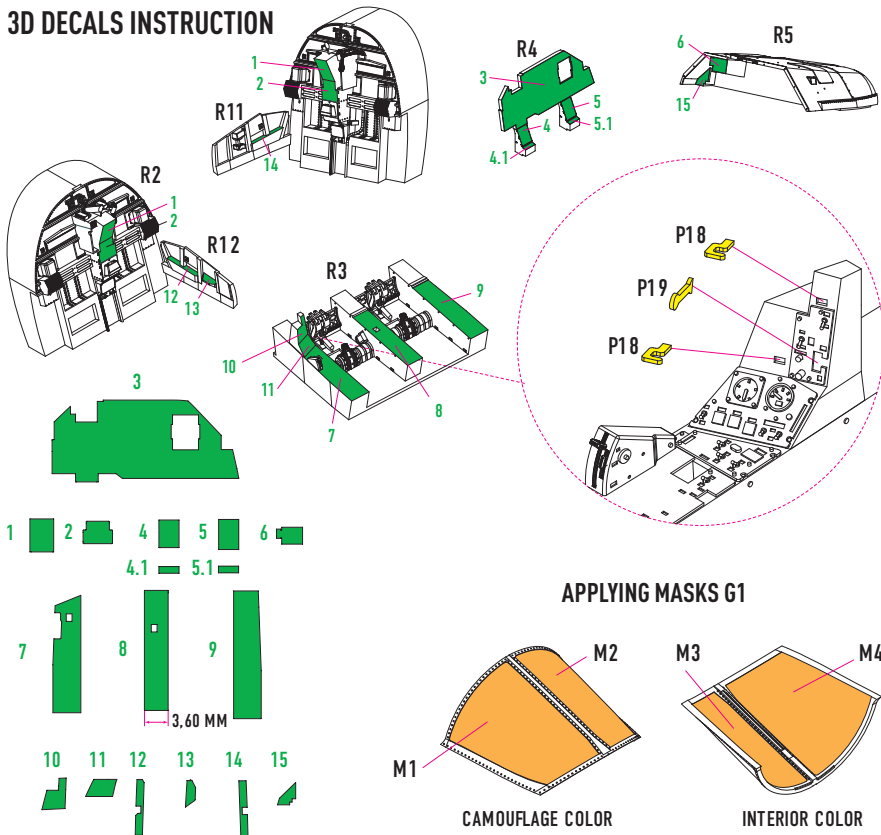

1 X2

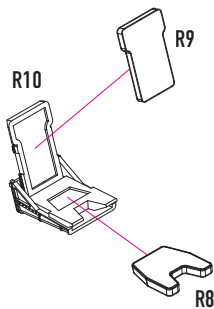

2 X2

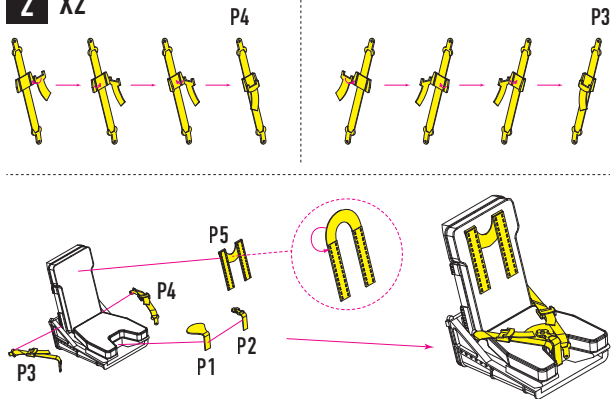

3

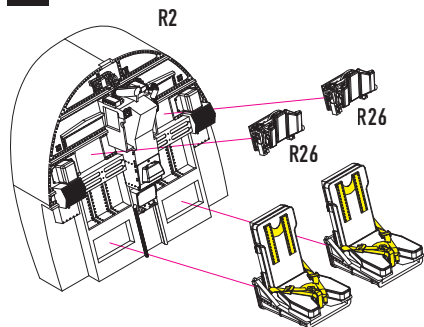

4

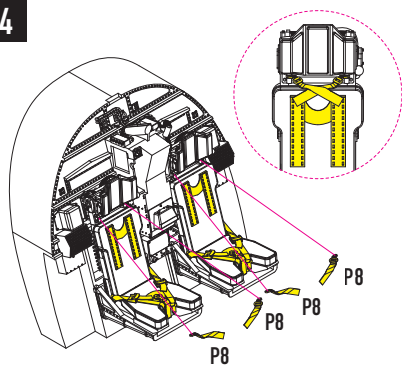

5

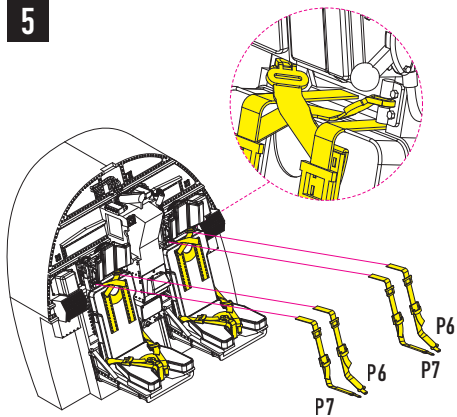

6

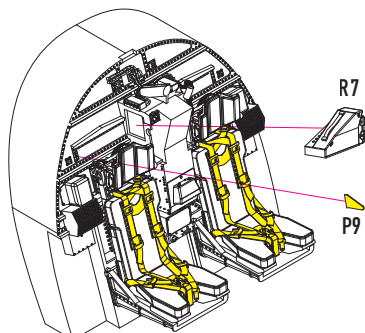

7

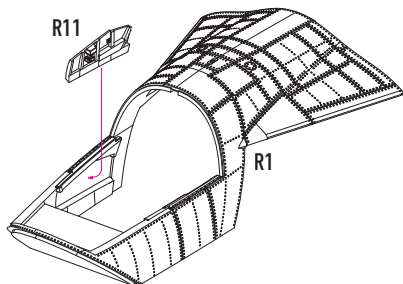

8

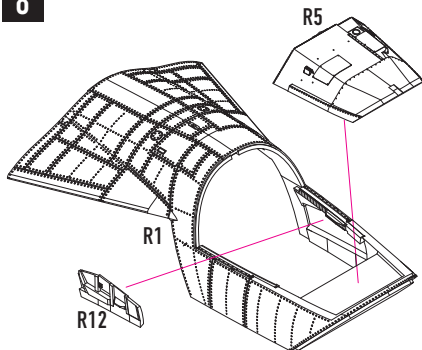

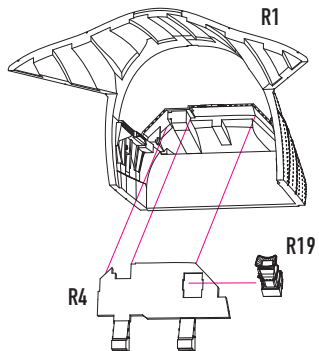
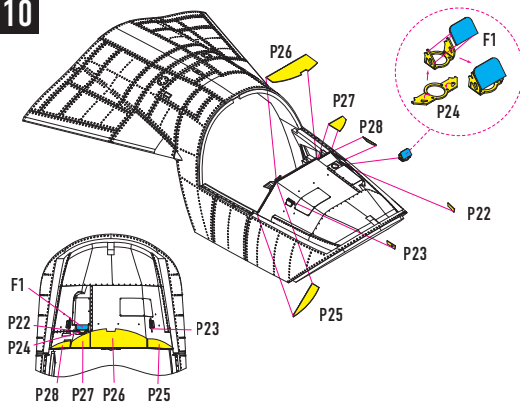
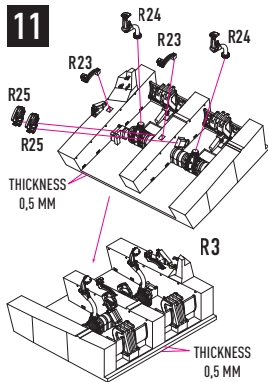
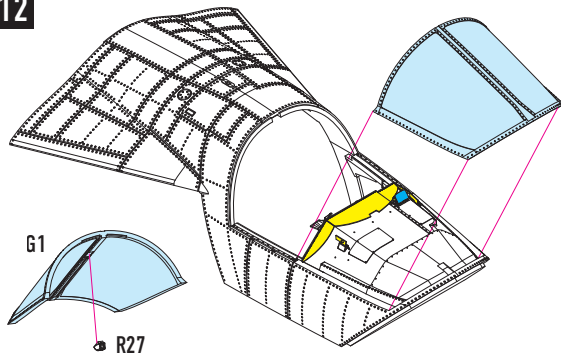
9**10****11****12**

13

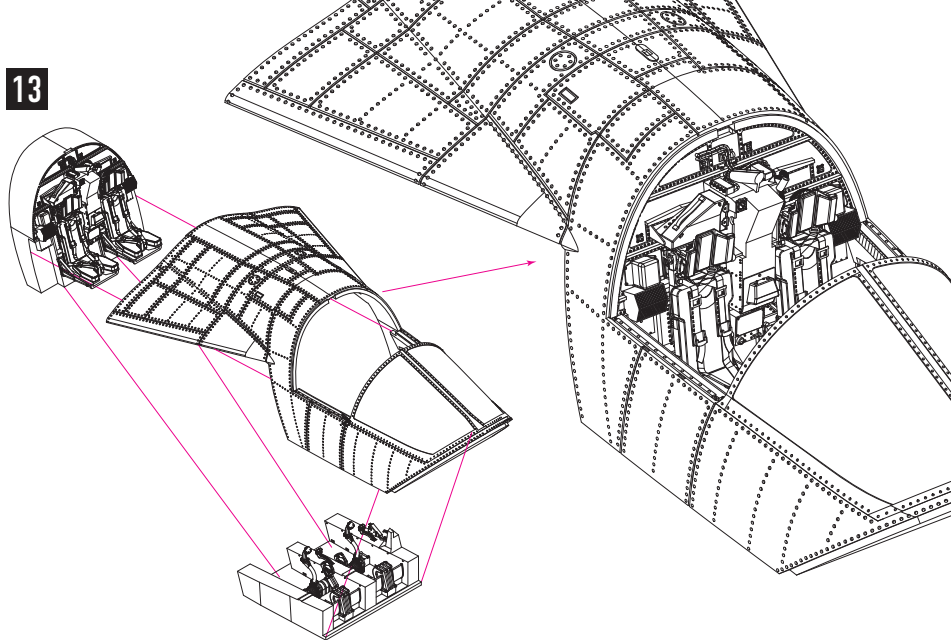

* AFTER REMOVING THE STAND FROM THE PART R3, SHARPEN THE PART AT THE ANCHOR POINT TO A THICKNESS OF 0.5 MM. YOU ALSO NEED TO SHARPEN THE PART A17* FROM THE HOBBYBOSS SET

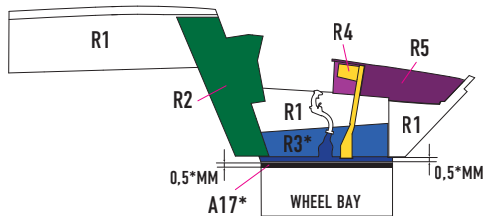

14 FOR CLOSED CANOPY

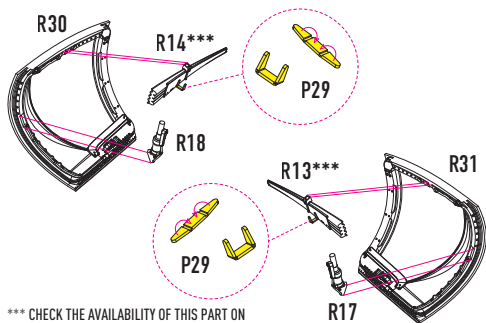

*** CHECK THE AVAILABILITY OF THIS PART ON THE PHOTOS OF THE AIRCRAFT YOU ARE BUILDING

15

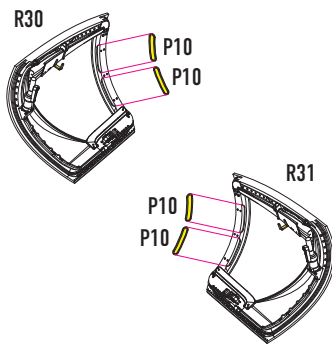

16

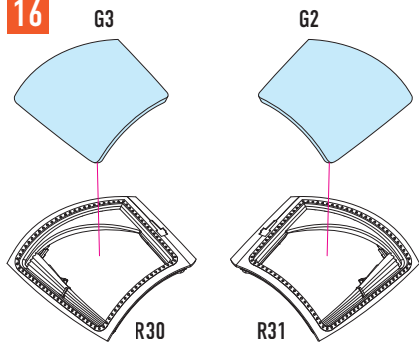

17

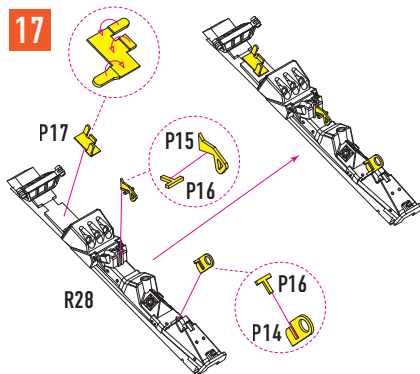

18

R30

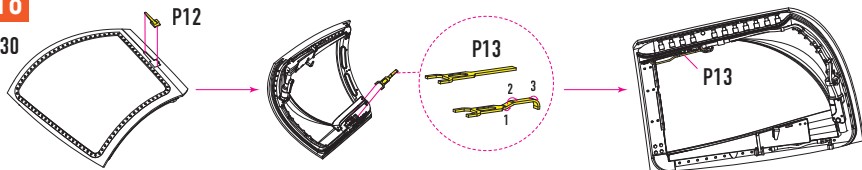

P11

R31

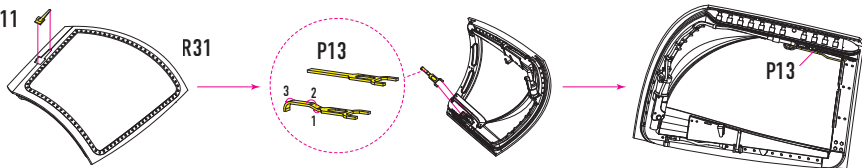
**19**

STEP 17

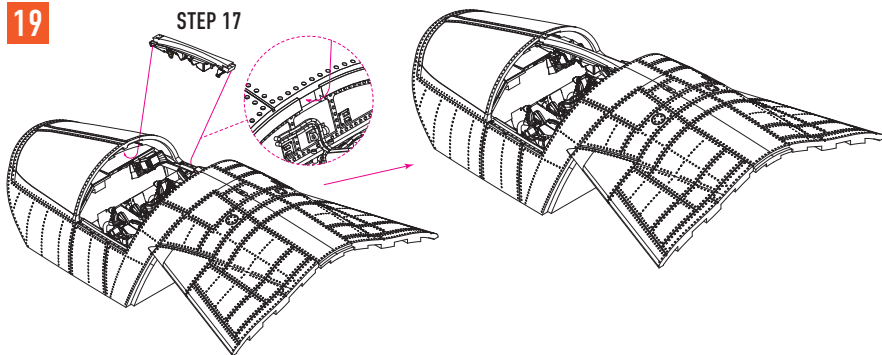

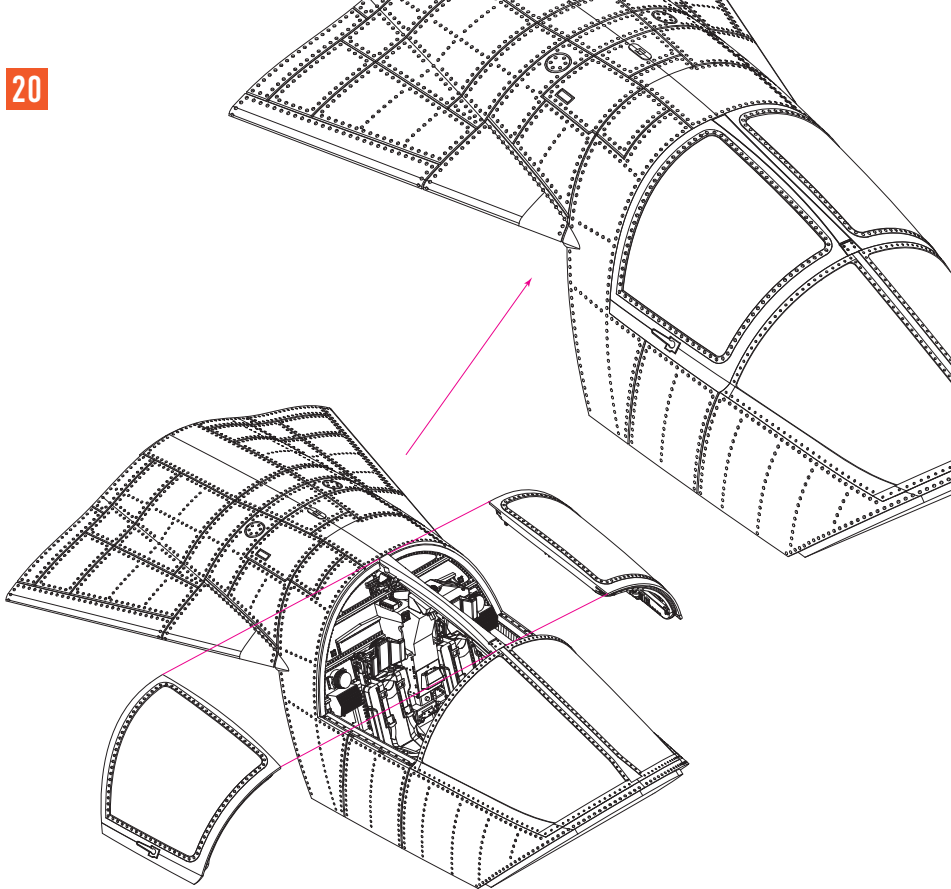

14 FOR OPEN CANOPY

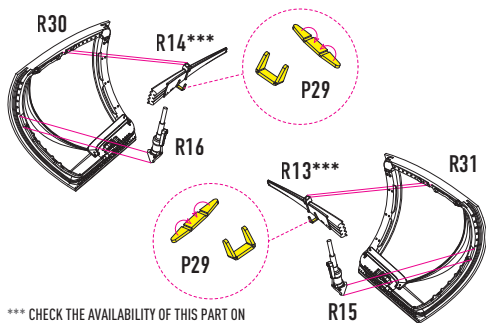

*** CHECK THE AVAILABILITY OF THIS PART ON THE PHOTOS OF THE AIRCRAFT YOU ARE BUILDING

15

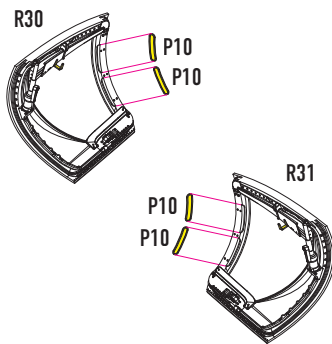

16

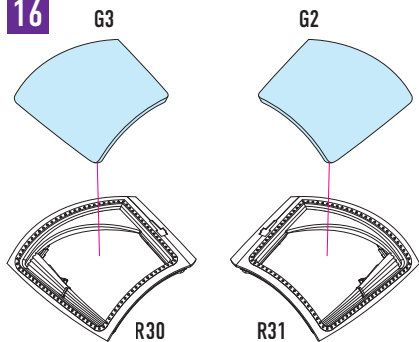

17

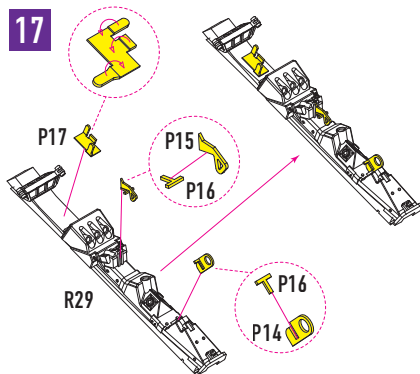

18

R30

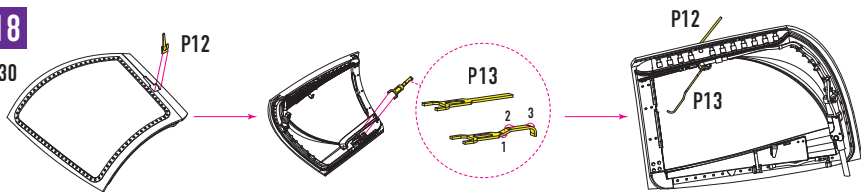

P11

R31

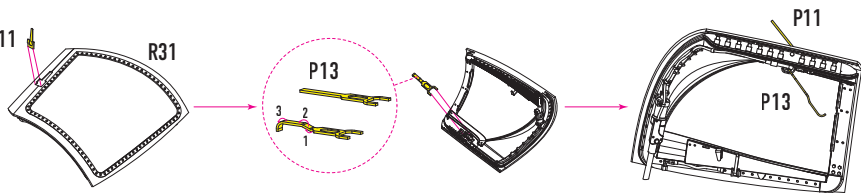
**19**

P21

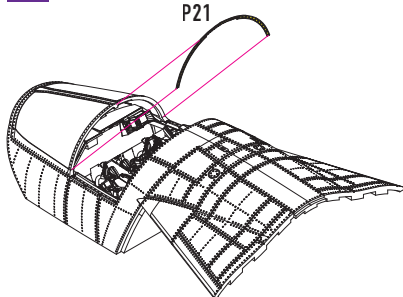
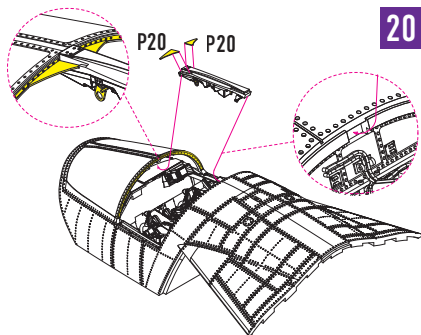
**20**

BEFORE GLUING MAKE THE FLEXION OF THE P20 PARTS
EQUAL TO THE FLEXION OF THE G1 PART EDGE.

21

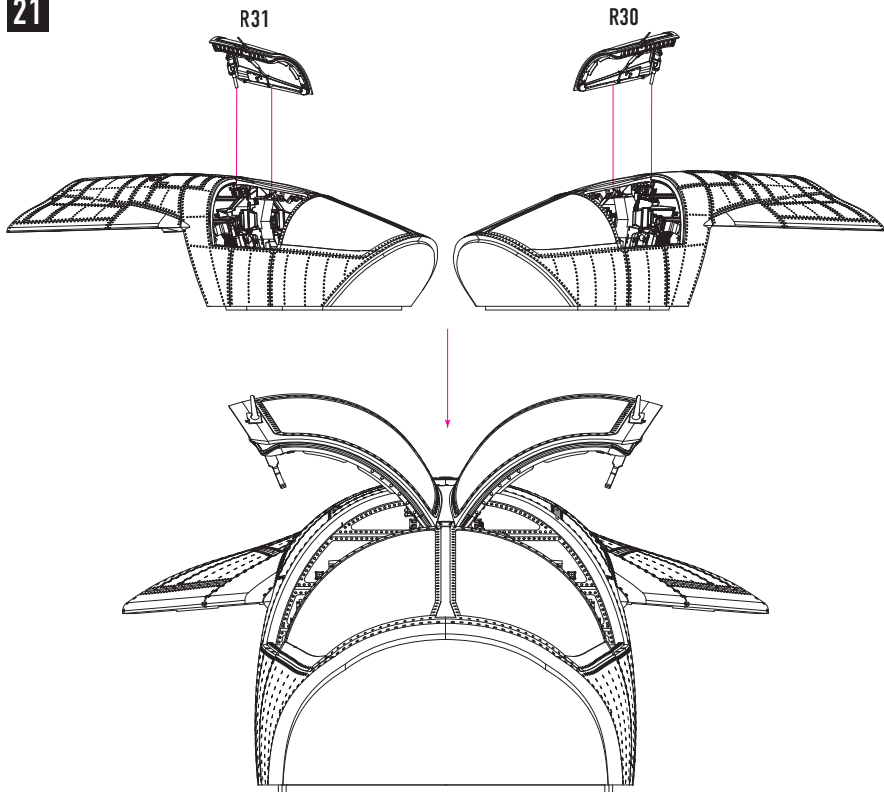

USE WIRE D: 0.3MM, L: 5MM

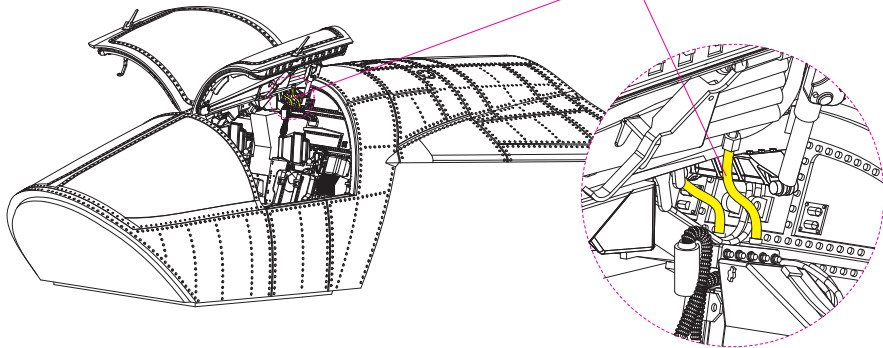

USE WIRE D: 0.3MM, L: 5MM

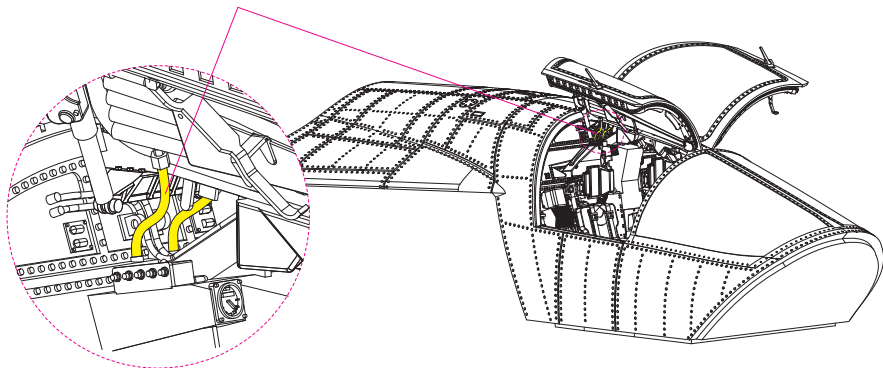

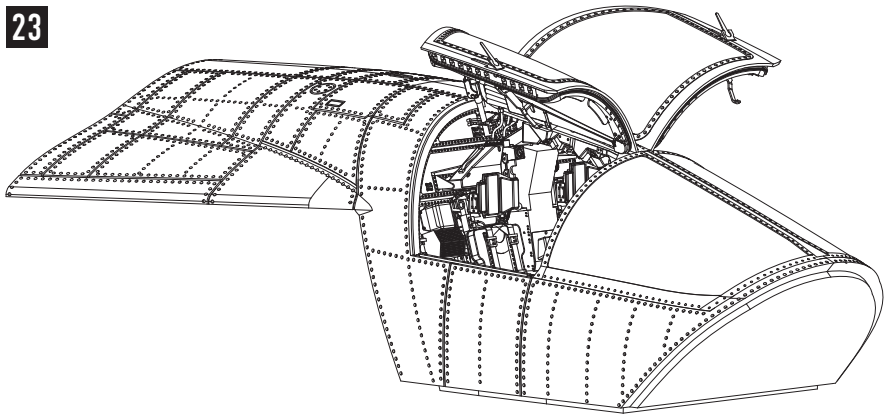

PE INSTRUCTION

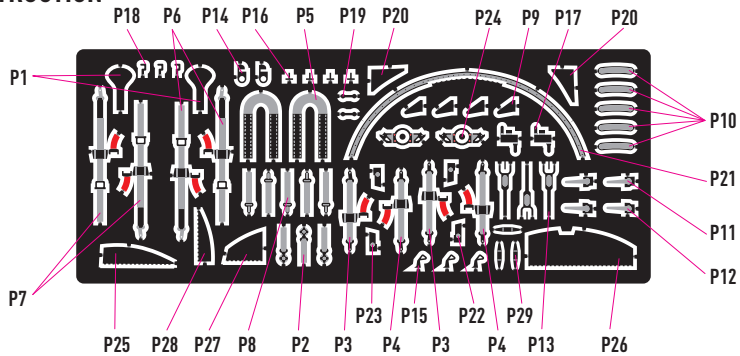

YOU CAN FIND INSTRUCTIONS
IN PDF FORMAT ON THE WEBSITE

RESKIT-MODELS.COM

General Issues: info@reskit.com.ua

Wholesales: sales@reskit.com.ua

Claim Resolution: claims@reskit.com.ua