

CUT

USE A SAW TO REMOVE SUPPORTS FROM 3D PRINTED PARTS

TUBE: D= 0.3 MM, L= 40 MM

REMOVE PROTECTIVE COVER



R1

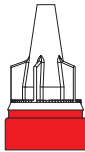
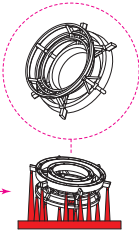

R2

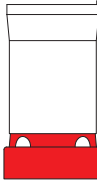

R3

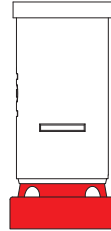

R4

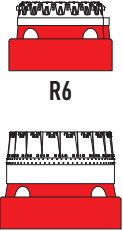

R5

R6

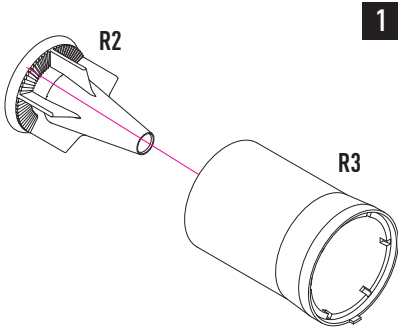

1

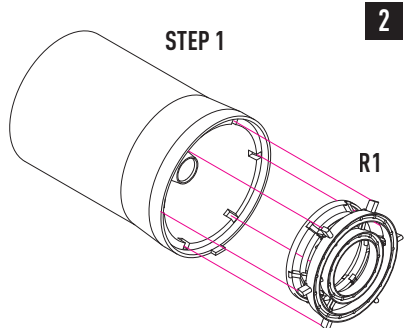

2

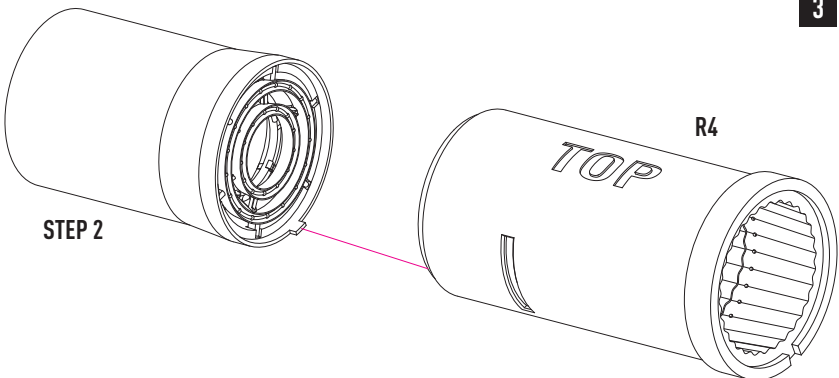

3

