

### CUT

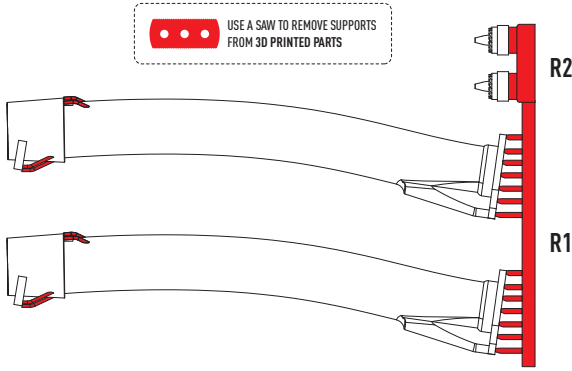

### 1 REMOVE PART C31 FROM KINETIC KIT

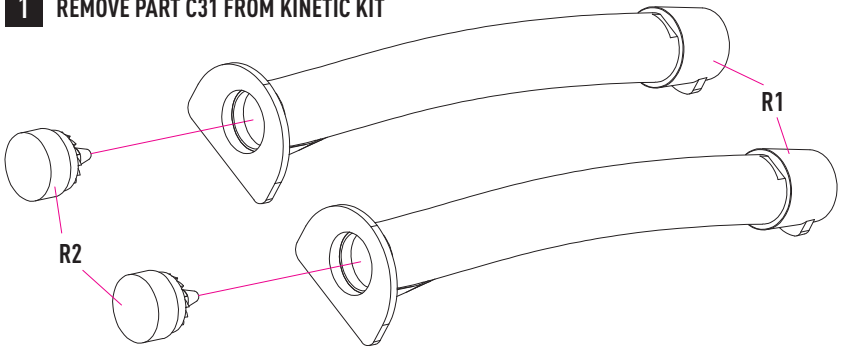

### 2 MAKE A 45° CHAMFER ON THE ENDS OF THE C3 PARTS FROM THE KINETIC KIT

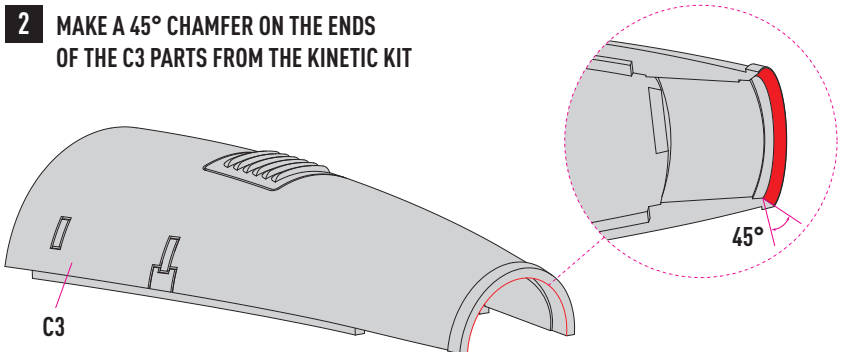

**3 REMOVE FROM PARTS B5 AND B23 IN KINETIC KIT**

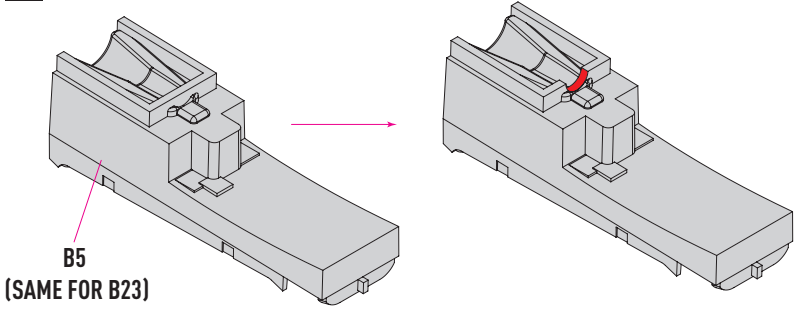

**4 REMOVE FROM PARTS B7 AND B18 IN KINETIC KIT**

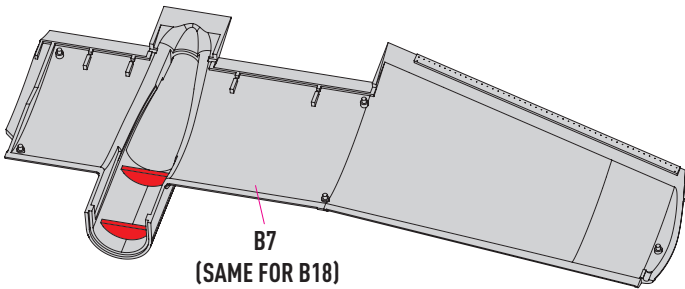

**5**

