

CUT

 USE A SAW TO REMOVE SUPPORTS
FROM 3D PRINTED PARTS

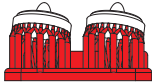

R4

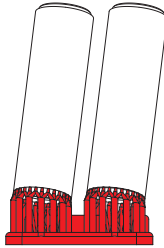

R3 X2

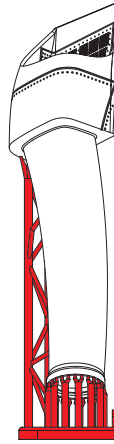

R1

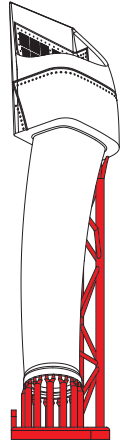

R2

REMOVE PARTS P9, P10, G1, G2, P19, P20 FROM AFV CLUB KIT

1

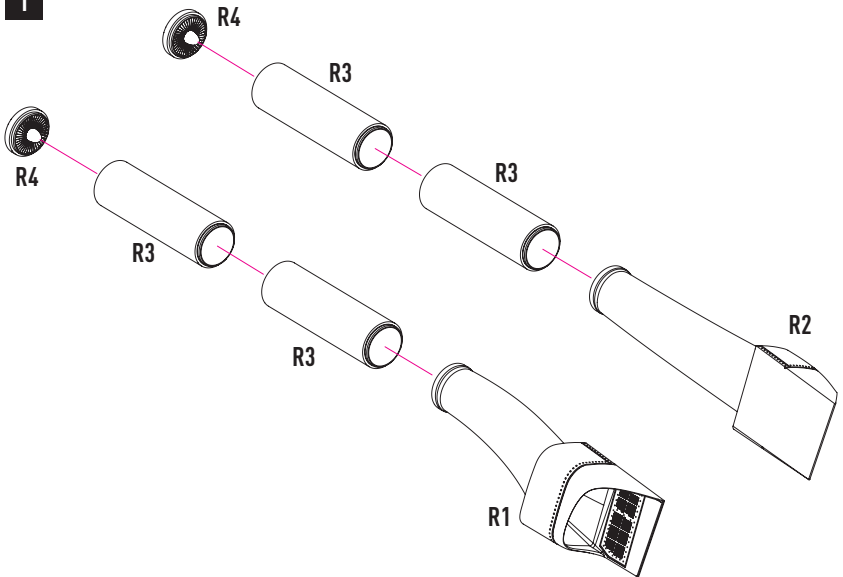

2

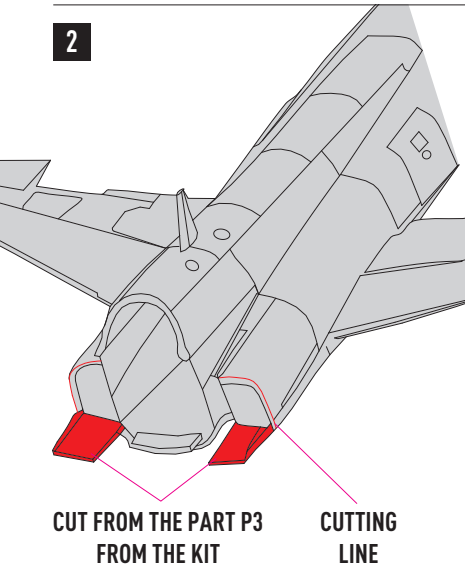

3

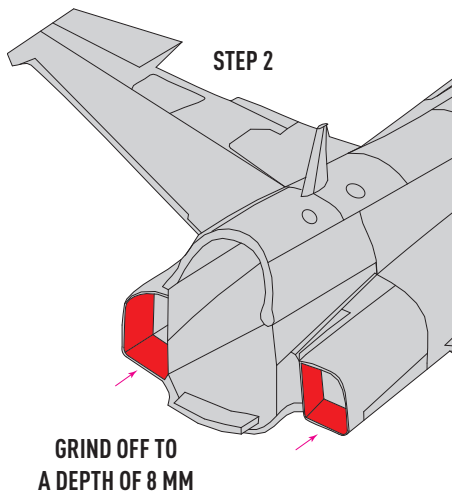

4

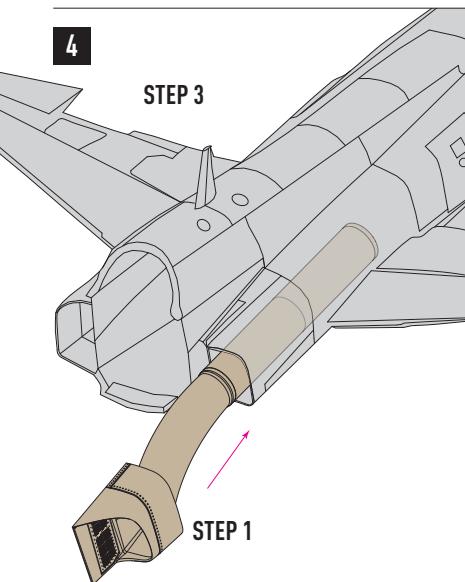

5

