

eduard

ZERO ZE! RO! ZERO

A6M2 Zero Type 21
1941-1944



LIMITED

1/48

INSTRUCTION SHEET

11158-NAV1

A6M2 Zero Type 21

1941-1944

by Jan Bobek



Pilots in their Zeroes prepare for action at Buin Airfield, Bougainville Island in April 1943 during Operation "I-gō". In the foreground are Type 21s from the aircraft carrier Zuihō. The field applied green paint varied from unit to unit.

photo: San Diego Air and Space Museum

The Mitsubishi Zero became the symbol of the Japanese air power during WWII. The nimble and agile fighter had the upper hand over US aircraft at early stages of the war in Pacific theatre, but gradually lost its advantage against newer opponents. During the war, other versions of the Zero came along, but the Type 21, the main fighter plane used by the Imperial Japanese Navy at the beginning of war in the Pacific, remained in combat service until the end of hostilities.

During the 1920s and 1930s the Japanese aircraft industry was oriented towards the production of foreign aircraft built under licenses. However, the armed forces, especially the Navy, with regard to the specifics of the Chinese and Pacific battlefields, came up with requirements that foreign aircraft designs did not offer. Hence, Mitsubishi Heavy Industries developed the Type 96 naval fighter aircraft, better known as the A5M „Claude“. The head of the design team was a young Japanese engineer, Jirō Horikoshi. With an engine that lacked some power, he managed to design a light and fast fighter with a fixed landing gear, which had no comparison in the world regarding maximum speed. In October 1937, Mitsubishi and Nakajima were approached to develop prototype 12-shi Carrier-based Fighter. The requirements were so extreme, and in some cases contradictory, that the two design teams investigated whether they could be less stringent. Nakajima eventually withdrew from the project, while the criteria for the prototype were even raised based on experience on the Chinese battlefield. In the end, Horikoshi's team managed to meet the technical specifications, not only thanks to the aerodynamic design and a new type of light alloy used for the aircraft's skin, but also thanks to the Nakajima Sakae 11 engine. During the flight tests, the wing surface suffered cracking during overload, and aileron control during high-speed maneuvers had also to be addressed. The new fighter had a powerful armament of two cannons and two machine guns, extremely long range (over 1,800 km) and excellent maneuverability. The new fighter reached top speed of 533 km/h at an altitude of 4,550 m. However, it lacked armor and other protective features and had a structural speed limit of 600 km/h.

Surprising Zero

The new aircraft entered service in 1940 with the 940hp engine Sakae 12 and received the official designation Rei shiki Kanjō sentōki (Type 0 carrier fighter), with the „zero“ being derived from the imperial year 2600 (1940). Japanese pilots usually abbreviated it as „Rei-Sen“. That was also the origin of the name „Zero“ often used by Allied pilots instead of the official code name, derived from the male name „Zeke“. As part of the Navy's system, the new machine was given the type designation A6M, where A6 meant that it was the sixth type of carrier fighter to enter service, and M stood for the Mitsubishi company name. Zeros, specifically the A6M2 Type 11, had been successfully deployed on the Chinese

battlefield since the summer of 1940, but their existence eluded Western intelligence because no one wanted to believe reports from China that suggested the Japanese had a world-class fighter. Further modifications to its design were made during 1941, creating the A6M2 Type 21. There were several changes, the most visible of them being folding wing tips for easier handling on the decks. With the A6M2 Type 21 modified this way, Japan entered the war against the US and other Western nations. Mitsubishi needed to produce other aircraft in addition to the Zero, so the Nakajima company also began licensed production in late 1941. Total of 740 A6M2 aircraft were produced by Mitsubishi by June 1942 with additional 800 delivered by Nakajima by February 1944. The gun armament was improved and variants with magazines for up to 150 rounds could be used on the Type 21. Such a Zero may have been designated as Type 21a.

The Nakajima company produced 254 A6M2-N „Rufe“ float plane fighters from December 1941 to July 1943. Its prototype flew on December 8, 1941, and the design featured a pylon with a central float, a solution not used in any country up to that time. The A6M2-N fighters were mainly used to defend naval bases. Several hundred aircraft were also modified from the A6M2 Zero Type 21 and A6M5 Type 52 to the two-seaters A6M2-K and A6M5-K, produced from January 1943 and May 1944 respectively.

Beginning of the Pacific War

Thanks to the experience gained during the war in China, Japan was able to prepare for a large-scale attack in Indochina, the Philippines and against the American fleet at Hawaii. One of the objectives of the southward campaign was even to land in Australia.

The core of the Striking Force, which was to attack Pearl Harbor, were six aircraft carriers divided into three divisions: 1. Kōkū Sentai with the Akagi and the Kaga, 2. Kōkū Sentai with the Soryū and the Hiryū and 5. Kōkū Sentai with the Shōkaku and the Zuikaku. They belonged to the so-called Kidō Butai (Mobile Force) commanded by Vice-Admiral Chūichi Nagumo. He was also the commander of the 1st Kōkū Kantai (Air Fleet), under which the air units aboard the six aircraft carriers were organized. Such a large carrier group had never been deployed in combat in the history of naval operations. Two of the ships, Shōkaku and Zuikaku, were completed just a few months before.

In total 350 machines, out of the 414 available, attacked Hawaii. In the first wave only three Zeros, one D3A and five B5N bombers were lost. In the second wave, six Zeros and fourteen D3As were lost. A total of 74 aircraft returned with damage. Hundreds of American aircraft were destroyed in the raid, but the Japanese left many fuel storage facilities virtually untouched. Of the 79 fighter pilots who took part in both attack waves, only 17 lived to see the end of the war.

The newly organized 3rd and Tainan Kōkūtai with bases in Taiwan were designated to attack the Philippines and Indonesia with A6M2 fighters. Their core was made up of veterans of the disbanded 12th Kōkūtai, which had undergone deployment with the Zeros in China. For the Malayan campaign, a fighter unit was temporarily formed in French Indochina within the 22nd Kōkū-sentai (Air Flotilla), which borrowed airplanes and also personnel from the 3rd Kōkūtai and Tainan Kōkūtai. In this context, the first undamaged Zero (see marking A) fell into enemy hands in November 1941.

During raids on the Philippines on December 8 and 10, 1941, the Japanese naval air force claimed the destruction of about 140 aircraft on the ground and the shooting down of nearly 70 machines in the air. The actual losses of the U.S. and Philippine Air Forces, though less, were still severe. The Zero pilots first encountered four-engine B-17 bombers, which they found very difficult to fight. Thanks to rapid advance of ground forces, both Kōkūtais operating Zeros had bases in the Philippines in late December, and as a result they engaged Dutch airmen over Borneo for the first time.

During the Malaysia campaign in mid-December Zero pilots of 22. Kōkū-sentai joined the fight for Singapore and by the end of the campaign they had 40 victories for the loss of two planes. Later, fighter squadron of 22. Kōkū-sentai briefly operated in Java, Burma, the Indian Ocean area as well as Thailand. Eventually it was taken over by Kanoya Kōkūtai. During February 1942, intense fighting over Java was experienced primarily by the 3rd and Tainan Kōkūtai. Their airmen claimed over 100 victories with the actual loss of only about 10 of their own. At the end of the month, some fighters participated in escorting the bombers that sank the former aircraft carrier USS Langley, converted to a seaplane tender. Zero pilots strafed the deck with dozens of new P-40E fighters stored enroute to Java.

In the early months of the Pacific War, the Americans and their allies realized how much they had underestimated their Japanese adversaries. One of the main symbols of this sobering realization was the Zero fighter, which had developed a reputation as a nearly invincible adversary early in the war.

Aircraft carrier operations till the spring of 1942

While the carriers were returning from the attack on Pearl Harbor, news reached Nagumo that the landing at Wake Atoll had been repulsed and a second attempt required carrier support. The Sōryū and Hiryū air units therefore conducted raids on the island on December 21 to 23, 1941. This was the first time that Wildcats and Zeros were engaged in combat.

During the January 20 to 22, 1942 carriers Akagi and Kaga got into action again, this time in raids on Rabaul and the New Guinea airfields. They met essentially only valiant resistance of few Australian crews with Wirraway aircraft. There was growing discontent among Japanese carrier aviation commanders. Unable to get into engagements with American carriers, Nagumo's airmen felt they were being deployed against targets with low significance.

Air units from the ships Akagi, Kaga, Hiryū and Sōryū attacked Darwin Harbour on February 19 and, with the loss of four aircraft, caused what is known as Australia's Pearl Harbor. After an emergency landing, Seaman 1st Class Hajime Toyoshima of the aircraft carrier Hiryū was captured. He became the first living Zero pilot to end up in enemy hands, although his machine was not in a repairable condition after the crash.

Returning to north, aviators from the ships Akagi and Kaga covered the landing at Tjilatjap, Java, on March 5, sinking eight vessels in the process. Kaga then returned to Japan due to minor hull damage.

At the end of March, a task force which core consisted of Akagi, Shōkaku, Zuikaku, Sōryū, and Hiryū sailed for Ceylon. During April 5 to 9, Japanese airmen claimed shooting down of nearly a hundred RAF aircraft, the destruction of a number of ground targets and the sinking of many vessels, including the aircraft carrier HMS Hermes. In doing so, they faced veterans from Britain, Canada, and other Commonwealth countries. One year ago, some of the Allied airmen had participated in the fight against the German battleship Bismarck. British fighter pilots with Hurricanes were able to use hit-and-run tactics with partial success. This approach, already used by other Allied airmen became winning strategy against Zeros for the rest of the war.

Although the Japanese had feared for some time that the Americans would try to attack targets directly in Japan, Doolittle's raid on April 18, 1942, was a huge surprise. Akagi, Sōryū, and Hiryū were just off Taiwan and headed for Japan. Nagumo changed course to the east on April 19 and tried to chase the attackers. However, the USS Enterprise and Hornet were already out of range. The Japanese carriers gave up the search after several days.

Coral Sea, Aleutians and Midway

The next target of the Japanese command was the port of Port Moresby in the southeast of New Guinea. It was to be a base for the planned landings in Australia. At the same time, the Japanese hoped that their invasion force would attract American aircraft carriers and a decisive battle would occur. The aircraft carrier Shōhō covered the landing on Tulagi Island off Guadalcanal during May 3, 1942. She then joined the vessels bound for Port Moresby. But on May 7 the carrier was attacked and sunk by aircraft from the USS Lexington and Yorktown.

Airmen from Shōkaku and Zuikaku were not able to intervene in the battle until the following day. They reported shooting down 64 Allied aircraft and severely damaging both U.S. carriers in their attack on the American task force. The Lexington had to be sunk later. The American airmen damaged the Shōkaku, and during combat air patrol the Japanese fighters reported 40 victories while losing two Zeros throughout the day. Although the Japanese achieved a tactical advantage in the battle thanks to the sinking of the heavier carrier, they had to cancel the landing at Port Moresby.

The Japanese planned for an early June campaign towards Hawaii, with the target of the forces under Admiral Yamamoto being the American territory on the Aleutians and Midway Atoll. The attack on the Aleutians is often mistakenly described as an operation to divert attention from the attack on Midway. It was, however, one operation conducted in two directions with reserve forces positioned about half the distance between the two task forces. Six carriers participated in the operation, and on board all of them, in addition to their own carrier air units, were Zeros, ground personnel, and pilots of the land based 6th Kōkūtai. This unit was to be based at Midway Atoll after its capture. The fighter pilots of the 6th Kōkūtai participated in both the raids on the Aleutians and the fighting during the Battle of Midway.

Airmen from the carriers Ryūjō and Junyō conducted attacks against Dutch Harbor on the Aleutians during June 3 and 4, 1942, and scored several victories against amphibious aircraft and P-40 fighters. However, one of the Zeros crashed on Akutan Island and despite the efforts of the Japanese, neither the machine nor the pilot could be found. The lost airman was PO1c Todayoshi Koga, whose Zero was found by the Americans a month later and put into airworthy condition (see Marking D). As planned, the Japanese established a floatplane base on the American island of Kiska.

Nagumo's task force with core of fleet carriers Akagi, Kaga, Sōryū and Hiryū launched raids on Midway Atoll on June 4. The Americans, however, were prepared for the attack by deciphering Japanese coded communications. They sailed into battle with the aircraft carriers USS Enterprise, Hornet and Yorktown, the latter urgently repaired after the Battle of the Coral Sea. For the engagements of the first attack wave, the Japanese fighters reported 35 shot down USMC airplanes with the loss of one Zero, shot down by AA fire.

However, the Japanese had inaccurate data from reconnaissance crews about enemy vessels. In the critical part of the battle the Japanese aircraft began to come back to their carriers to change their armament in view of the change of targets from carriers to land targets and back to carriers. The Americans made a large number of attacks on the Japanese fleet with Marine Corps, Army Air Forces and Navy aircraft. Japanese fighters made dozens of launches in defense of their carriers and claimed 90 victories with the loss of 13 of their own aircraft, but their efforts were in vain. American attacks were so intense that the carriers Akagi, Kaga and Sōryū were eventually fatally hit, just as they were replacing armament in their hangars. Deficiencies in the design of Japanese carriers' passive protection and insufficient damage control were fully exposed.

The last vessel able to intervene effectively in the battle was the carrier Hiryū, which sent two waves of bombers against the American carriers. The raids damaged the USS Yorktown so badly that she eventually had to be sunk. Each of the bomber formations was accompanied by six Zeros, whose pilots claimed 18 American aircraft while losing five machines.

The Americans eventually hit Hiryū, which was defended by twelve fighters, who could not prevent fatal consequences. Although her propulsion was not hit, the fires could not be brought under control, and she sank on June 5.

The Japanese suffered a crushing defeat that was the turning point of the war in the Pacific. In addition to the four carriers, they lost the one cruiser and several other vessels were damaged. More than 3,000 crewmen were killed. The loss of 23 fighter pilots who died in combat or aboard their ships was not critical. However, the loss of bomber crews and many members of technical personnel had a significant impact.

New Guinea and Australia

In early February 1942, the 4th Kōkūtai moved into the newly captured Rabaul, using twin-engine bombers and A5M fighters. From the middle of that month, its fighter squadron began taking over the modern A6M2 fighters brought to Rabaul by the aircraft carrier Shōhō. In early March, 4th Kōkūtai Zeros moved to

Lae, New Guinea, and began escorting bombers over Port Moresby and to Horn Island in northern Australia. In early April, the fighter squadron of 4. Kōkūtai was taken over by Tainan Kōkūtai, which moved into the area. In mid-May, Tainan Kōkūtai took over additional 15 Zero fighters and pilots from the 1st and Chitose Kōkūtai. Their opponents were initially mainly Australian airmen and American bomber crews, but later American fighter units also arrived in Port Moresby. Other fighter units with Zeros also operated over eastern New Guinea during 1942. But the main battlefield from the middle of the year became Guadalcanal. Fighting over New Guinea intensified again at the end of 1942 and in 1943, during the Allied advance northward.

Northwestern Australia began to be the target of frequent Japanese naval air raids from February 1942. Zeros appeared regularly over Australia from early March, after 3. Kōkūtai (later redesignated the Kōkūtai 202) stationed at Kupang, Indonesia. Until the autumn of 1943, the Japanese conducted over 200 reconnaissance and bombing sorties over Australia. Because of their long range, the A6M2 Type 21 continued to be used in these missions. Actual recorded losses were close to 1:10 in favor of the Zeros, with their frequent opponents being Spitfires Mk.V. This result was remarkably different compared to the air battles in the Solomon Islands and Rabaul area.

Guadalcanal

The Japanese started building an air base on Guadalcanal in July 1942, posing a serious threat to shipping between the US and Australia. The Americans therefore landed on Guadalcanal on August 7, and were soon able to begin air operations from the occupied Japanese airfield, and from new ones they subsequently built.

In terms of fighter operations, for the first weeks it was main responsibility of Tainan Kōkūtai. During bomber escort flights to Guadalcanal and convoys patrols, pilots flew from Rabaul, a 1065 km distance. The Japanese command gradually deployed other fighter units in the area, primarily the 2nd Kōkūtai, part of the 3rd Kōkūtai, the 6th Kōkūtai and the Kanoya Kōkūtai. In September 1942, the Japanese managed to get the airfields operational on the islands of Buka and Bougainville, which were closer to Guadalcanal.

In mid-1942, a new version of the Zero designated the A6M3 Type 32 began arriving on the battlefield. It was equipped with the more powerful Sakae 21 engine and had a shortened wingspan. However, it was unsuitable for missions over Guadalcanal due to its shorter range. In late 1942, its production was discontinued and replaced by the A6M3 Type 22 from early 1943. Thanks to the modified design of the fuel tanks and wing, which looked similar to the Model 21, the range of this newer version was even extended by 160 km. The Type 21 Zeros, however, continued to be the important armament of IJN fighter units engaged in the Salomon Islands, whether at ground bases or on aircraft carriers.

Two naval engagements occurred during the Battle of Guadalcanal, with aircraft carriers deployed on both sides. The first was the Battle of the Eastern Solomons on August 24 and 25. Simultaneously with the Japanese convoy heading for Guadalcanal, a task force with the aircraft carriers Shōkaku, Zuikaku and Ryūjō headed for the same area. The Japanese had no intelligence on the location of the American carriers and therefore conducted a raid on Henderson Airfield on Guadalcanal. Aircraft from the USS Saratoga succeeded in sinking the Ryūjō and the Japanese later damaged the USS Enterprise. Some Zero fighters from the remaining carriers then briefly operated from ground bases. During October 1942, the Japanese also deployed the carriers Zuihō, Junyō and Hiyō in the Salomon Islands in addition to Shōkaku and Zuikaku. During October 25 to 27, the Battle of the Santa Cruz Islands occurred, in which only Hiyō did not participate. IJN carriers were confronted by the USS Hornet and Enterprise.

American naval aircraft damaged the Zuihō and Shōkaku, but Hornet was lost and Enterprise suffered damage. Although the Japanese achieved a tactical victory, their aircrew losses were higher than in the Battle of the Coral Sea. Therefore, even the carriers that were not damaged had to withdraw from the battlefield. The fighter unit of carrier Hiyō remained in the area. For almost the next two years, this was the last carrier engagement in the Pacific.

In early November 1942, the designation of naval air units with bases abroad was changed. They were now designated by a three-digit code that indicated, among other things, their purpose and home naval district in Japan. If the first digit was 2 or 3, it was the Kōkūtai, whose specialty was exclusively fighter aircraft. The Tainan Kōkūtai became Kōkūtai 251, and similarly were designated Kōkūtai 201 (formerly Chitose Kōkūtai), Kōkūtai 202 (formerly 3rd Kū.), Kōkūtai 204 (formerly 6th Kū.), Kōkūtai 252 (formerly Genzan Kū.), and Kōkūtai 253 (formerly Kanoya Kū. Fighter Squadron). The mixed purpose 2nd Kōkūtai was designated Kōkūtai 582 and retained both the single-engine bombers and the fighter unit. The former Tainan Kōkūtai moved to Japan in mid-November to replace losses, to train reinforcements, and to take over new equipment. Guadalcanal, which the Japanese called "Ga Shima", was a high risk target during any long distance flight due to unpredictable weather, possible engine failure, fatigue, or nausea caused by tropical diseases. At the same time, the Japanese faced an enemy that was constantly improving its technology, tactics, logistics, and infrastructure.

In late 1942, the Japanese attempted to open an airfield on Munda Island, just 300 km from Guadalcanal, but Allied air raids made using this base very difficult. In late January 1943, the evacuation of Japanese troops from Guadalcanal was completed. At that time, the fighter unit of the carrier Zuikaku began operating from Bougainville and withdrew to Truk after two weeks. A month later, a fighter unit from the carrier Zuihō was deployed in a similar way. This practice proved successful for the Navy and was used in the area for the following year. The Japanese command decided in late March 1943 to achieve air supremacy in the New Guinea and Solomon Islands area. Therefore, the Operation "I-gō" was planned, in which raids were conducted between April 7 and 14 against Guadalcanal, Oro Bay, Port Moresby and Milne Bay. More than 200 A6M2 and A6M3 aircraft were available for fighter escort from Kōkūtai 204, 253, and 582 and from the fighter units of the carriers Zuikaku, Zuihō, Junyō and Hiyō. The result of the action was judged as a great success. However, both sides actually suffered negligible losses. After the operation ended, on April 18, a bomber with Admiral Isoroku Yamamoto on board was shot down over Bougainville Island during an inspection tour. Based on decoded radio intercepts, American P-38 fighters were in the right place at the right time. The commander of the Combined Fleet and one of the architects of the attack on Pearl Harbor died exactly one year after Doolittle's raid on Tokyo.

In May 1943, Kōkūtai 251 returned to Rabaul, just in time to join the attacks on Allied forces fighting their way from Guadalcanal farther northwest. The Japanese made a tremendous effort to stop the offensive, but their efforts were futile. The Japanese made their last raid on Guadalcanal on June 16, 1943. Of the 24 dive bombers, 13 crews were lost and the fighter escort of 70 Zeros had to write off 15 aircraft. The Allies suffered minimal losses.

Retreat and defense of Rabaul

In late June 1943, the Allies landed on New Georgia and captured Munda airfield. This was followed by the defensive battles of Vella Lavella in August and Buin during September and October. In this period Zero pilots met F6F Hellcat fighter in combat for the first time. Kōkūtai 201 returned to the battlefield from Japan and naval fighters in the area were reinforced by the carrier-based fighter units

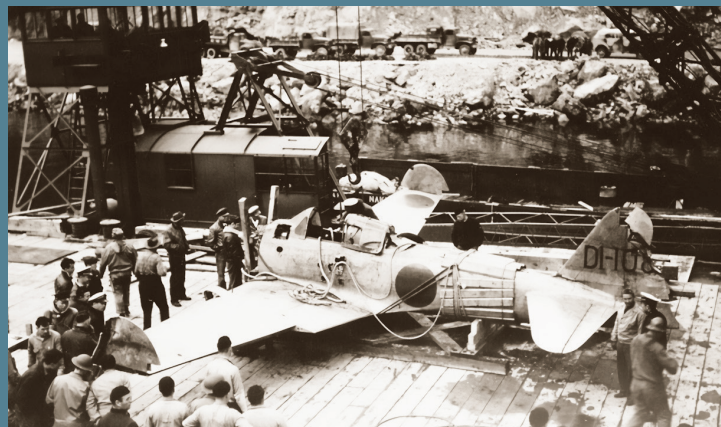

Koga's Zero pictured in Dutch Harbor, Aleutians during transport to the US. The colour of this relatively new aircraft was described by the Americans in a technical report as "glossy grey-green".



Aircraft prepare to launch from Japanese carrier Shōkaku during Battle of the Santa Cruz Islands, October 26, 1942.

of HIJMS Junyō and Ryūhō. The Zero pilots managed to keep their win-loss ratio at a reasonable level in combat with enemy fighters. However, bomber crews were constantly suffering high losses. It was a problem for which the high command had no solution. The „Kate“ and „Val“ bombers were already obsolete, and their design provided little protection against heavily armed Allied fighters. At the end of October 1943, the last fighter units withdrew from Bougainville to Rabaul. They began to face a systematic bombing campaign by aviation units of Marine Corps, Air Force and Navy as well as other Allied air forces. The core of the defense of this strategic base was Kōkūtai 201, 204 and 253. At the time, they used A6M fighters Type 22, 52 as well as good old 21. They were briefly supported or resupplied by carrier units. In November, for a short time, fighters arrived from Zuihō, Shōkaku and Zuikaku. In late December 1943 they were followed briefly by Zero pilots from Hiyō and Ryūhō. From the Japanese point of view, during this period Rabaul could be likened to a meat grinder. In early January Kōkūtai 201 had to be withdrawn. After less than a month exhausted Kōkūtai 204 moved from Rabaul too. Losses were replaced by fighters from the carriers Jun'yō, Hiyō and Ryūhō, who together with Kōkūtai 253 held out for a month in defensive aerial battles. In late February 1944, fighter units began to withdraw from Rabaul to Truk. Although the high command promised to turn the units back, this never happened, and the Allies neutralized the base until the end of the war. With the end of the fighting over Rabaul, the Japanese naval air force lost most of its seasoned fighter veterans.

China, India, and Indonesia

As Allied air raids against targets on the Chinese mainland and Taiwan intensified, the Japanese Navy decided to establish Kōkūtai 254. In October 1943, it began operations in Hong Kong, and detachments later operated from other bases. In February 1944, Kōkūtai 256 was formed in Central China. Their opponents were primarily American bombers. By the end of 1944, both units were deployed in the defense of Taiwan and the Philippines. Due to heavy casualties, their remaining parts were absorbed into another unit in January 1945.

The Japanese Army Air Force had to focus on fighting for northern New Guinea in 1943. Therefore, the Japanese Naval Air Force took over their area of operations in the Indian Ocean. In July, Kōkūtai 331 was established with this task. The main base was Sabang, north of Sumatra and the unit also used airfields in the Andaman and Nicobar Islands, where it primarily faced the RAF. However, it also operated in Thailand and Burma. For a short time, it was a mixed unit that also used single-engine bombers.

In October 1943, Kōkūtai 381 was formed. Its main task throughout the following year was the defense of the oil refineries in Borneo. With A6M2 Type 21 fighters, Kōkūtai 381 conducted about half of its fighter sorties at night. Phosphorus air-to-air bombs were often used during the interception missions. The Kōkūtai 381 was gradually expanded to include other parts that used twin-engine night fighters and single- and twin-engine bombers. Nevertheless, it retained its designation as an interceptor unit.

Marshall, Caroline, and Mariana Islands

In early 1943, Kōkūtai 201, which had withdrawn from Rabaul, was stationed with its Zeros in the Marshall Islands. After transfer to Japan, this area was taken over in February 1943 by Kōkūtai 252. It had bases primarily on the islands of Kwajalein, Maloelap, Nauru, Roi, and Wake. The Unit mostly encountered American four-engine bombers, but in the fall of 1943, it went through heavy combats with US Navy "Hellcats". Therefore Kōkūtai 281 arrived in November as a reinforcement. During the capture of the Marshall Islands in February 1944, Kōkūtai 281 was completely destroyed, and its last pilots were killed in ground

combat. Part of Kōkūtai 252 was evacuated to Japan. At the beginning of 1944 Zero Type 21 began to be used also as fighter-bomber. One of the first units to take over the Zero for this purpose was the bomber Kōkūtai 501. From January 1944, fighter-bomber pilots were trained at Truk. Kōkūtai 201 and 204 also withdrew to this area from Rabaul. However, after fighting with US Navy aircraft, the remnants of these units flew to the Philippines in March or were absorbed by other units. They were replaced by several newly organized Kōkūtais. Some were already to be armed with the new "George" and "Jack" fighters, but all ended up using A6M Zeros, primarily Type 52, partly also Type 21. Prior to the Battle of the Marianas, Kōkūtai 261 was stationed in the area of Saipan and Meleyon, Kōkūtai 263 on Guam, Kōkūtai 343 on Tinian, Kōkūtai 202 on Moen and Truk, and Kōkūtai 253 on Eten.

A major reorganization took place in the carrier units. Within new organization they were divided into three Kōkūtai units. The bombers, fighters, fighter-bombers, and reconnaissance aircraft on the HIJMS Taihō, Shōkaku, and Zuikaku fell under Kōkūtai 601. Kōkūtai 652 operated from the decks of HIJMS Jun'yō, Hiyō, and Ryūjō, and Kōkūtai 653 airmen were assigned to the carriers Chiyoda, Chitose, and Zuihō. Among the new specialties of the carrier units were the fighter-bombers. Their mission was to attack vessels that were protecting enemy carriers. The purpose was to damage or sink them and draw part of the AA fire from bombers. For this purpose, seven of the above vessels had on board squadrons of A6M2 Model 21 fighter-bombers (see, e.g., Marking J).

The Battle of the Philippine Sea, which occurred on June 19 and 20, 1944, was the largest carrier engagement in history. A Japanese task force of nine carriers faced fifteen American "flat tops". It was also the last combat action in which Zero Type 21 was deployed as a carrier embarked airplane. In a devastating defeat Japanese lost more than 600 aircraft and three carriers. The inadequate experience of the newly trained airmen was on full display. Also contributing to the defeat was the fact that many of the ships' commanding officers were ten years younger in seniority than their predecessors in 1942 battles. A large number of them also had no extensive flying experience.

The Philippines and the defense of Japan

Since early Fall 1944, the Japanese Army and Naval Air Forces faced air raids on the Philippines, culminating in the landing in Leyte on October 20, 1944. At that time, the Japanese command came to a difficult decision that had long been discussed and was intended to help increase the effectiveness of the fight against enemy vessels. The first Kamikaze units were formed, whose airmen were to sacrifice themselves by crashing into enemy ships. All types of aircraft were used for this purpose until the end of the war, including the A6M-2K two seat trainers and A6M2 Model 21 fighters (see Marking K). Kamikaze units were formed from both combat and training Kōkūtai units. Nearly 4,000 Japanese Army and Navy aviators sacrificed their lives in this manner. The Allies were initially surprised by this tactics. Kamikaze pilots caused approximately 80 % of Allied ship losses in the last ten months of the war. They destroyed aircraft carriers USS St. Lo, Ommaney Bay and Bismarck Sea, along with 14 destroyers and about 30 other vessels. Several hundred ships were damaged, some beyond repair. Kamikaze attacks cost the lives of 5,000 Allied crew members and about the same number were injured. Even this ultimate measure, however, did not prevent Japan's defeat.

When Allied troops occupied air bases in Japan after the surrender, they still found among the aircraft from combat units some A6M2 Model 21 fighters. One of these is documented at Kōkūtai 302 with the air victory symbol on the tail. After four years of war in the Pacific, the "twenty-one" faced far more modern enemy aircraft while it kept same design as it had during Pearl Harbor attack.

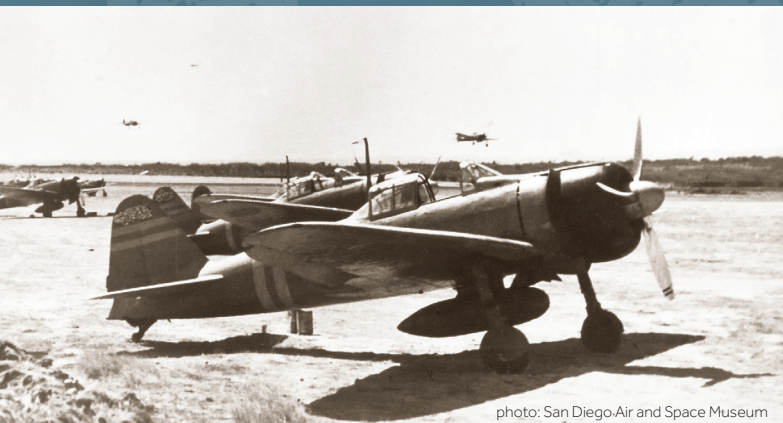

photo: San Diego Air and Space Museum

Fighters from the 3rd Kōkūtai at Kupang airfield, Indonesia in 1942. Note the difference between the light identification stripes and bands as compared to grey color of the aircraft, which appears relatively dark.



photo: San Diego Air and Space Museum

Part of Tainan Kōkūtai pilots in Lae, New Guinea in June 1942. Saburō Sakai is in the middle row second from the left, Hiroyoshi Nishizawa is standing to the far left.

ATTENTION



UPOZORNĚNÍ



ACHTUNG



ATTENTION



注意



Carefully read instruction sheet before assembling. When you use glue or paint, do not use near open flame and use in well ventilated room. Keep out of reach of small children. Children must not be allowed to suck any part, or pull vinyl bag over the head.



Před započítím stavby si pečlivě prostudujte stavební návod. Při používání barev a lepidel pracujte v dobře větrané místnosti. Lepidla ani barvy nepoužívejte v blízkosti otevřeného ohně. Model není určen malým dětem, mohlo by dojít k požití drobných dílů.

INSTRUCTION SIGNS

* INSTR. SYMBOLS

* INSTRUKTION SINNBILDEN

* SYMBOLES

* 記号の説明

OPTIONAL
VOLBABEND
OHNOUTSAND
BROUSITOPEN HOLE
VYVRTAT OTVORSYMETRICAL ASSEMBLY
SYMETRICKÁ MONTÁŽREMOVE
ODŘÍZNOUTREVERSE SIDE
OTOČITAPPLY EDUARD MASK
AND PAINT
POUŽIT EDUARD MASK
NABARVIT

PARTS



DÍLY



TEILE



PIÈCES



部品

PLASTIC PARTS

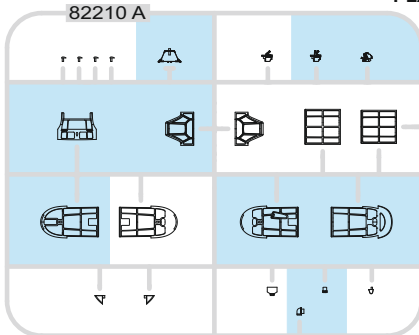
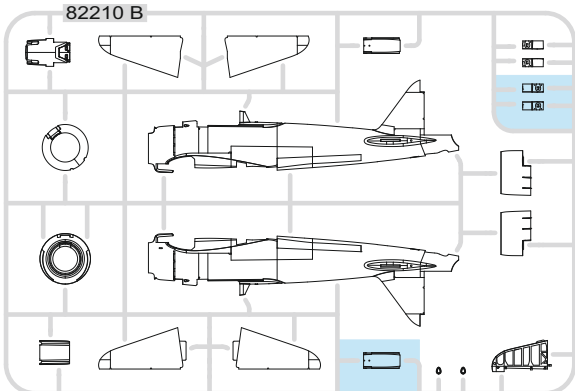
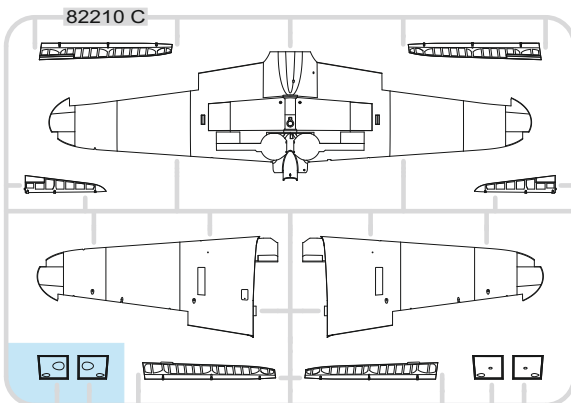
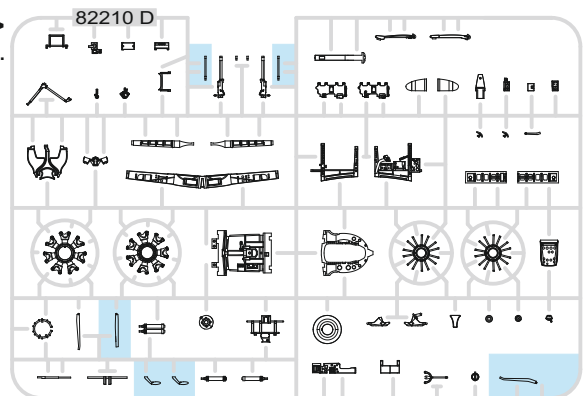
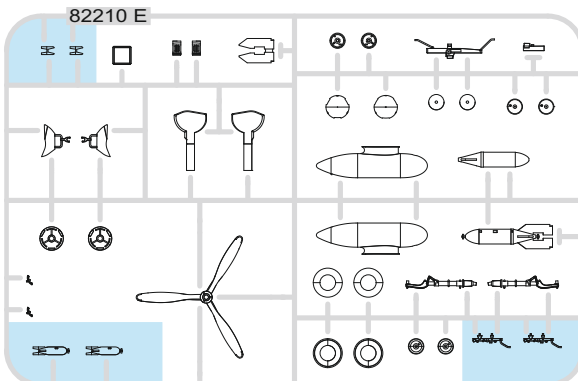
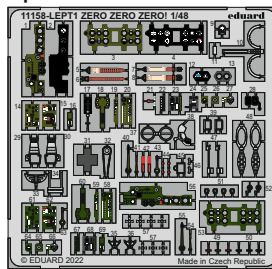
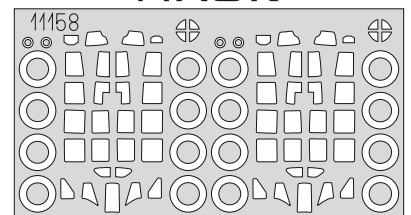
A>
2 pcs.B>
2 pcs.C>
2 pcs.D>
2 pcs.E>
2 pcs.PE - PHOTO ETCHED DETAIL PARTS
2 pcs.eduard
MASK

-Parts not for use. -Teile werden nicht verwendet. -Pièces à ne pas utiliser. -Tyto díly nepoužívejte při stavbě. - 使用しない部品

COLOURS



BARVY



FARBEN



PEINTURE



色

GSI Creos (GUNZE)		MISSION MODELS	
AQUEOUS	Mr.COLOR	PAINTS	
H2	C2	MMP-047	BLACK
H6	C6	MMP-004	GREEN
H8	C8		SILVER
H11	C62	MMP-001	FLAT WHITE
H12	C33	MMP-047	FLAT BLACK
H14	C59	MMP-005	ORANGE
H24	C58		ORANGE YELLOW
H25	C34		SKY BLUE
H47	C41	MMP-012	RED BROWN
H58	C351	MMP-059	INTERIOR GREEN
H59	C15		IJN GREEN
H63	C57	MMP-113	METALLIC BLUE GREEN
H70	C60	MMP-056	GRAY
H77	C137	MMP-040	TIRE BLACK

GSI Creos (GUNZE)		MISSION MODELS	
AQUEOUS	Mr.COLOR	PAINTS	
H90	C47		CLEAR RED
H93	C50		CLEAR BLUE
H324	C324	MMP-116	LIGHT GRAY
H336	C336		HEMP
H340	C340		FIELD GREEN
H417	C117	MMP-051	LIGHT BLUE
	C125	MMP-108	COWLING COLOR
	C131	MMP-115	RED BROWN
Mr.METAL COLOR		METALLICS	
	MC214	MMM-001	DARK IRON
	MC218	MMM-003	ALUMINIUM
	MC219	MMM-009	BRASS
Mr.COLOR SUPER METALLIC		METALLICS	
	SM201	MMC-001	SUPER FINE SILVER

1 = H58 MMP
C351 059
INT. GREEN - MARKINGS **A-F**
H340
C340
FIELD GREEN - MARKINGS **G-L**

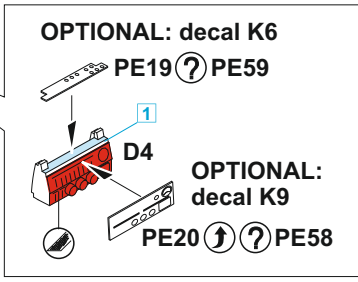
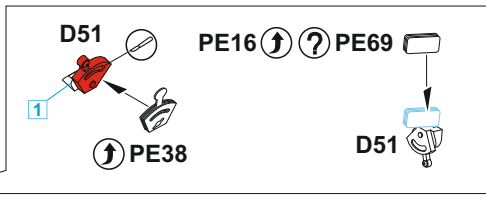
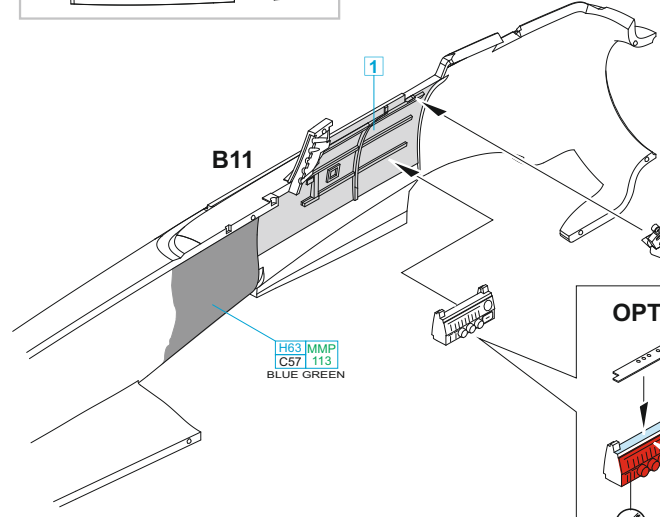
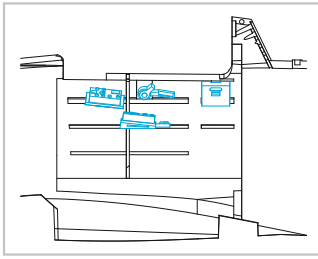
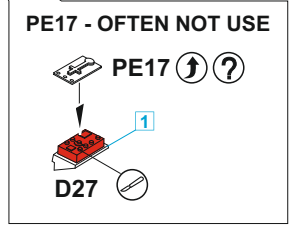
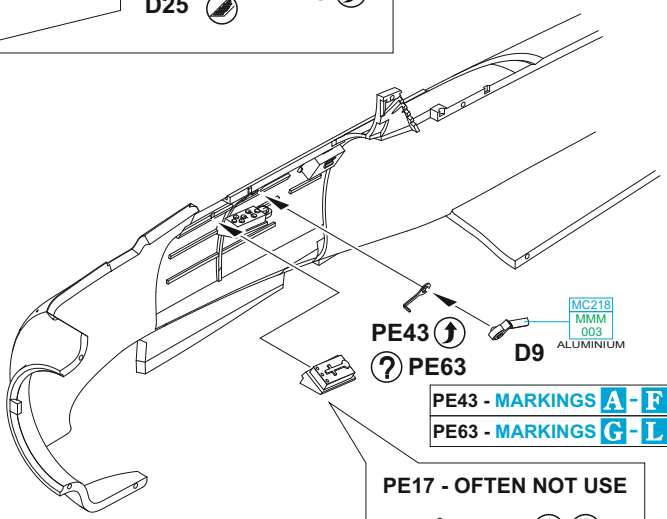
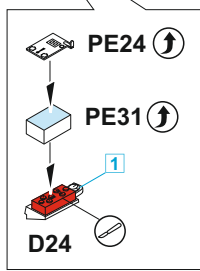
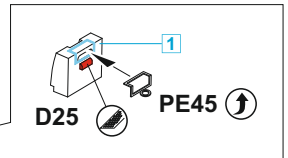
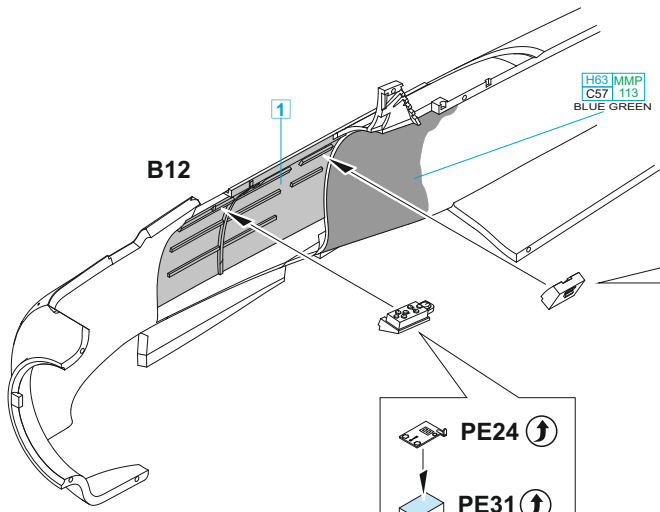

PE16, 19, 20 - MARKINGS **A-F**
PE58, 59, 69 - MARKINGS **G-L**

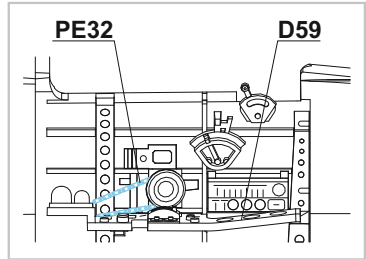
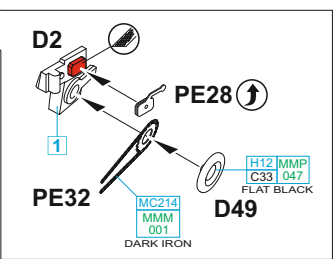
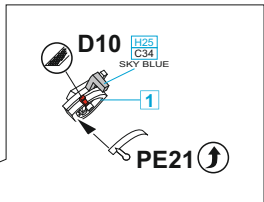
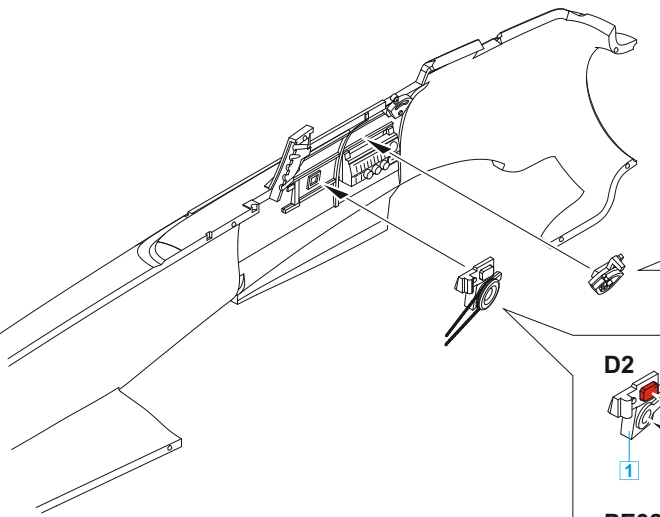
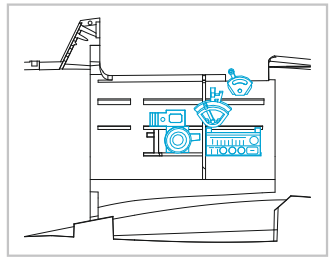

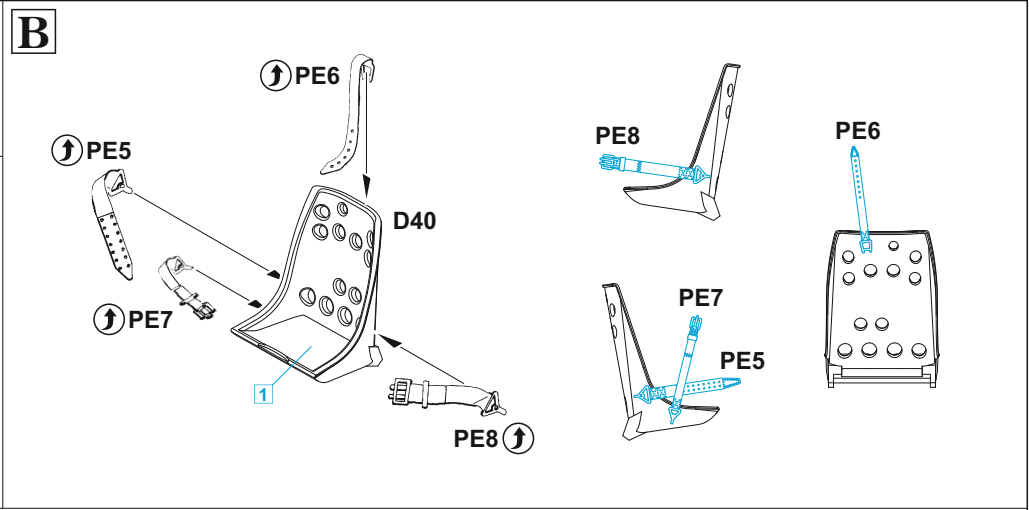
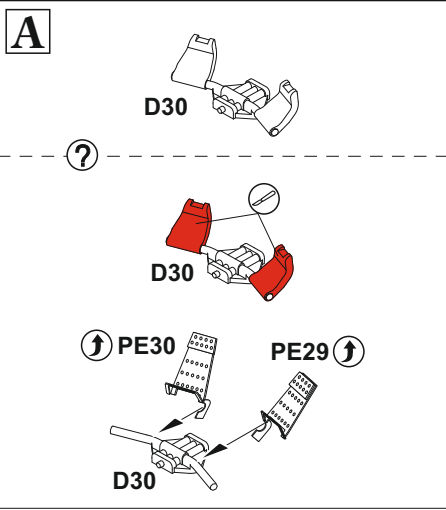

2 =

H68 MMP	C351 059	- MARKINGS A - F
INT. GREEN		
H12 MMP	C33 047	- MARKINGS G - L
FLAT BLACK		

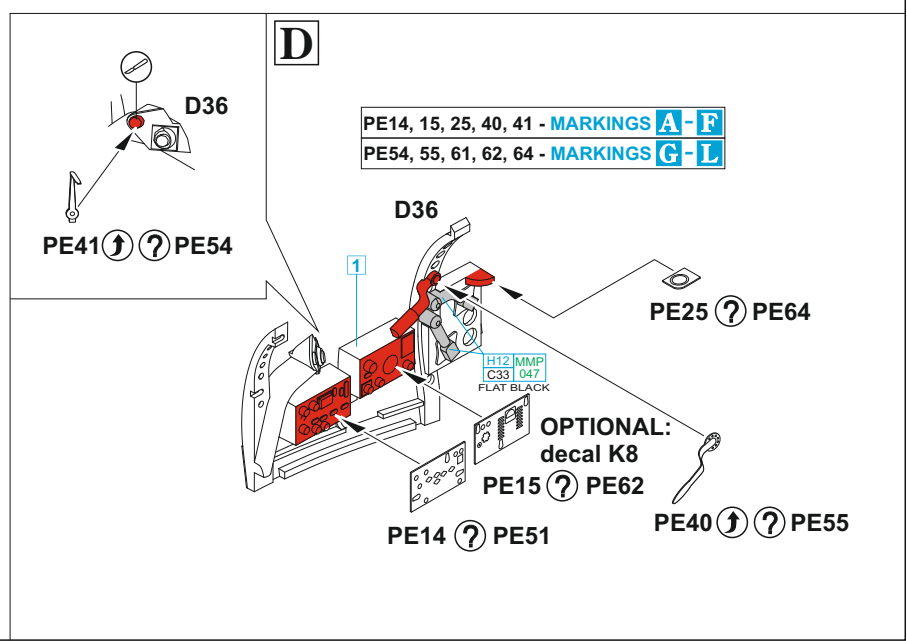
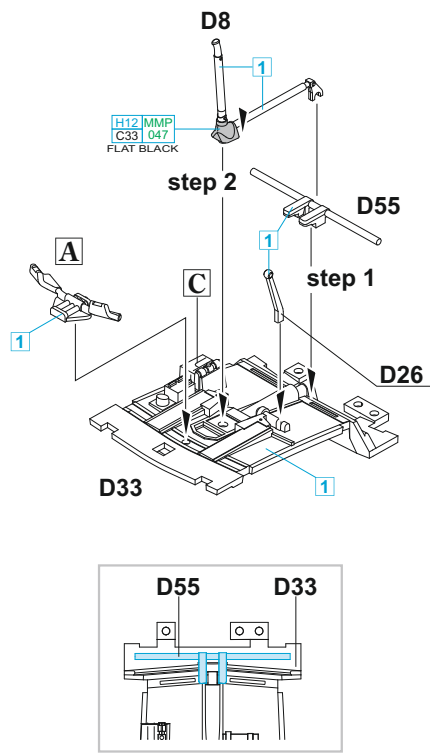
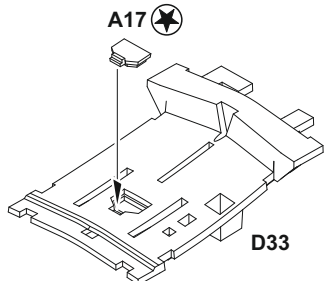
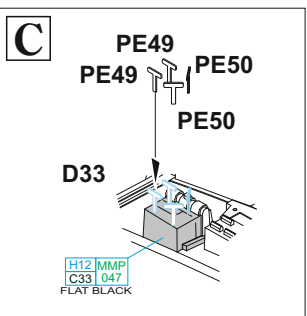
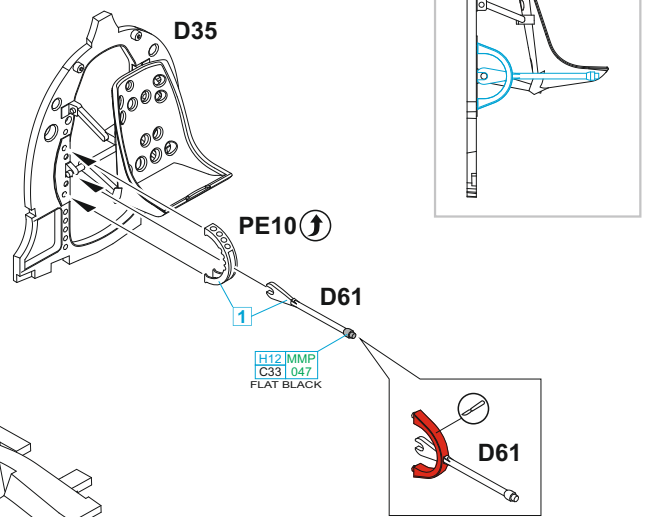
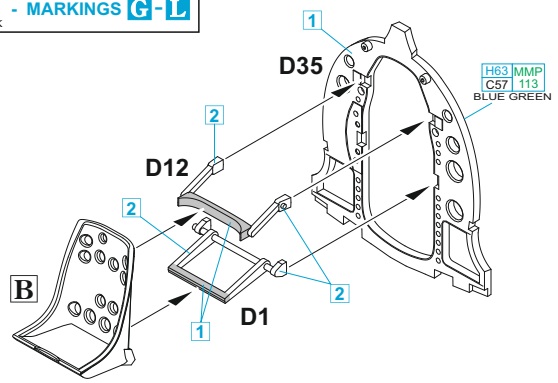

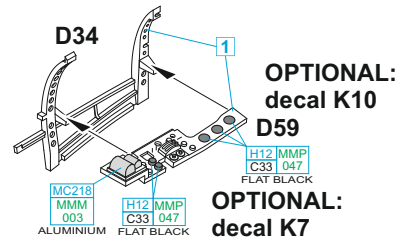
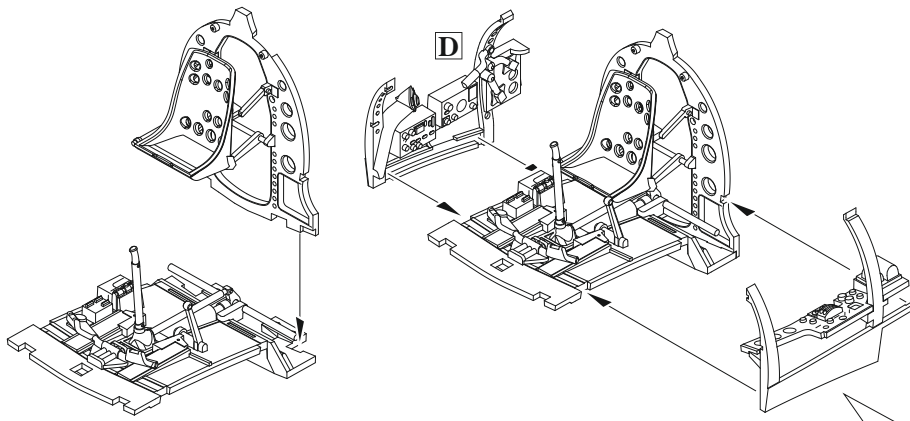

PE1, 18 - MARKINGS **A-F**
PE56, 60 - MARKINGS **G-L**

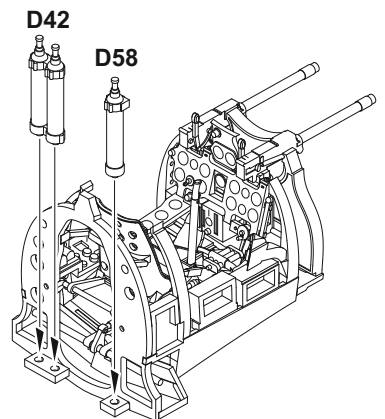
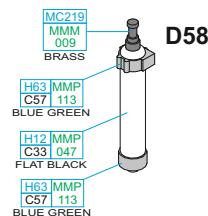
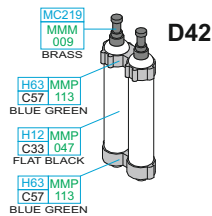
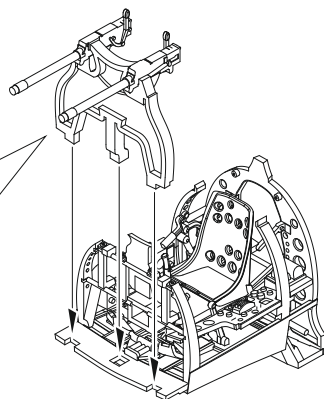
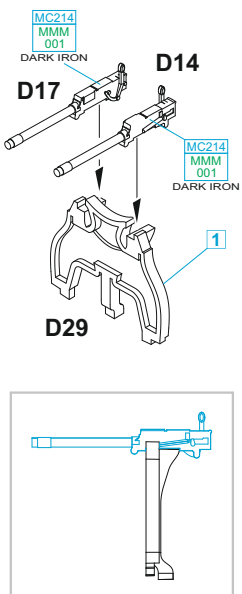
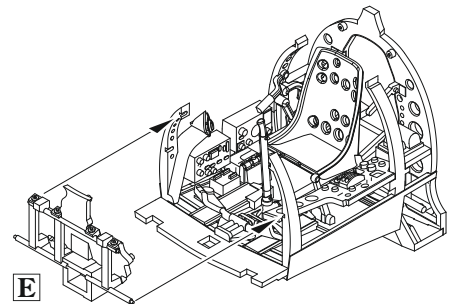
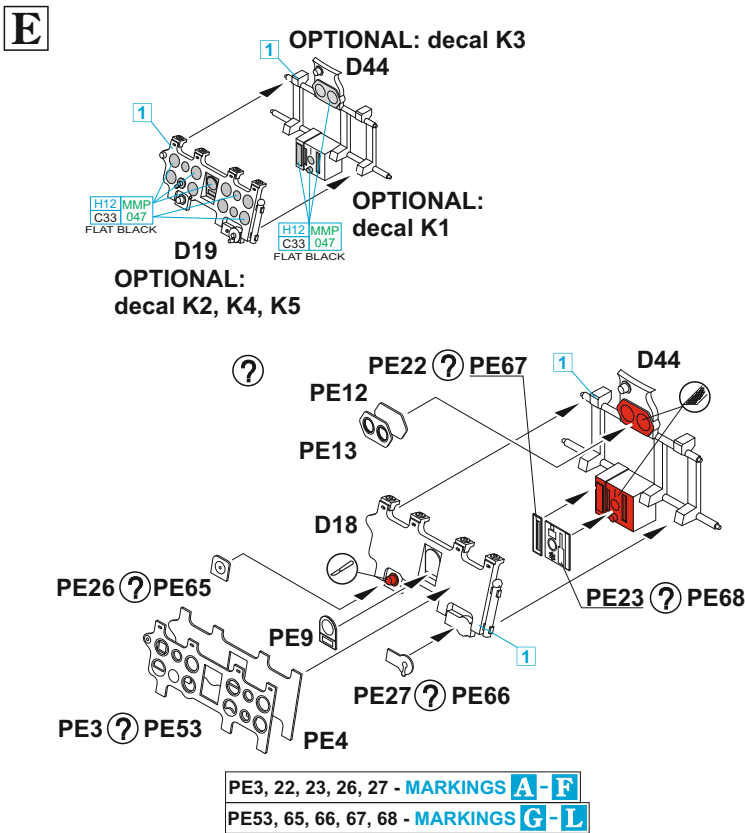
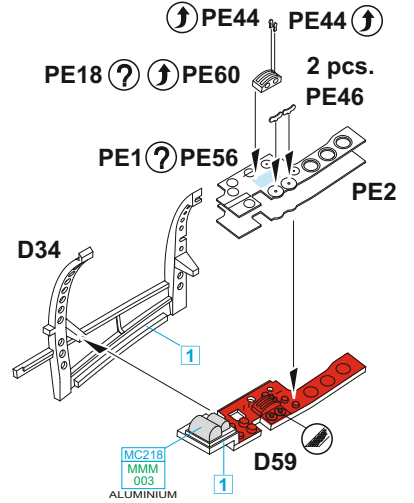

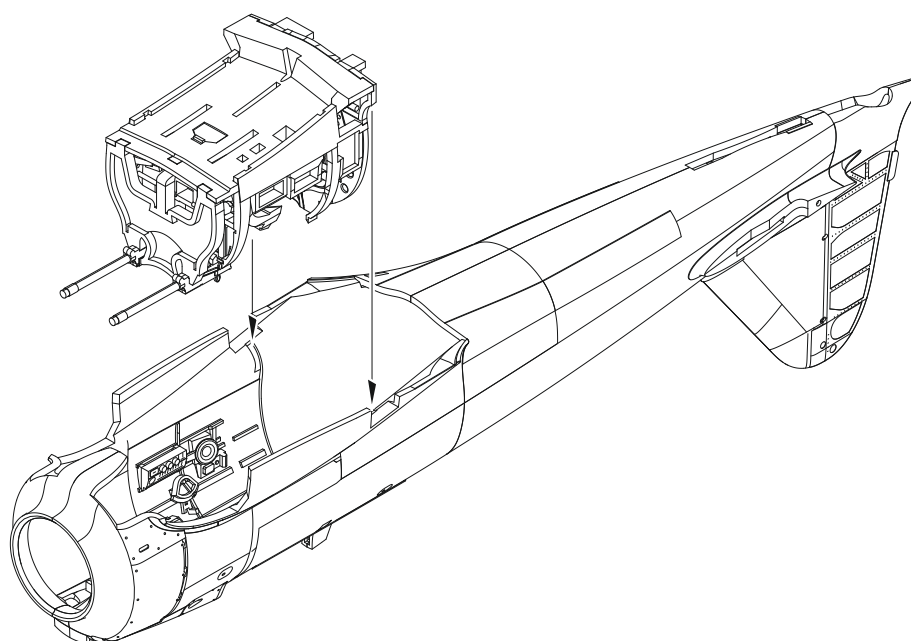
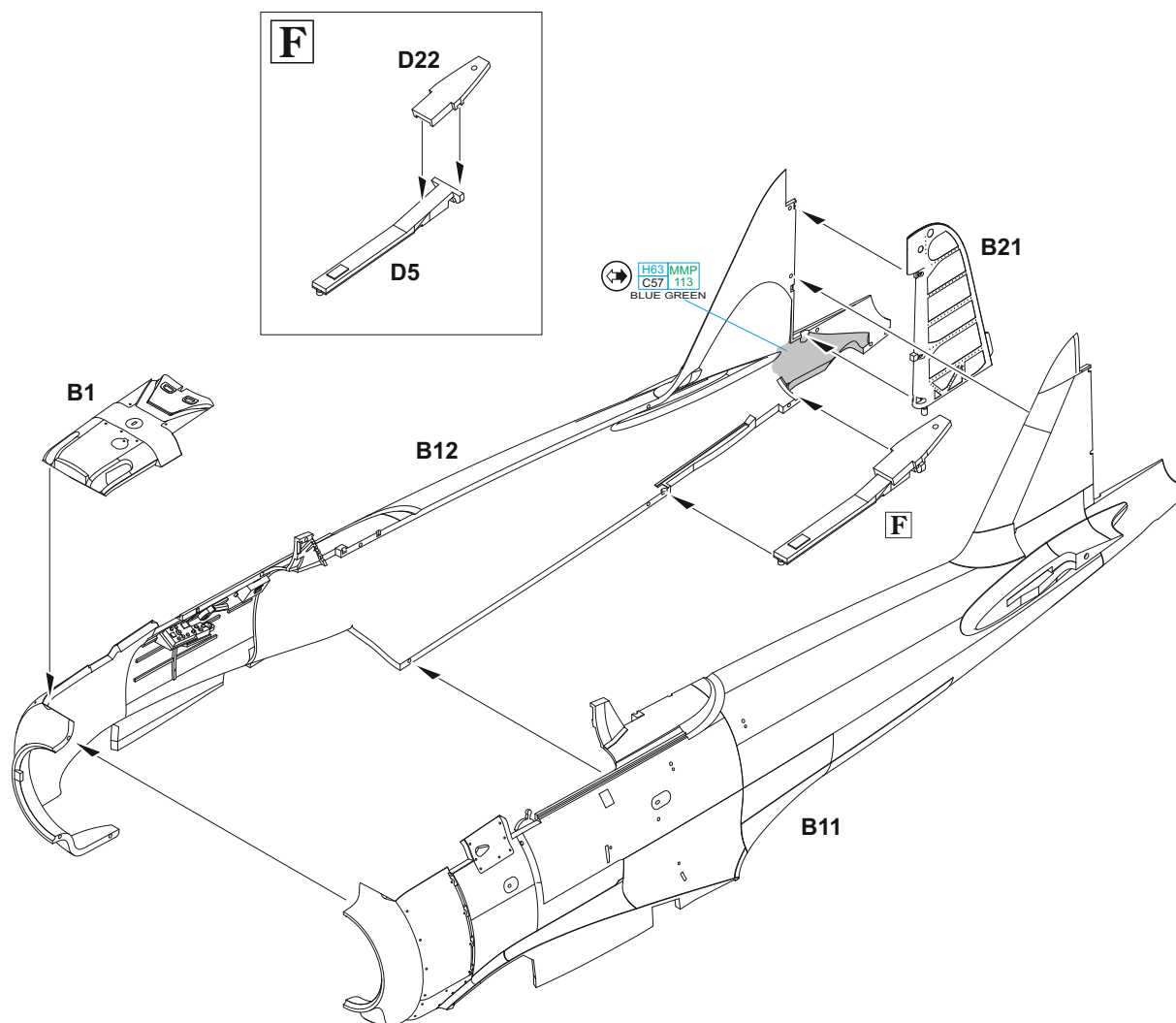

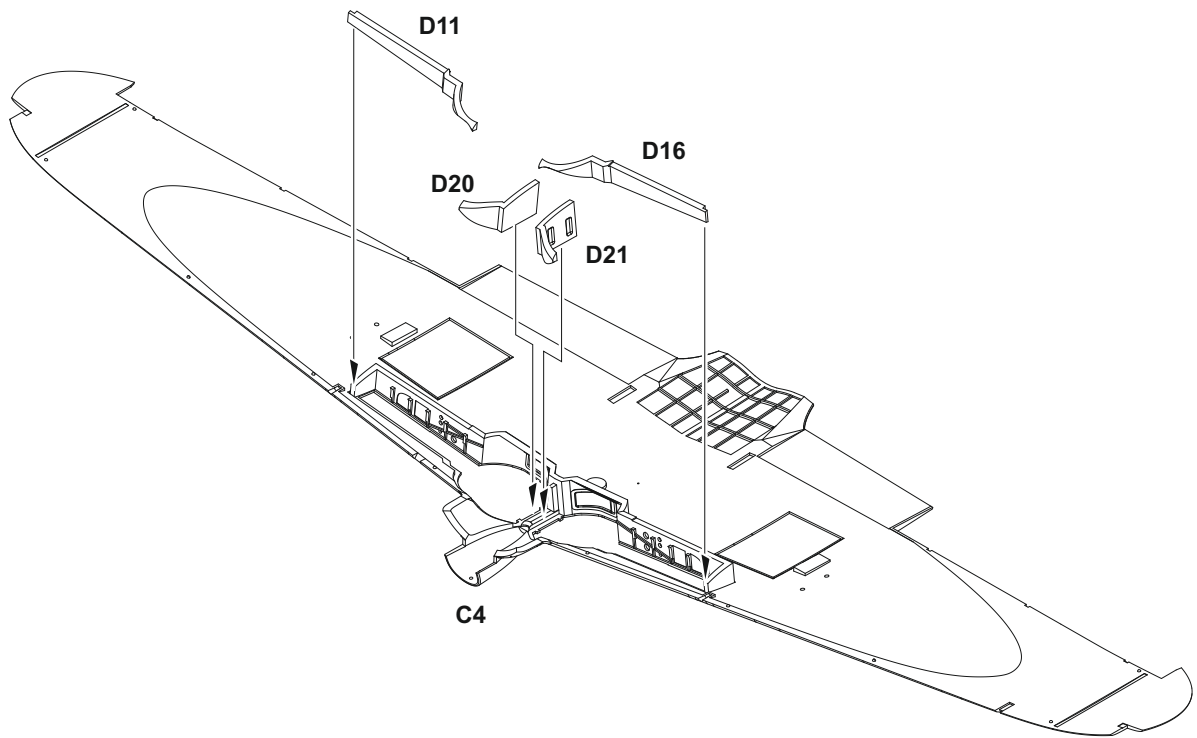
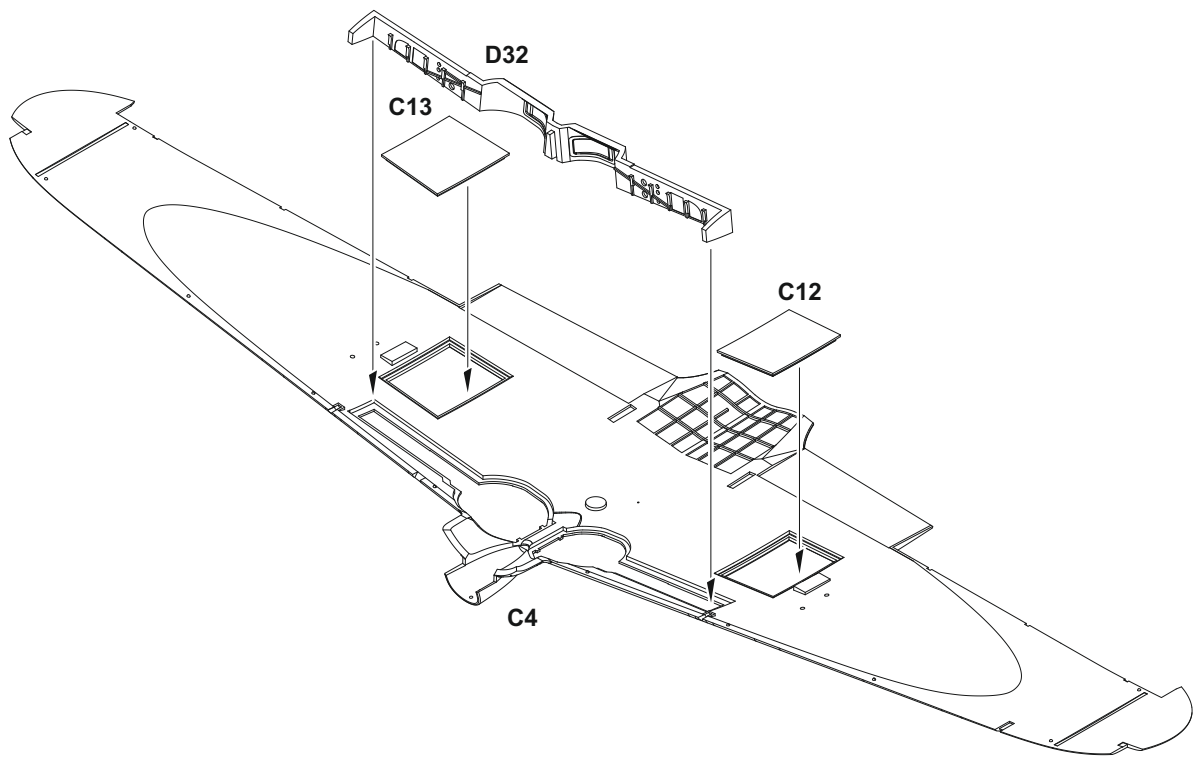

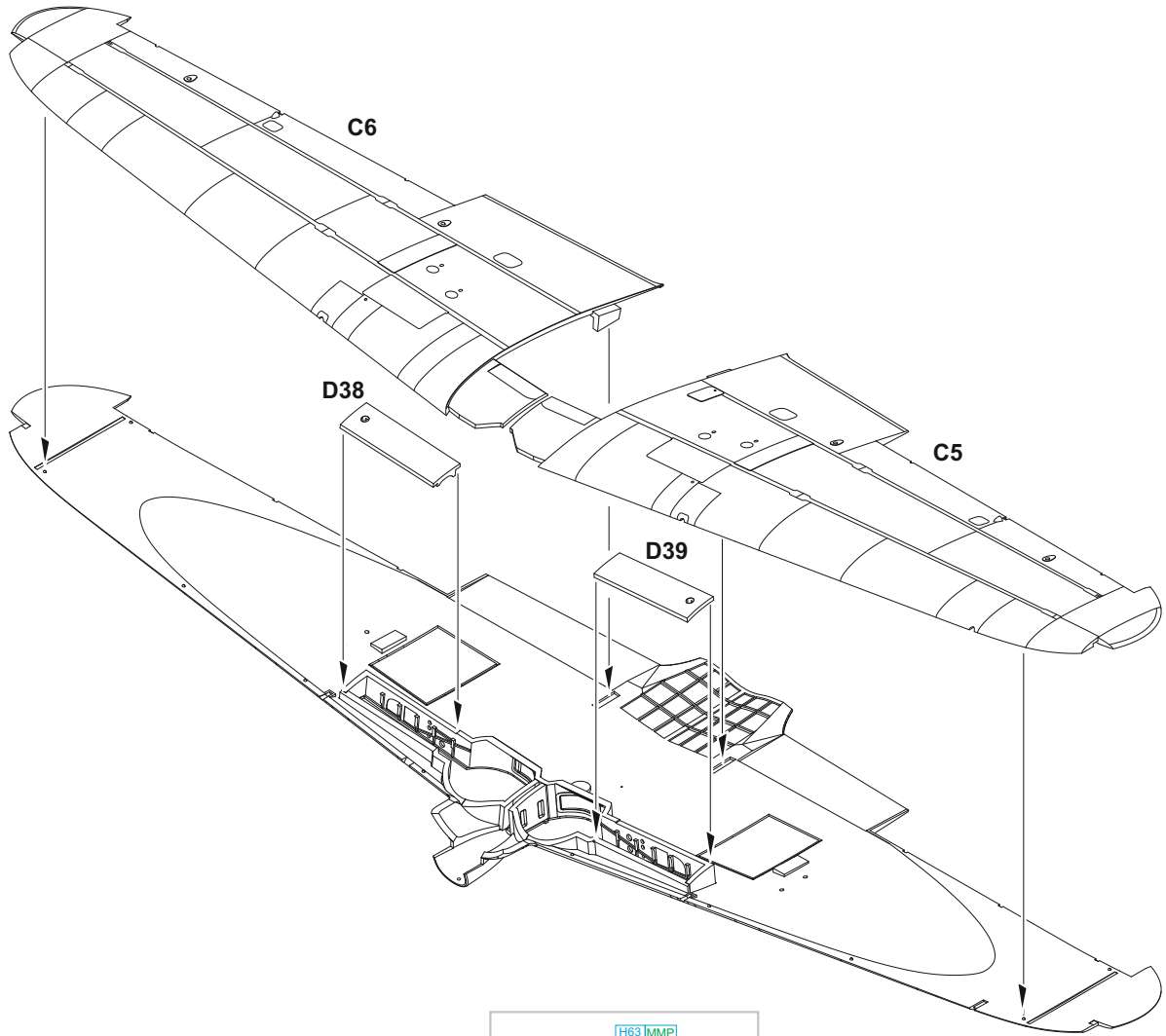

C1 - MARKINGS **D, E, F, G, I, J, K**
 C11 - MARKINGS **A, B, C, H, L**

C1 ? C11

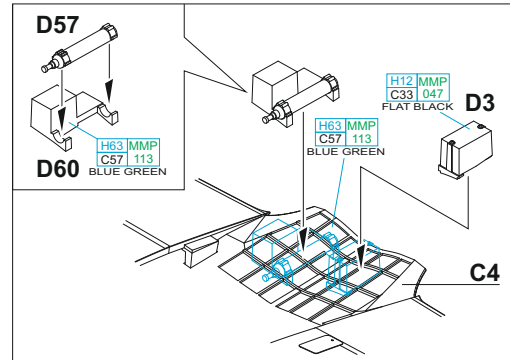
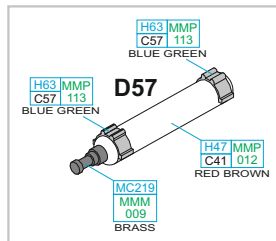

A15
 H93 C50 CLEAR BLUE

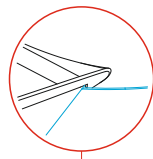
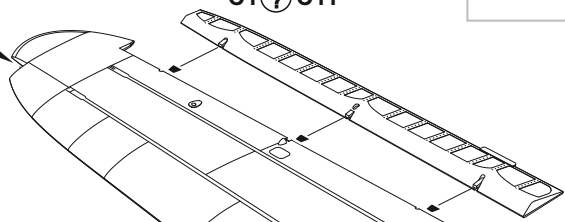

C2 - MARKINGS **D, E, F, G, I, J, K**
 C10 - MARKINGS **A, B, C, H, L**

C2 ? C10

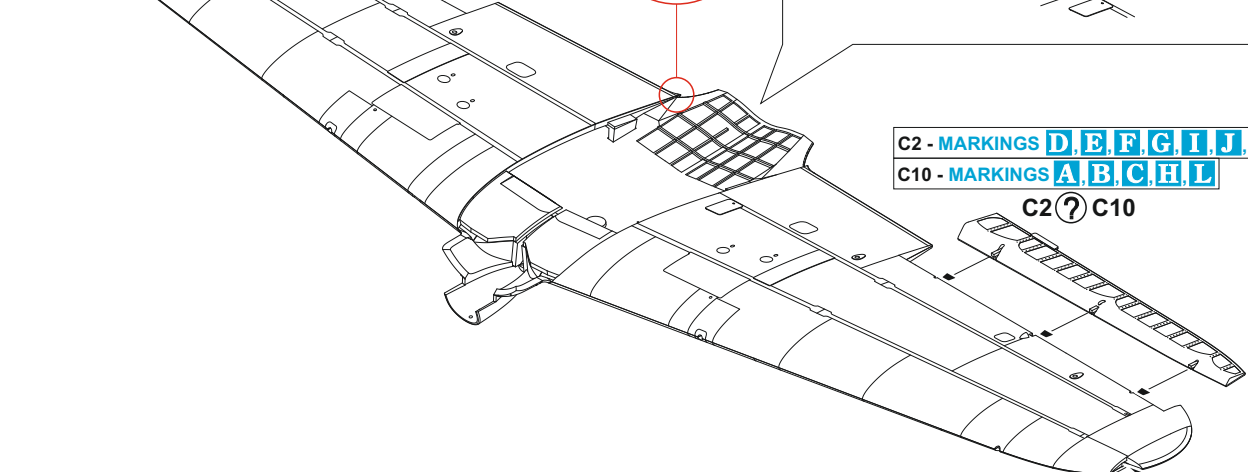

A16
 H90 C47 CLEAR RED

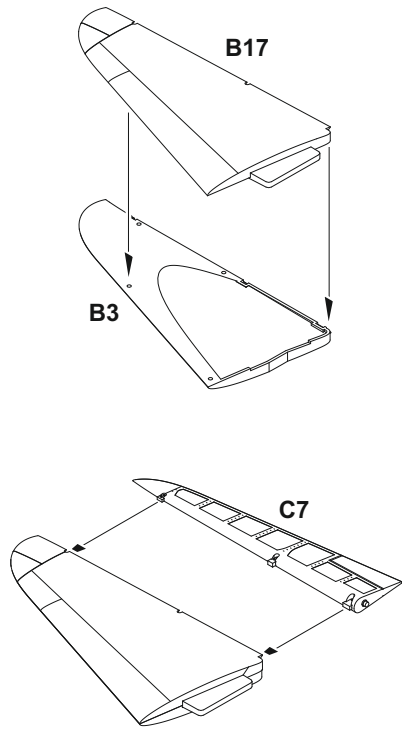
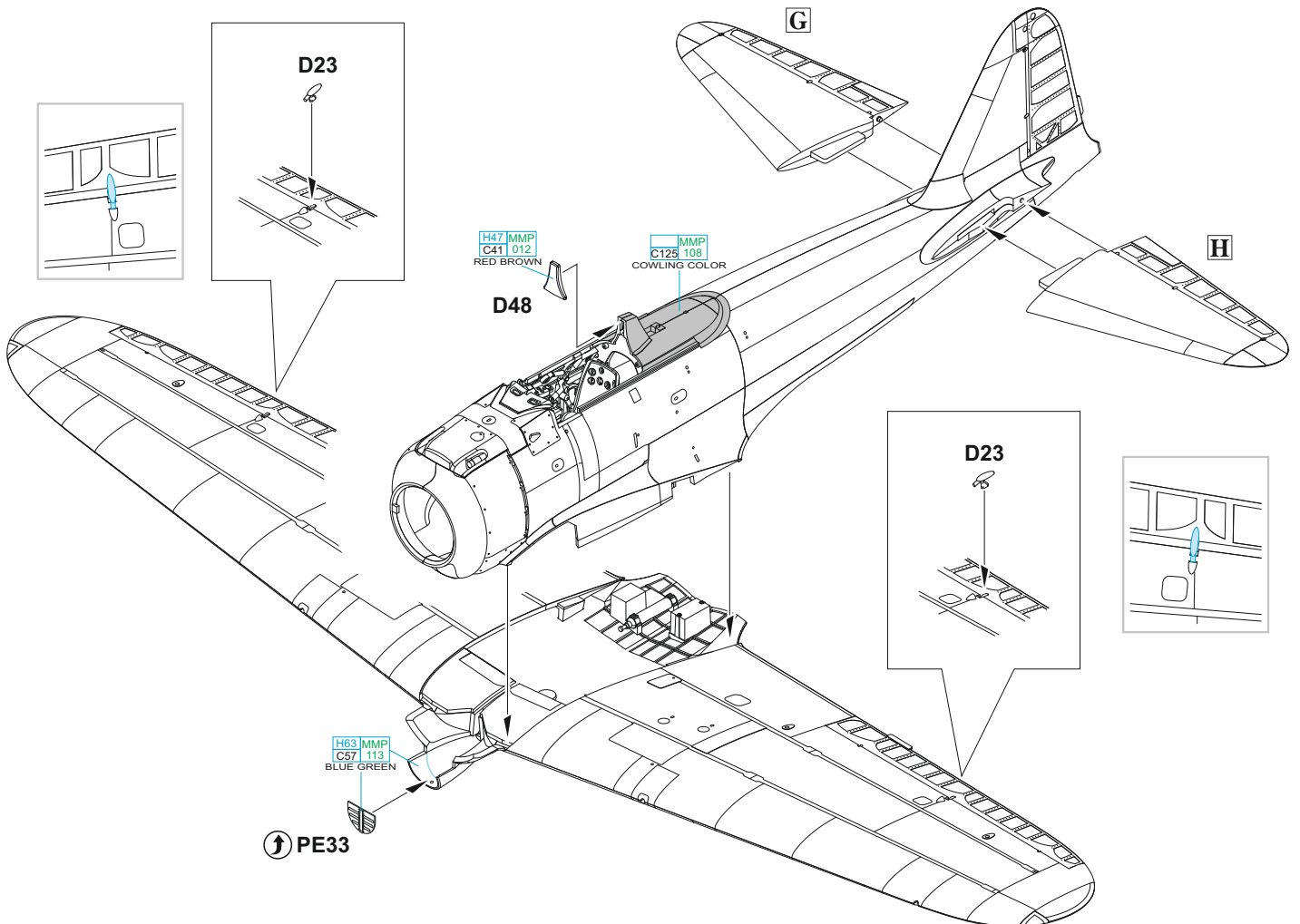
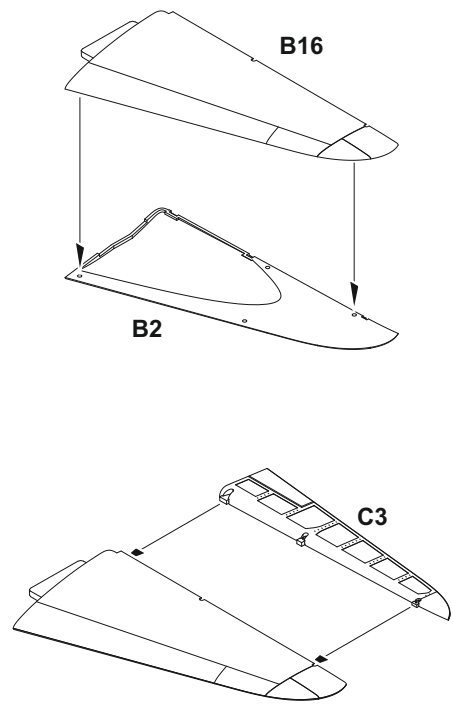
G**H**

I

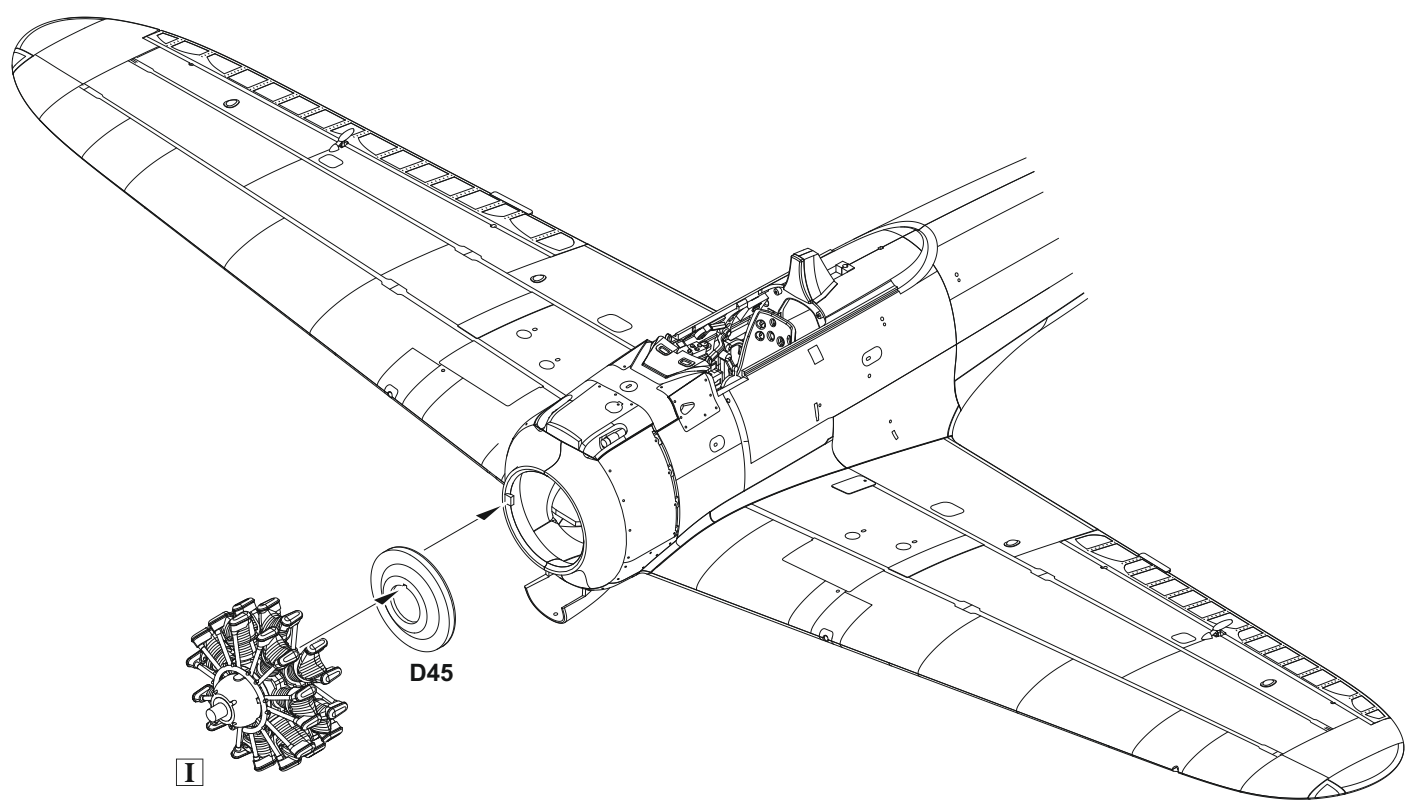
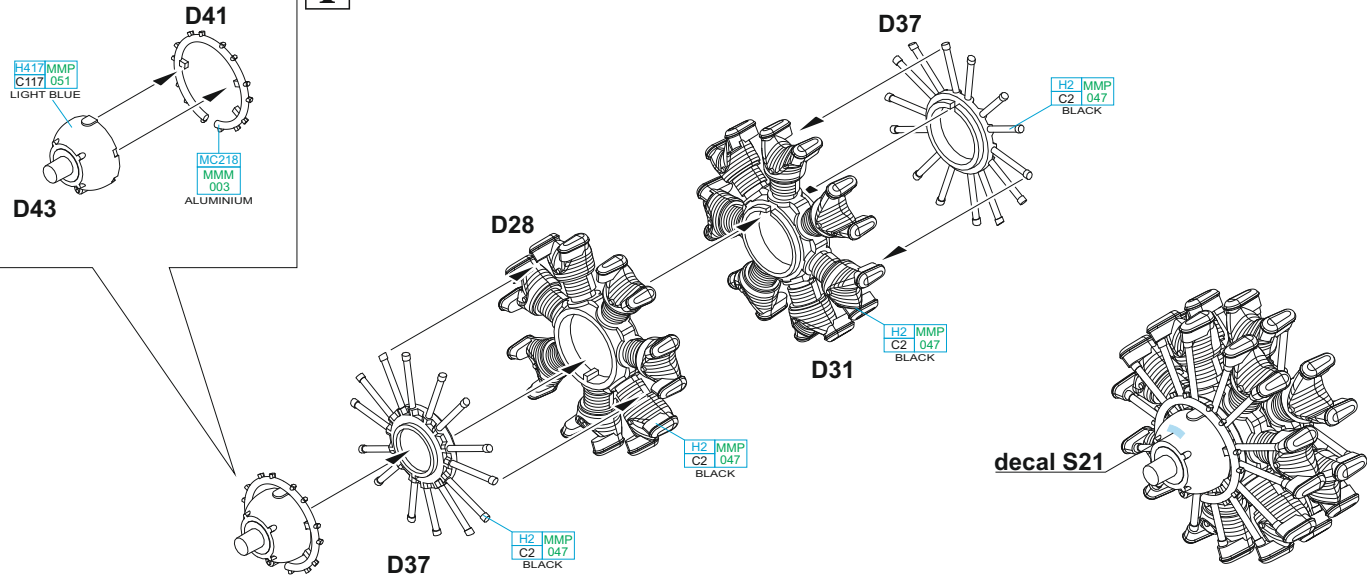

J ? MARKINGS J, K ONLY

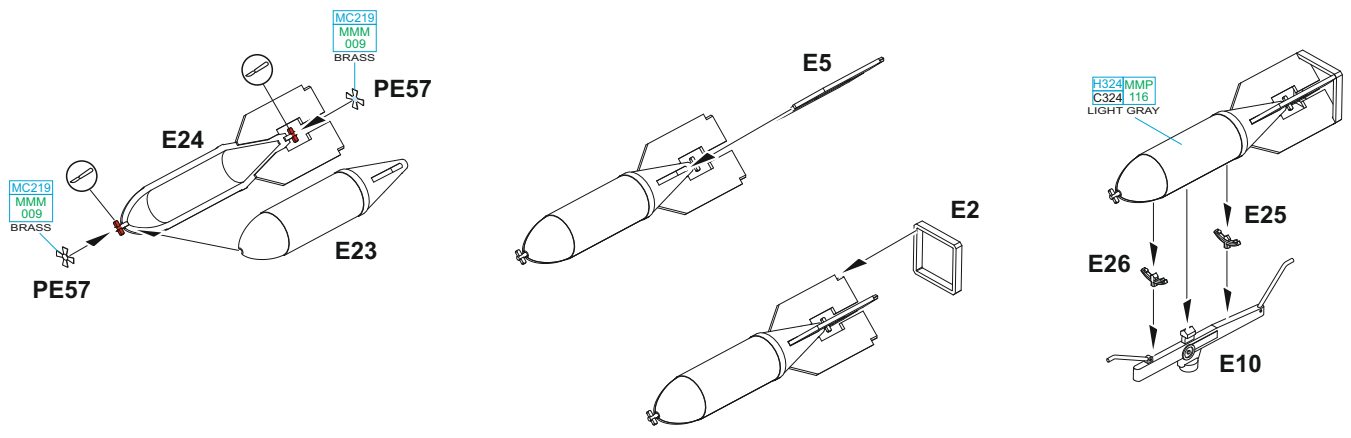

K

DO NOT GLUE!

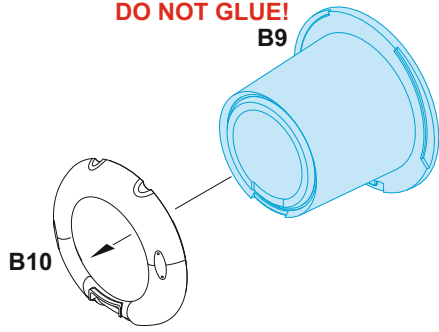

B13

DO NOT GLUE!

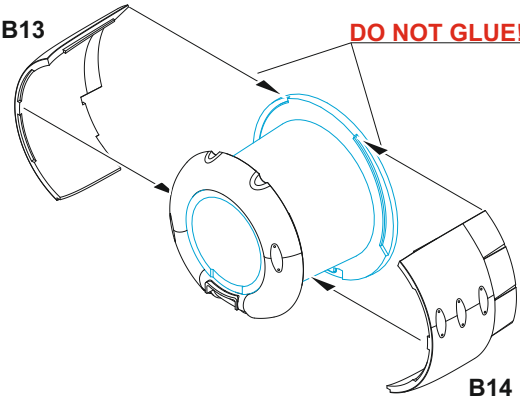

B4

DO NOT GLUE!

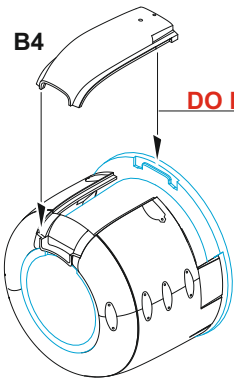

step 2
B15

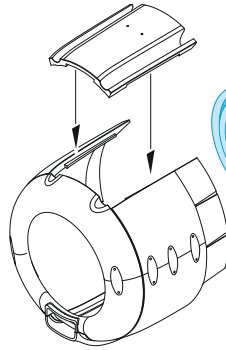

step 1
B9

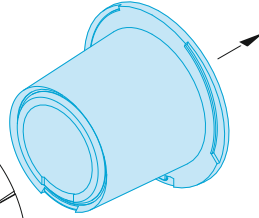

B19
MC214
MMM
001
DARK IRON

B6



B20
MC214
MMM
001
DARK IRON

B5

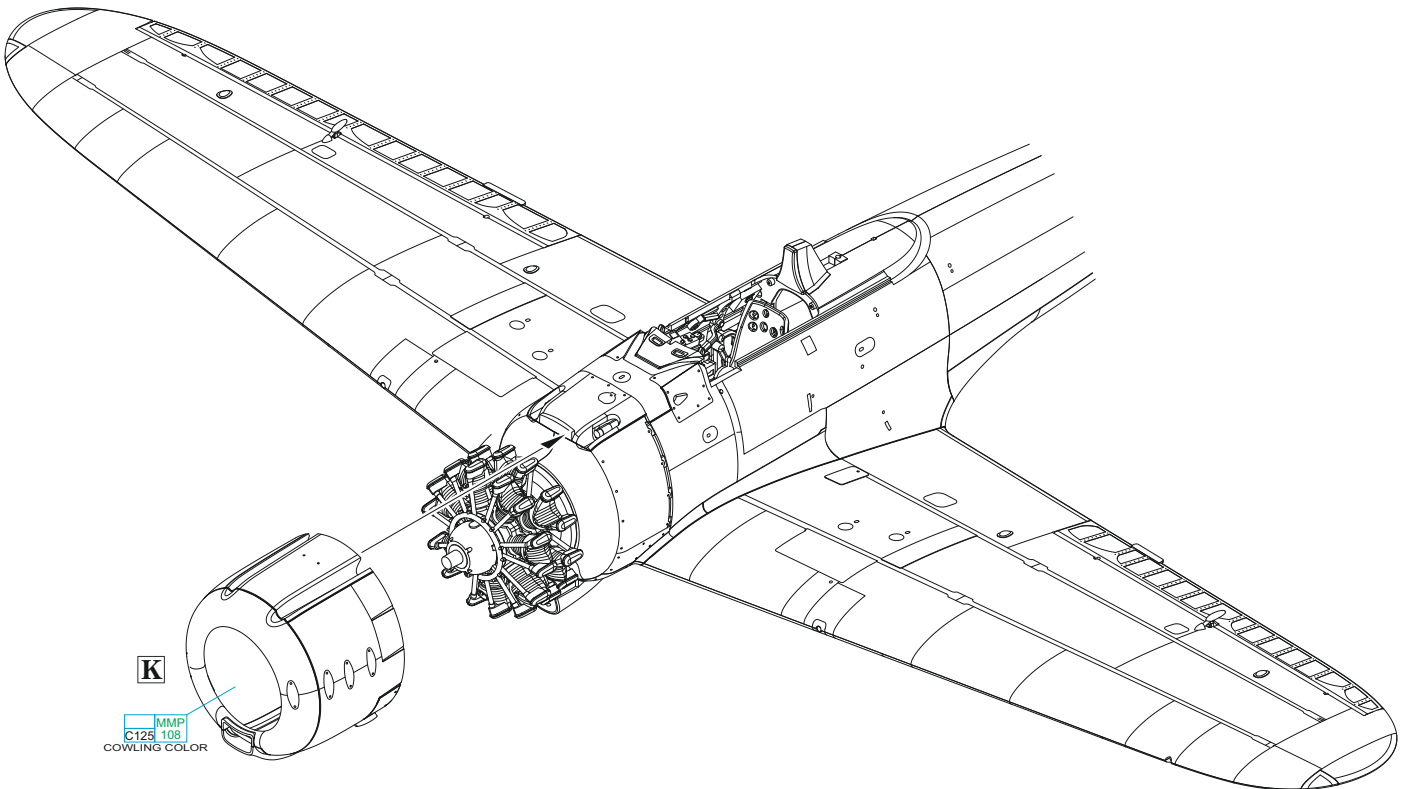
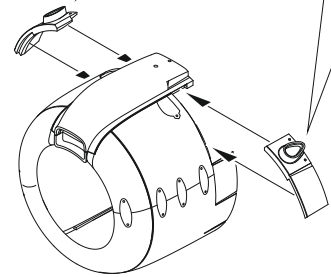
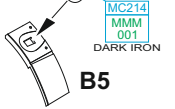

K

MMP
C125 108
COWLING COLOR

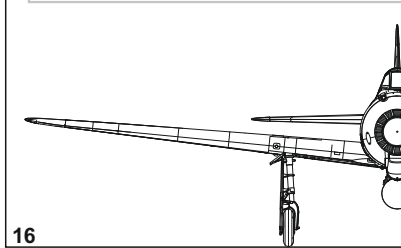
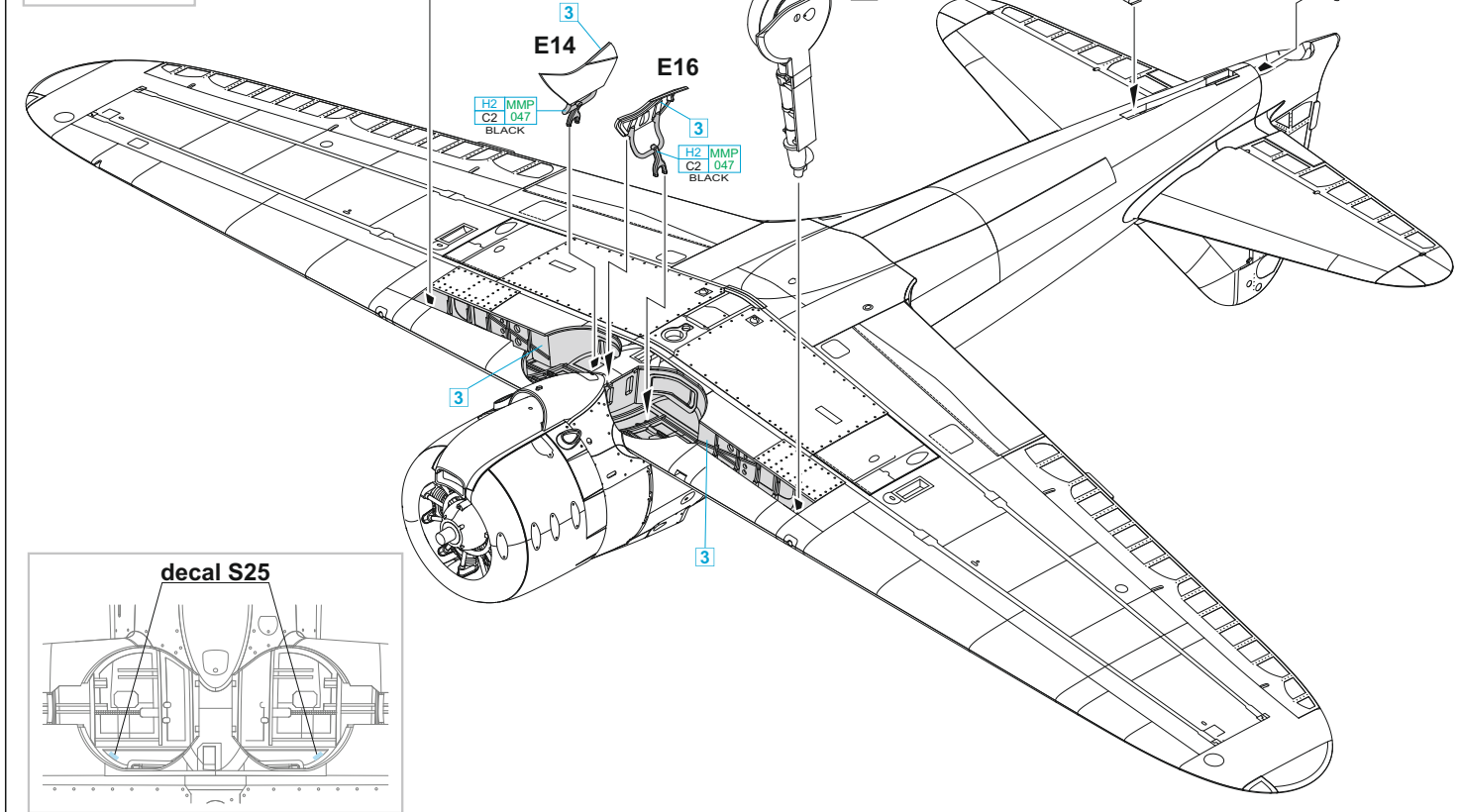
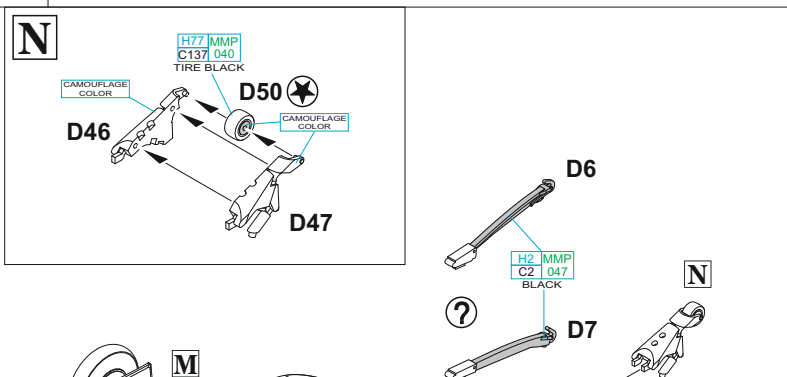
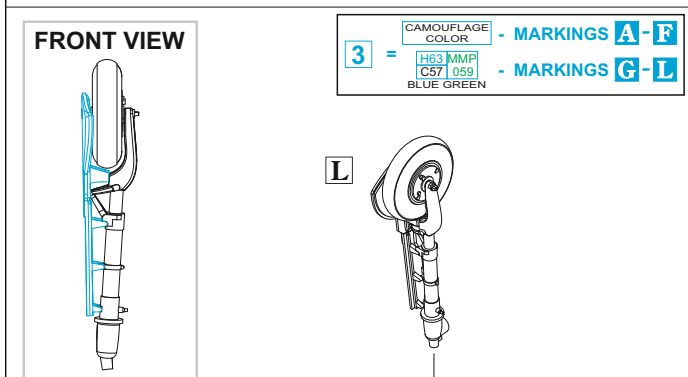
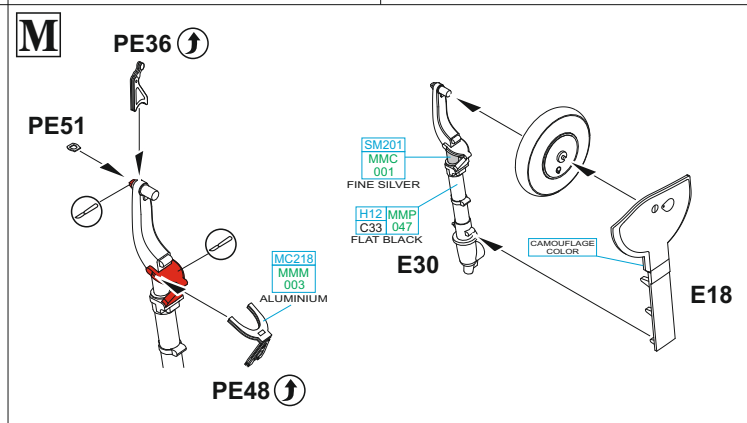
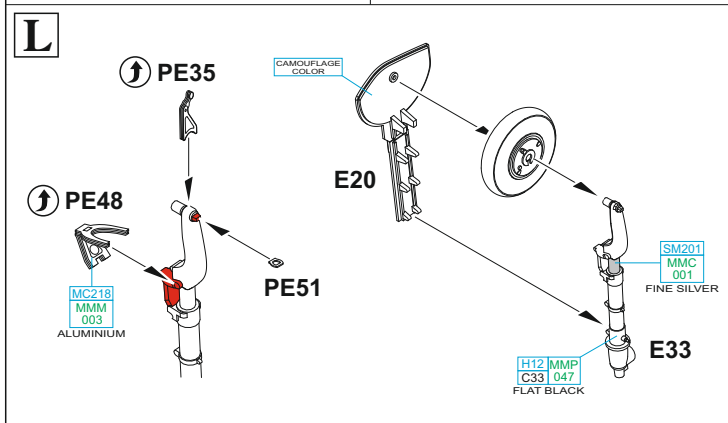
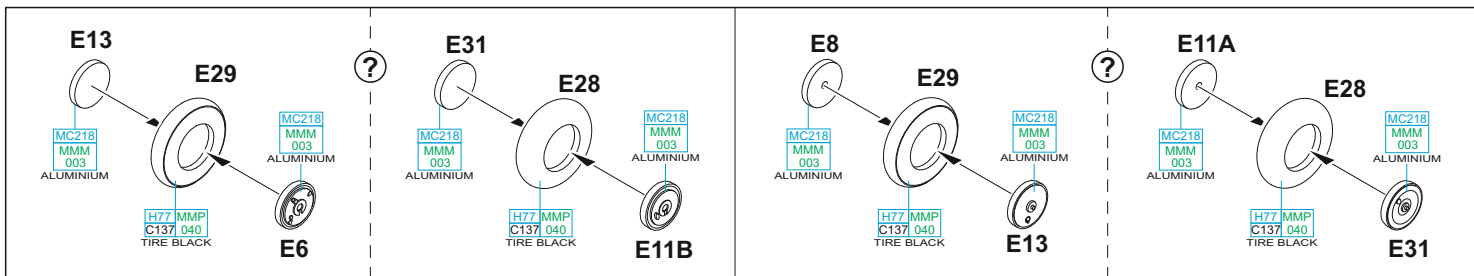

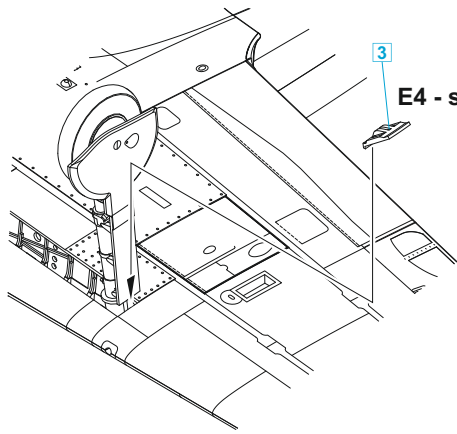

E4 - starboard ↔ E3 - port side

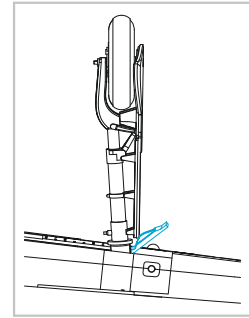

O ? MARKINGS **A, B, C, D, E, F, G, H, I, L** ONLY

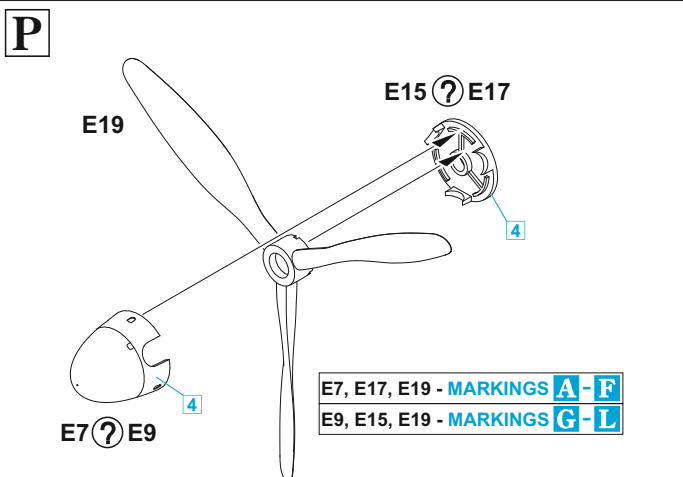
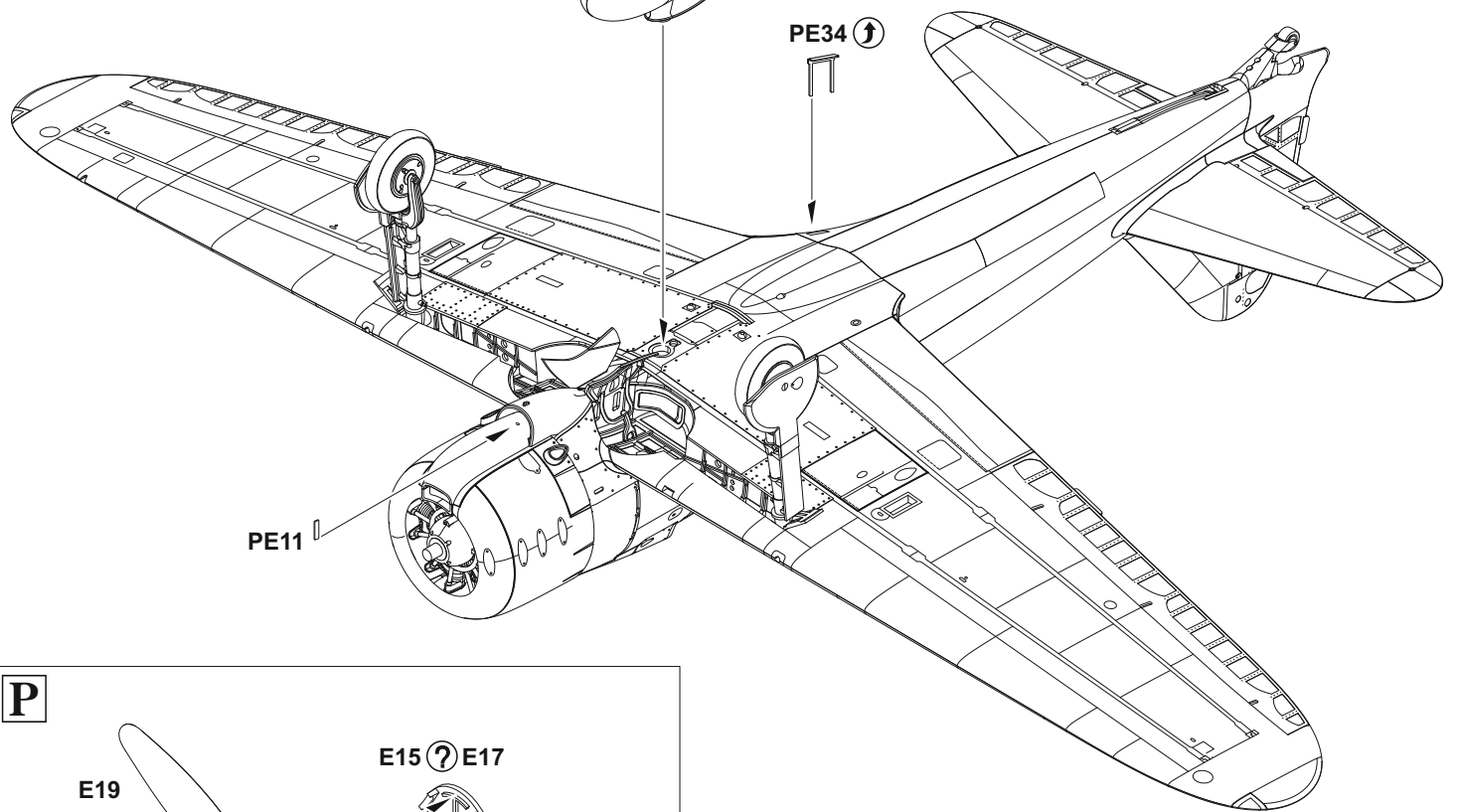
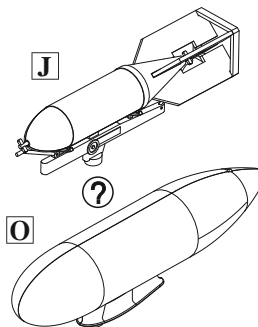
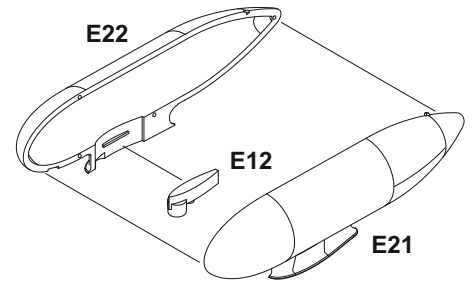

E7, E17, E19 - MARKINGS **A - F**
 E9, E15, E19 - MARKINGS **G - L**

H8	SILVER	- MARKINGS A, B, C, D, E, G, H, K, L
C8		
H24	ORANGE YELLOW	- MARKING F
C58		
MMP	RED BROWN	- MARKINGS I, J
C131	115	

OPEN
CANOPY A12 Q

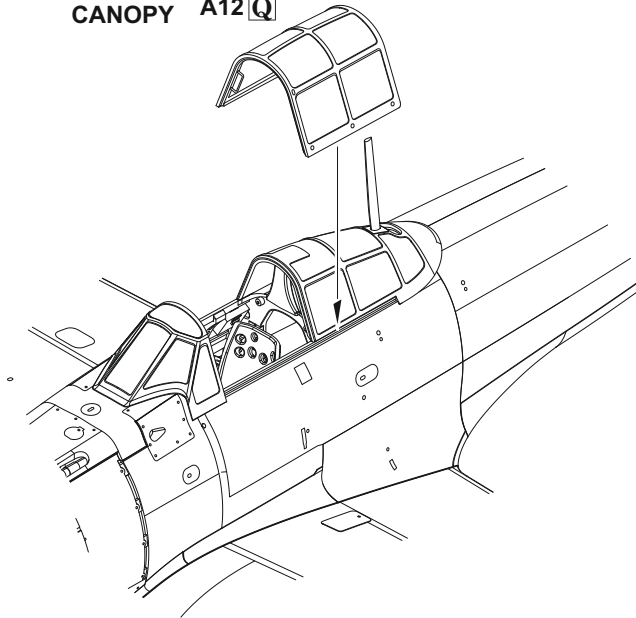

eduard
MASK
11158

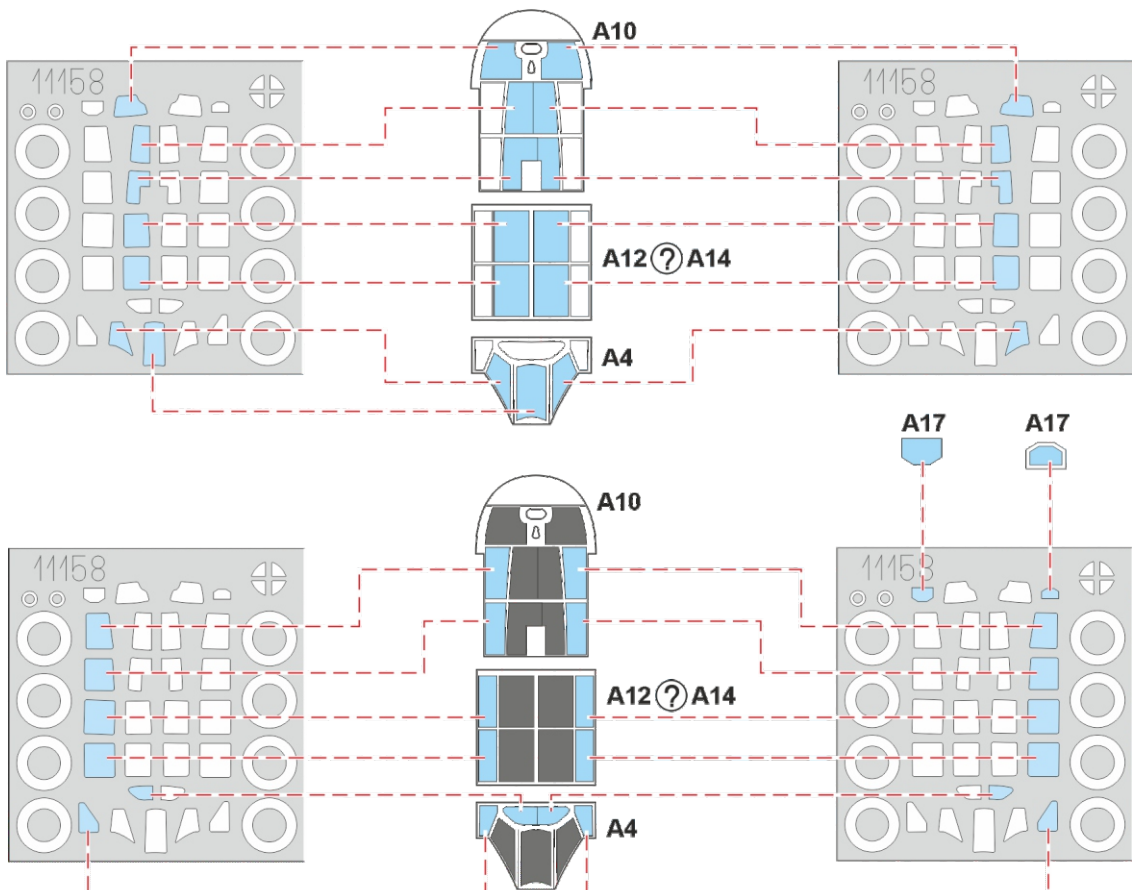
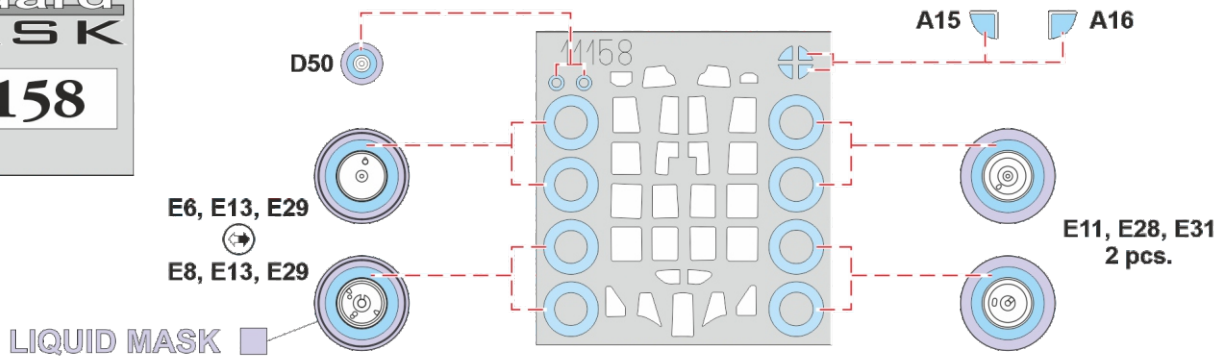

A c/n 3372, Lt. Kiku-ichi Inano, Tainan Kōkūtai, Tainan airfield, Taiwan, November 1941

This aircraft, released by Mitsubishi on October 21, 1941, became the first Zero in repairable condition to fall into Allied hands. The legendary Tainan Kōkūtai was established on October 1, 1941, at the Tainan base. Most of the unit participated in combat over the Philippines, Borneo and the Dutch East Indies. A smaller part, under the command of Lt. Kiku-ichi Inano, was transferred to French Indochina in late November and temporarily became part of 22. Kōkū Sentai HQ fighter squadron. The "V-172" fighter was Inano's personal machine. During the transfer to Saigon on November 26, Inano flew aboard a transport aircraft and his Zero was piloted by PO1c Shimezō Inoue. Inoue and his wingman with Zero "V-174" lost their bearings in poor weather and made an emergency landing on the coast of the Leichou Peninsula. Both pilots were taken prisoner by the Chinese. Inoue was repatriated after the war. He returned to his home village with shame over his capture, suffered from depression, and died in a war veterans' hospital. With great effort, the Chinese managed to transport the Zero "V-174" to Liuchow base, where they began repairs. The machine was given Chinese national insignia and number P-5016. It was also tested by pilots of the American 75th FS. In 1943, the aircraft was transported to the USA, where it received the designation EB-2, later EB-200. Lt. Inano returned to Tainan Kōkūtai in July 1942, participated in combat over New Guinea and Guadalcanal. From October 1944 served as Hikōtaichō of Tainan Kōkūtai (II) in Taiwan.

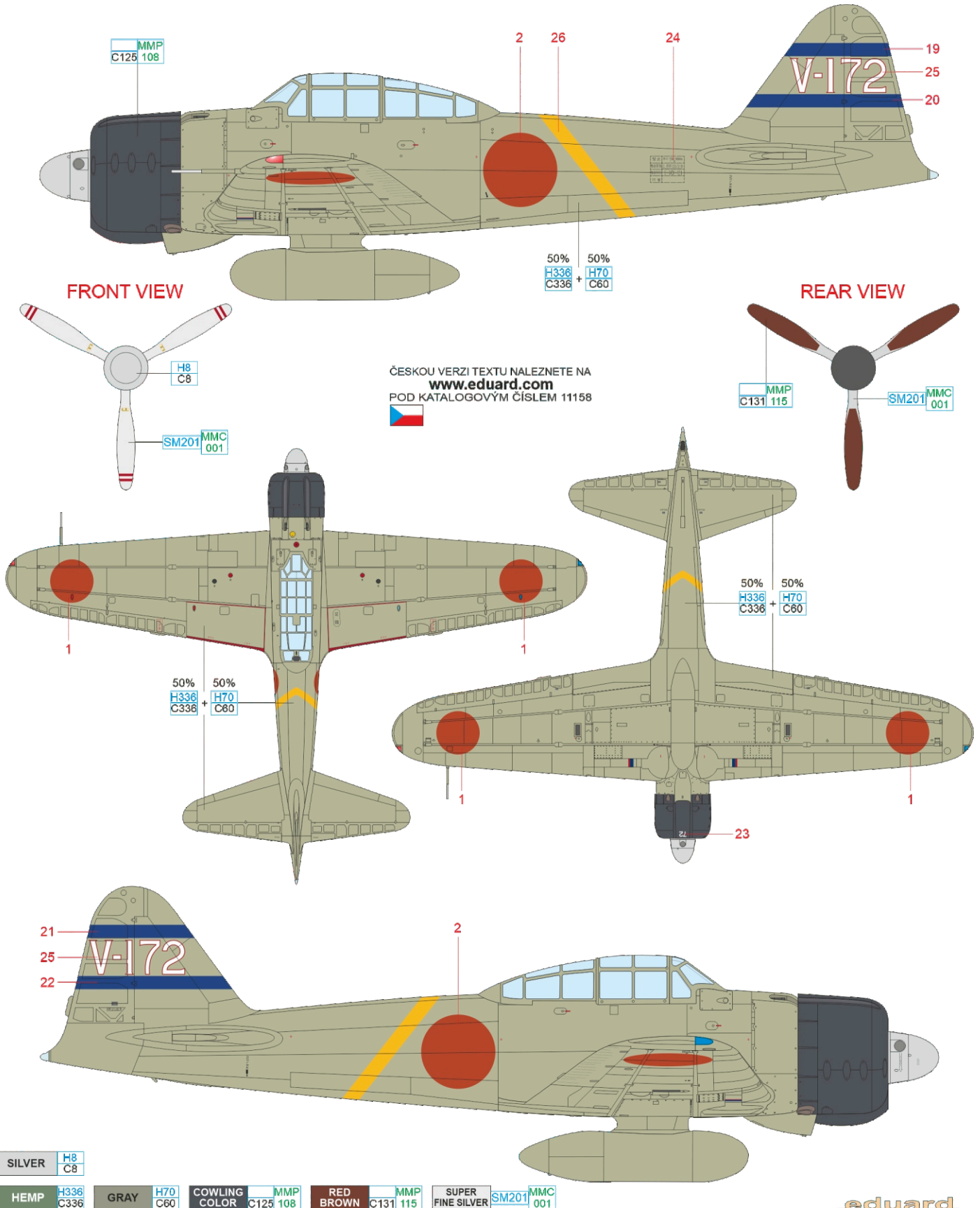

B Lt. Zenjirō Miyano, 3. Kōkūtai, Poeleti airfield, Timor, March 1942

This aircraft, manufactured by Mitsubishi, was photographed in April 1942 in Rabaul with partially repainted markings that originally belonged to Lieutenant Miyano. The bands and stripes may have been in dark blue or black color. Zenjirō Miyano served from 1939 with the 12th Kōkūtai in China and was appointed as a Buntaichō with the 3rd Kōkūtai in October 1941. He participated in the campaigns in the Philippines and the Dutch East Indies. During a raid on Broome, Australia, on March 3, 1942, Miyano attacked a Dutch civil DC-3. The pilot was Capt. Ivan Smirnov, a World War I Russian fighter ace. With one engine on fire, he managed to make an emergency landing, but the Zero pilots killed four passengers on the ground. In April 1942 Miyano was transferred to the 6th Kōkūtai, which was to be based at Midway. Part of his unit was on the way to Midway aboard the carrier Jun'yō, which participated in the attack against Dutch Harbor in the Aleutians. Miyano also participated in the raid. His unit was based at Rabaul from August 1942 and was redesignated Kōkūtai 204 in November. From March 1943 Miyano took position of Hikōtaichō. He was one of the innovators of combat tactics and was the first to introduce the finger-four formation in Japanese naval aviation. Miyano achieved a total of 16 victories and was killed on June 16, 1943, over Guadalcanal during escort of dive bombers.

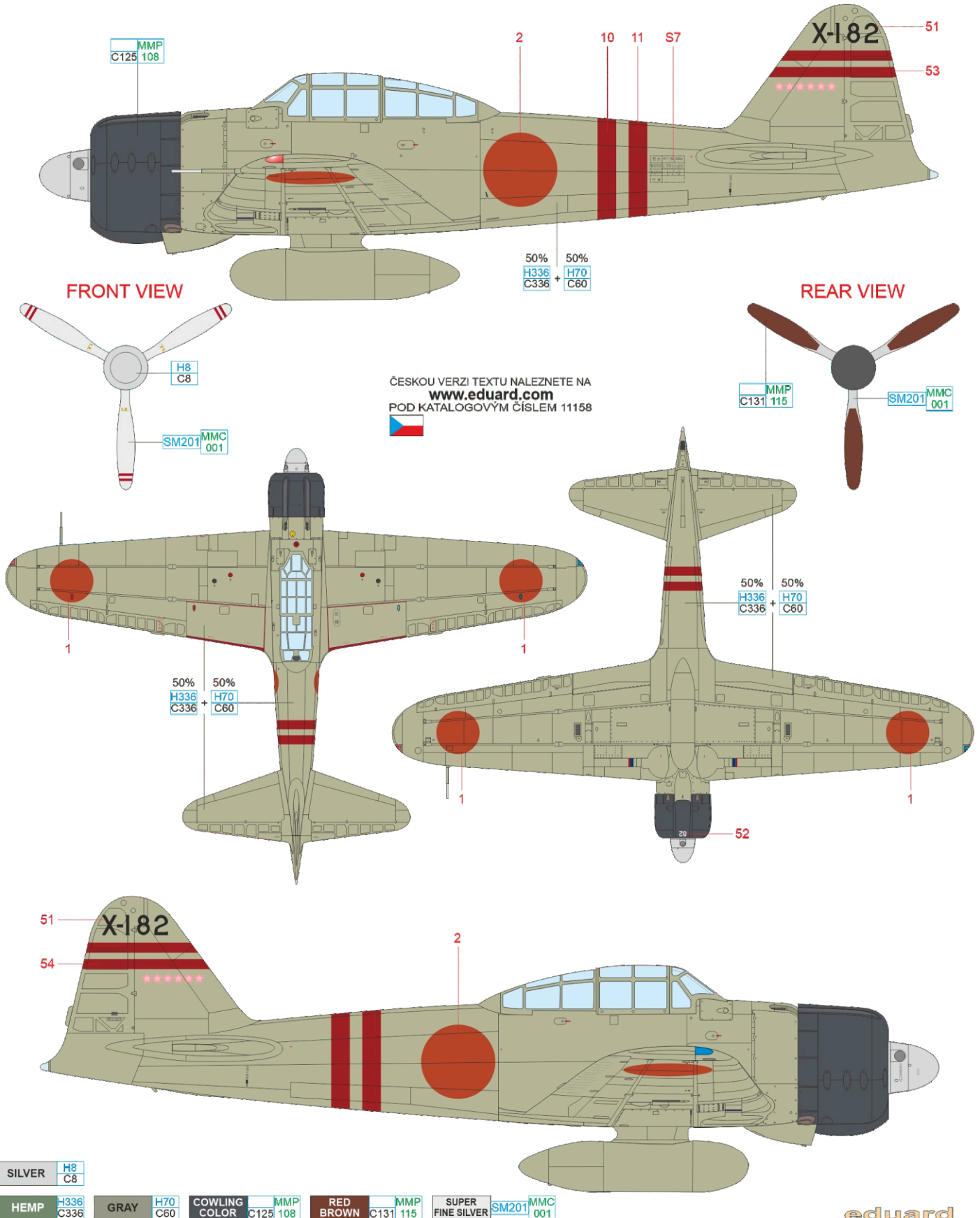

C Kaga Fighter Squadron, Kisarazu base, Japan, April 1942

In early 1942, the aircraft carrier Kaga took part in attacks on Rabaul, Kavieng, targets in New Guinea and Port Darwin. In March, her aircraft participated in attacks against ships off Java. Due to hull damage caused by a reef in early February, Kaga was undergoing repairs at Sasebo from March 22, 1942. The Mitsubishi-built "All-106" was photographed at Kisarazu in April 1942. It bears the patriotic donation inscription (Hōkoku) No. 532 and the name of the donor (Yamanobe-gō). It may be the name of a company or the donor's surname. It is likely that this aircraft participated in the Battle of Midway on June 4, 1942. Nine fighters from Kaga flew in the first attack wave, led by Lt. Iizuka. They reported twelve victories. During the exhausting combats to cover their own task force, the Kaga's fighters claimed 32 aircraft destroyed. After the carrier was hit, some of them landed aboard the HIJMS Hiryū. Two took part, as escort, in the raid on the USS Yorktown. The Kaga's Fighter Squadron lost six pilots during the battle, four of them during combat air patrol. However, elite ground personnel suffered heavy losses when the ship was sunk. Also aboard the HIJMS Kaga were fighter pilots and mechanics from the 6th Kōkūtai, who were to be based at Midway Atoll after its capture. Some of them also took part in the air battle.

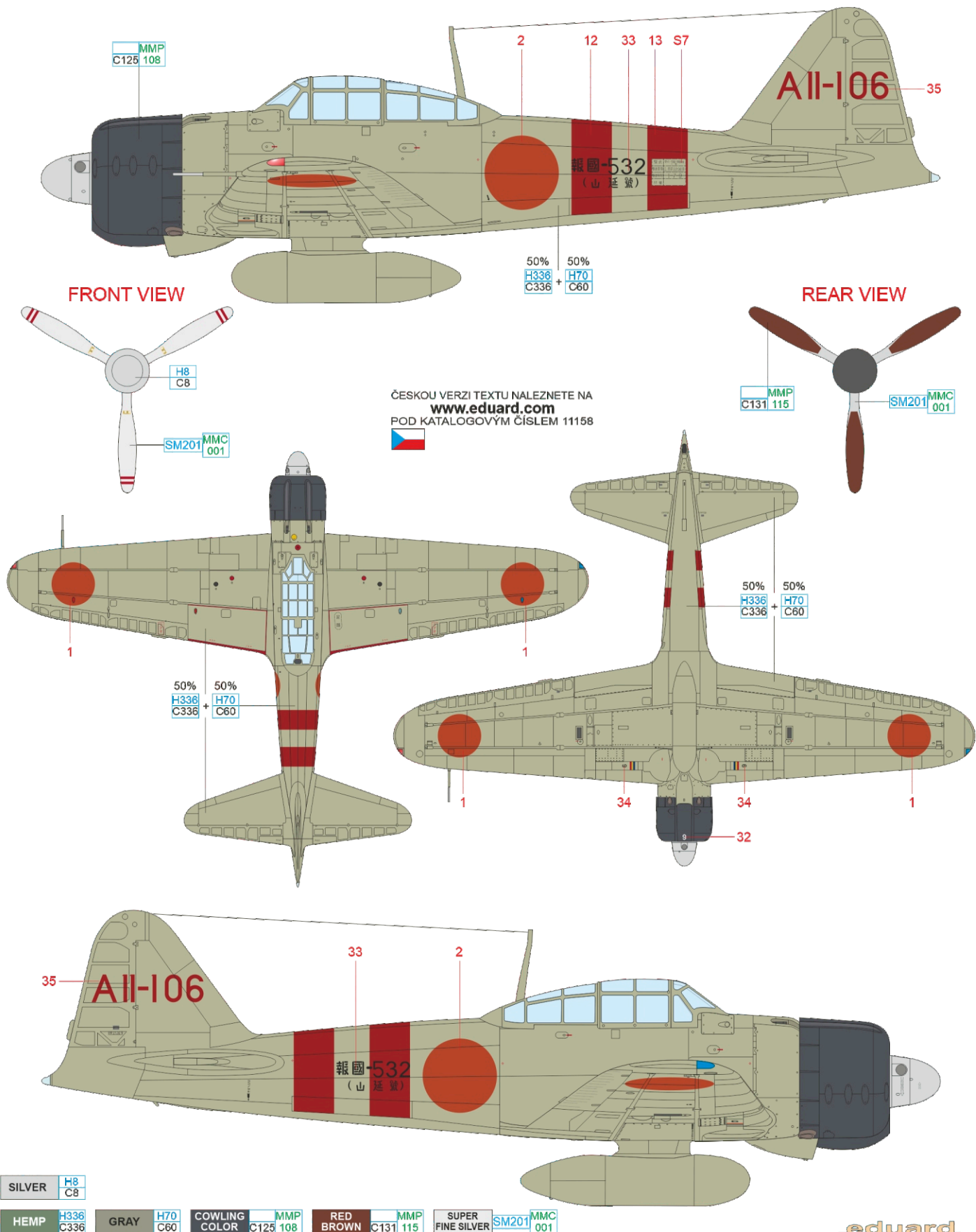

D c/n 4593, PO1c Todayoshi Koga, Ryūjō Fighter Squadron, June 1942

This aircraft was released by Mitsubishi on February 19, 1942. In late April and early May the Ryūjō Fighter Squadron received Zeros instead of older A5M „Claude“ aircraft. PO1c Koga, a veteran of 12th Kōkūtai in China, piloted “DI-108” on June 4 during the attack on the Aleutians. He was one of the two wingmen of CPO Endō. Near Egg Island they shot down Ens. Albert E. Mitchell’s Catalina of VP-42, which was carrying mail to Umnak. The burning aircraft landed on the sea and several airmen managed to get into the dingy. However, they were strafed and killed by the Japanese airmen. Koga's Zero was hit either by defensive fire from Catalina or, moments later, by ground fire. Koga attempted to land on Akutan Island, which was intended for the rescue of the Japanese airmen. The aircraft with retracted undercarriage and stopped engine overturned after touching soft marsh ground and Koga was killed. The Japanese attempted to rescue the pilot but were unable to find him due to bad weather. Five weeks later, the Zero was spotted by the crew of Lt. Williams “Bill” Thies’ Catalina. On July 5, a US Navy team reached the plane. The Americans transported the aircraft to NAS North Island in San Diego. The Zero was repaired, given a Hamilton-Standard propeller and registration number TAIC 1. It underwent intensive testing but was apparently scrapped after the war. In memory of the Ens. Mitchell and his crew, the destroyer DE-43 was christened Mitchell.

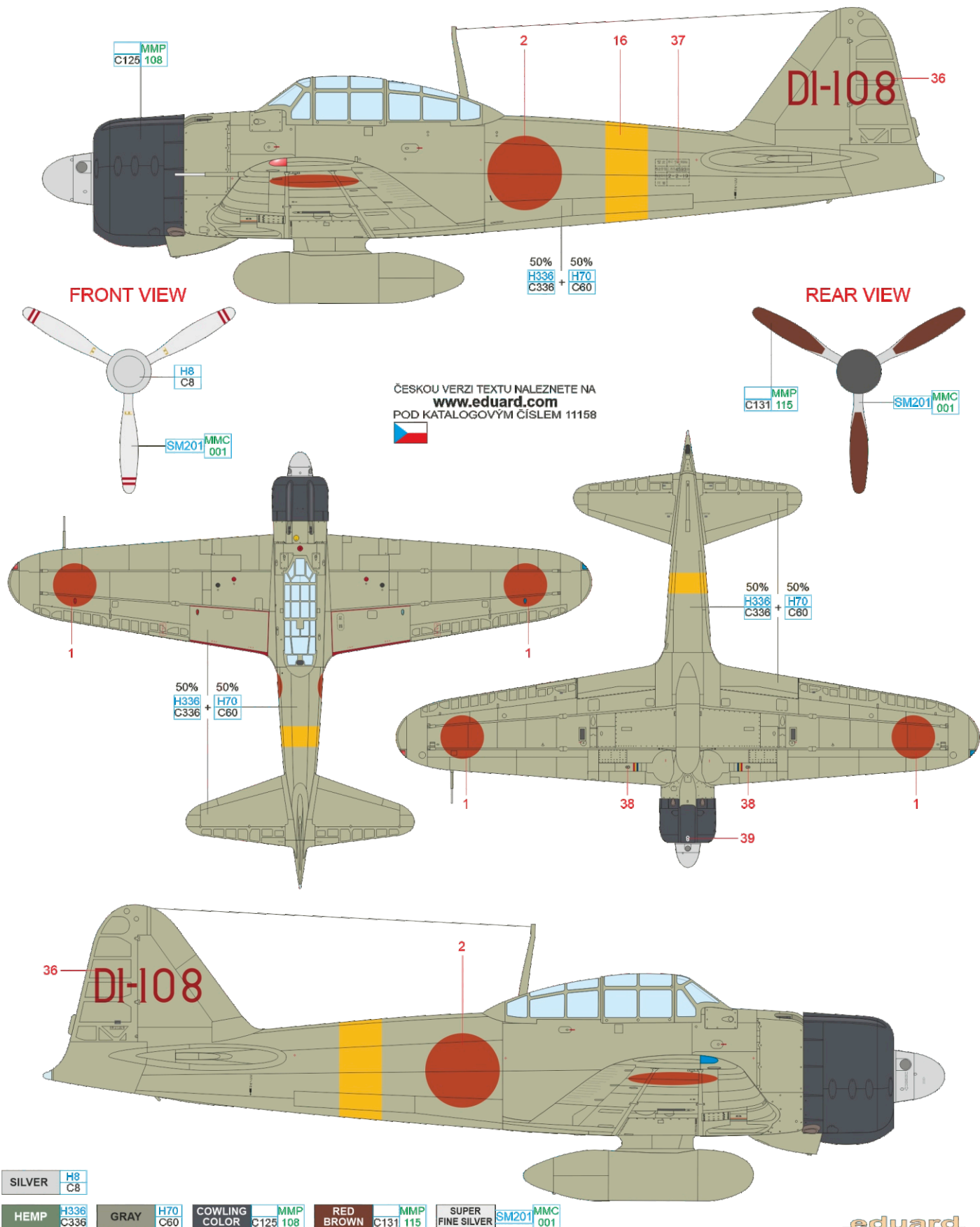

SILVER	H8 C8
HEMP	H336 C336
GRAY	H70 C60
COWLING COLOR	MMP C125 108
RED BROWN	MMP C131 115
SUPER FINE SILVER	SM201 MMC 001

This aircraft was produced by Mitsubishi on March 3, 1942. It was flown in legendary Tainan Kōkūtai by the also famous fighter aces Saburō Sakai and Hiroyoshi Nishizawa. It is believed that with this Zero, on September 13, 1942 over Guadalcanal, Shōtai leader W. O. Takatsuka was shot down in a dogfight with Wildcats from VF-5 and VMF-223. Three of his wingmen were also shot down in the same action. The wreckage of this Zero was found in 1993 in a swamp about five miles east of Henderson Field. Remnants of code and markings remained on some parts. Takatsuka had served in the IJN aviation since 1933. In the 12th Kōkūtai he was one of the fighter pilots who achieved the first victories with Zeros in aviation history on September 13, 1940. He was promoted to Warrant Officer in October 1941 and demobilized. However he was soon called back into service by the IJ Navy and from June 1942 was assigned to Tainan Kōkūtai in Rabaul. He mainly took part in the fighting over New Guinea. In total he was credited with 16 victories including three in China. Fighting with the Wildcats had already nearly proved fatal to him once. During the raid on Guadalcanal on August 7, 1942, although he claimed four victories, he flew in front of one of his opponents and immediately was hit. The victor was Thomas Rhodes of VF-6 (USS Enterprise). Takatsuka's Zero caught fire, but he managed to put it out and escape.

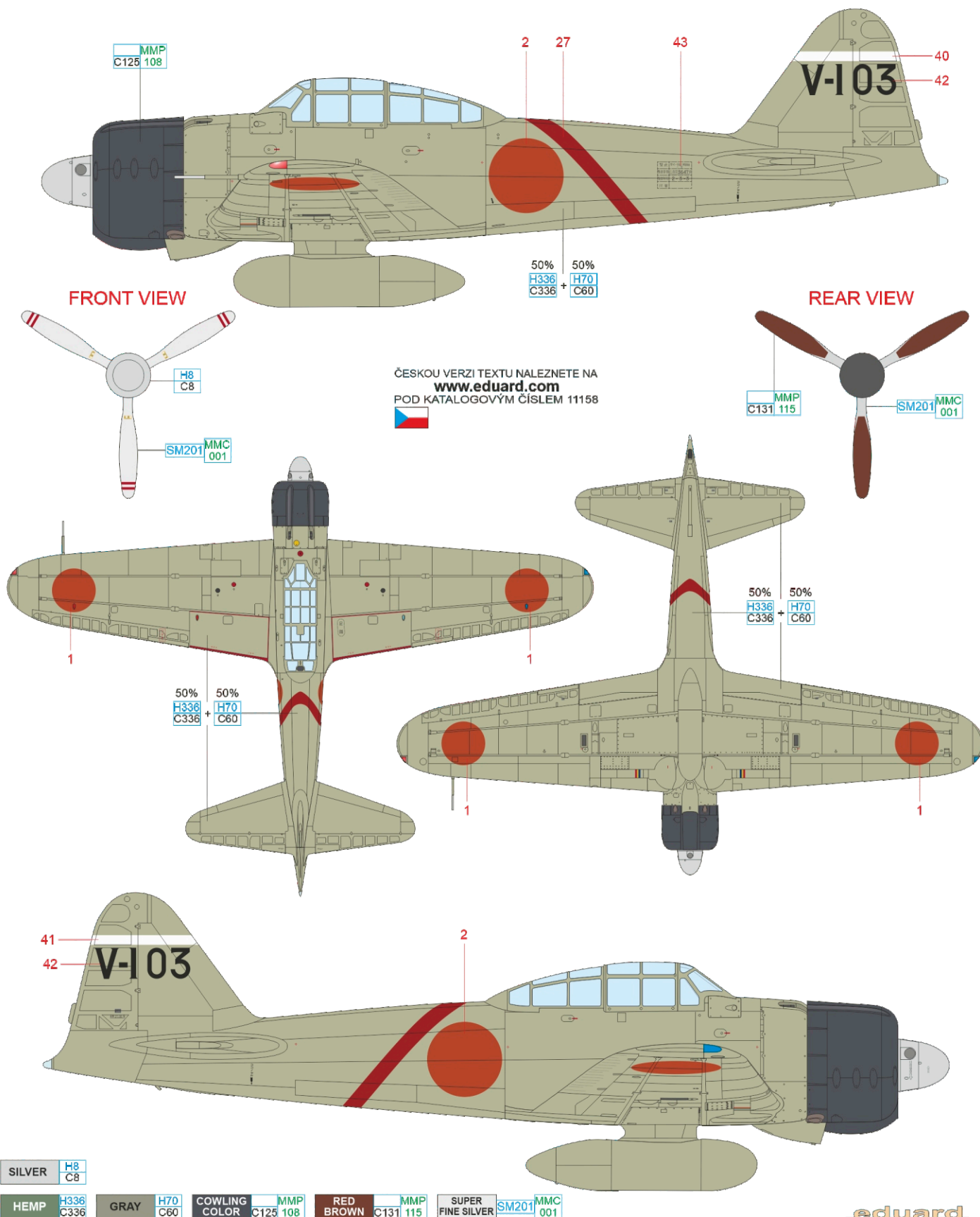

F Lt. Hideki Shingō, Shōkaku Fighter Squadron, October 1942

This aircraft manufactured by Mitsubishi carries an unusually large yellow identification stripe. Hideki Shingō (NA, 1931) served from 1934 in the Tateyama Kōkūtai, on the HIJMS Ryūjō, he became an instructor in the Yokosuka Kōkūtai, and then held Buntaichō position in the Ōmura Kōkūtai. In the second half of 1937 he fought in China with the Kaga Fighter Squadron. He then served as Buntaichō at Kanoya, Saiki, Kasumigaura, Ōita and 14th Kōkūtai. In October 1941, Shingō became Hikōtaichō in charge of training at Tainan Kōkūtai, Taiwan. He trained primarily the long-range flying. On December 8 he led 44 Zeros in an attack on the Philippine airfields of Iba and Clark Field. From April 1942 he served briefly with the 6th and Genzan Kōkūtai, then in July he became Hikōtaichō of the Shōkaku Fighter Squadron and participated in the Battle of the Eastern Solomons. At the end of August he led a detachment operating from Buka airfield. He was shot down over Guadalcanal but avoided capture. During the Battle of Santa Cruz (October 1942), he led five Zeros in the second attack wave and descended to a lower altitude in order to draw the anti-aircraft fire away from the dive bombers. He was promoted to Lt. Commander in November 1942 and in the following years served as a Hikōtaichō of Tsuiki Kōkūtai in Japan, in Indonesia and Burma with Kōkūtai 331 and Hikōtai 603, and till April 1945 with Kōkūtai 252 in Japan. After the war, he worked in the police, later joined the JSDAF, and retired in 1967 with 6,000 hours flying time and rank of Lieutenant General. Shingō-san passed away in 1982.

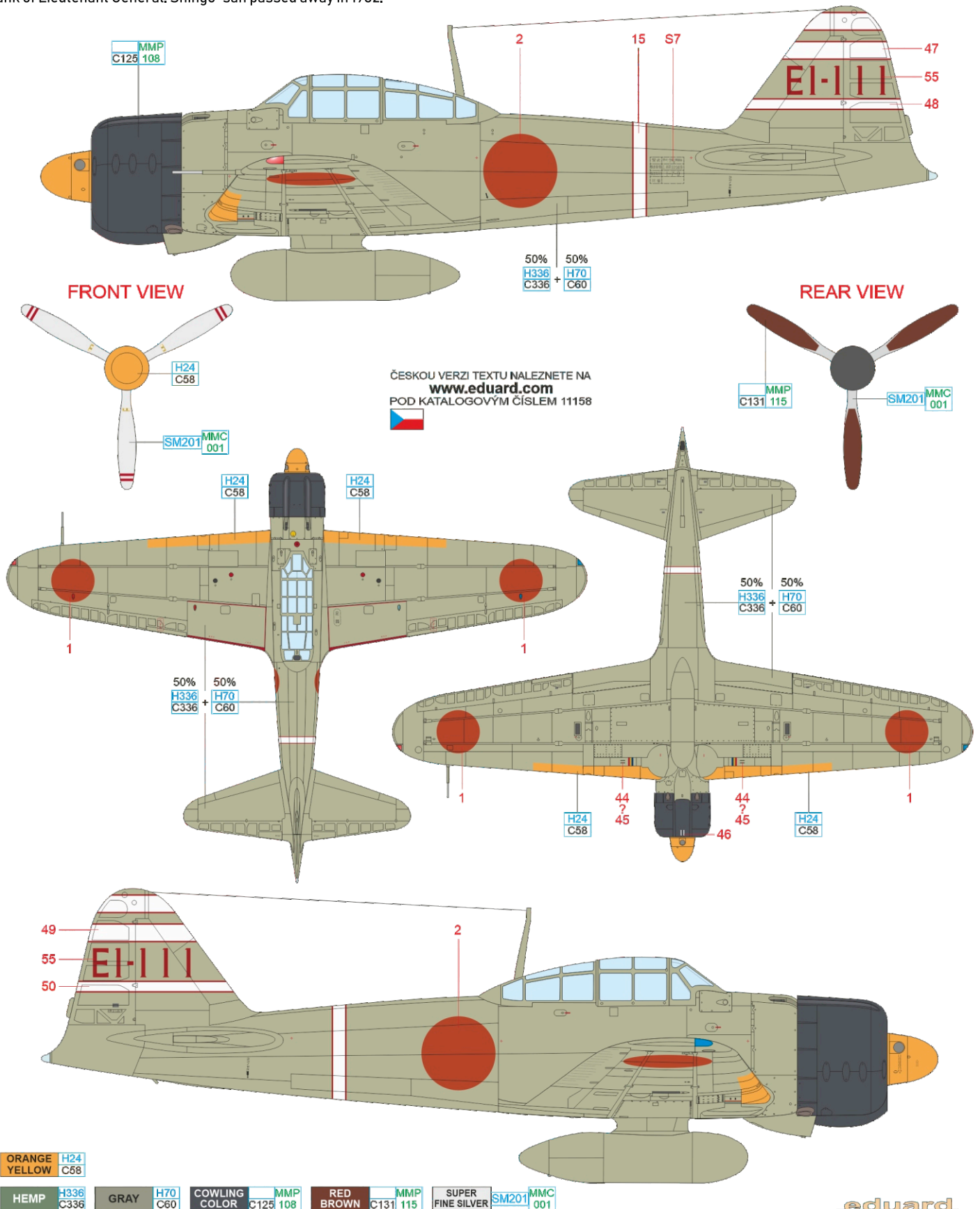

ORANGE H24
YELLOW C58

HEMP H336
C336

GRAY H70
C60

COWLING COLOR MMP
C125 108

RED BROWN C131
MMP 115

SUPER FINE SILVER SM201
MMC 001

H Jun'yō Fighter Squadron, Buin airfield, Bougainville Island, April 1943

This aircraft, manufactured by Nakajima, was photographed in April 1943 during Operation "I-gō". The code "2-1" is the designation of the 2nd Carrier Division (Kōkū Sentai), which HIJMS Jun'yō was 1st carrier. The horizontal bar below the code identifies the leader of a Shōtai, which was usually a formation of three machines. In early 1943, an improvised green paint was applied to the Zeros. The colors chosen and the execution of the paint varied from unit to unit. During this period, among the notable fighter pilots of the unit were Buntaichō Lt. Yasuhiro Shigematsu (10 v.), W. O. Tomita Atake (10 v.), and W. O. Shizuo Ishi-i (29 v.). The aircraft carrier Jun'yō was completed in May 1942, whereupon she participated in the attack against the Aleutians, took part in the Battle of Santa Cruz, and escorted army convoys bound for New Guinea. In April 1943 her Air Group operated independently from Rabaul and surrounding bases, including Buin, then withdrew to Truk. From July the Air Group was again based in Buin until September 1, 1943, when its fighter pilots were taken over by the decimated Kōkūtai 204. In November of that year the Jun'yō Air Group was reformed and in January 1944 moved again to Rabaul, where it fought for a month. Jun'yō participated also in the Battle of the Philippine Sea and then remained in Japan until the end of the war. Jun'yō Fighter Squadron scored more than 90 confirmed victories.

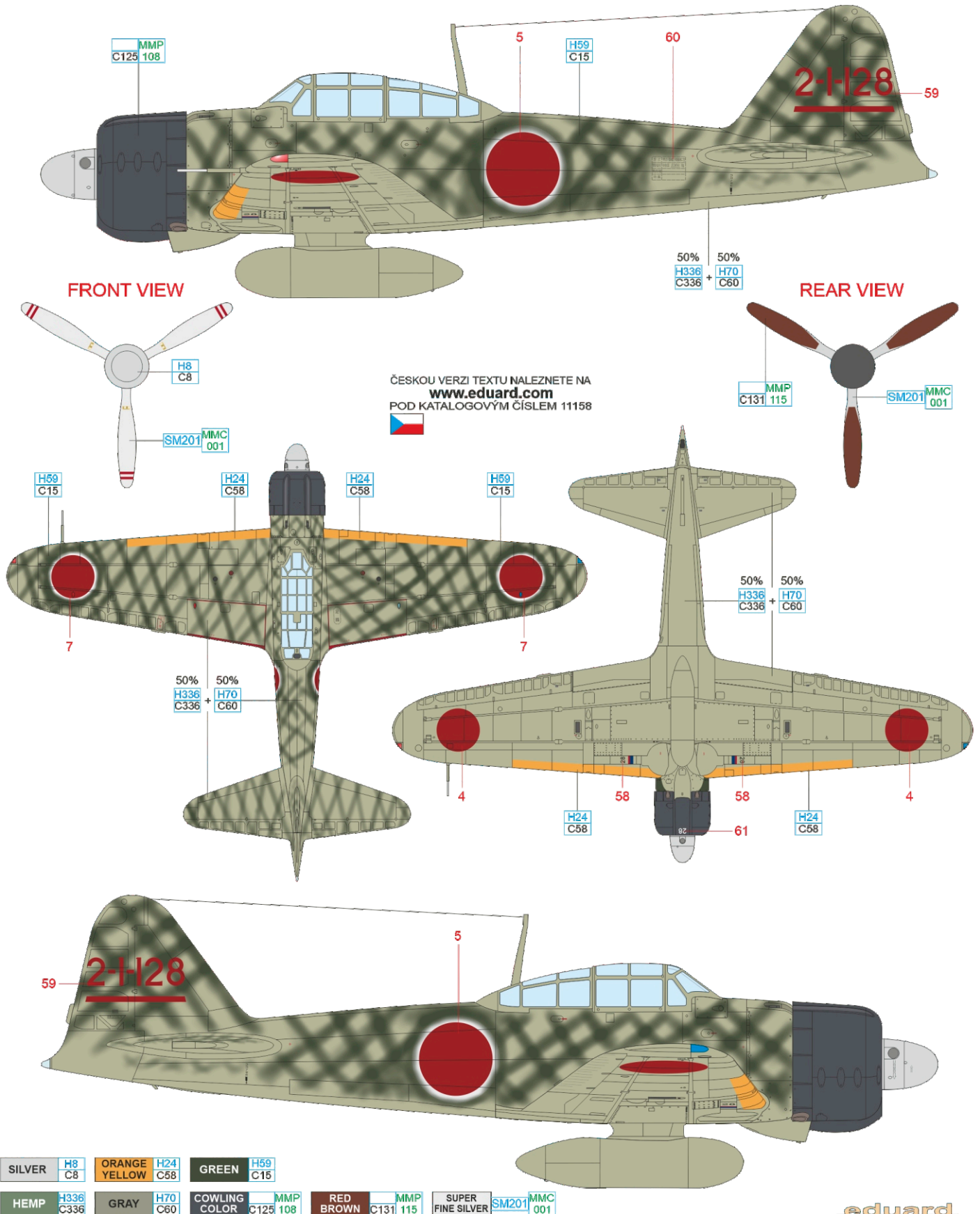

SILVER	H8 C8	ORANGE YELLOW	H24 C58	GREEN	H59 C15
HEMP	H336 C336	GRAY	H70 C60	COWLING COLOR	MMP C125 108
				RED BROWN	MMP C131 115
				SUPER FINE SILVER	SM201 MMC 001

This Nakajima-built aircraft was assigned to one of the formation leaders of Hikōtai 303, part of Kōkūtai 203, established in April 1943 from the training Atsugi Kōkūtai. At that time, this unit was armed with Zeros and "Gekkō" (Irving) night fighters. From April 1944 it defended the northern part of the Kuril Islands. From May, Kōkūtai 203 fighters clashed with American crews of Ventura and Liberator bombers. In some cases, the Americans had to make emergency landings on Soviet territory. Among the experienced aviators of this unit was Japan's most successful naval fighter pilot, Hiroyoshi Nishizawa. He served with Kōkūtai 203 from March 1944 and was assigned to its Hikōtai 303 in July. However, he did not record any victories in the Kuril Islands area. In this period Nishizawa wrote document about air combat basics due to high losses of naval aviation units and the inexperience of the new unit commanders. Since the fall of 1944, Kōkūtai 203 had seen combat at Okinawa, in the Philippines, and in Taiwan. At the time of the fighting in the Philippines, Hikōtai 303 was temporarily assigned to Kōkūtai 201. In 1945, Kōkūtai 203 was deployed in the defense of Japan, and its structure expanded up to five Hikōtais by the end of the war, with a total of 240 fighter aircraft. Kōkūtai 203 was also involved in fighter escorts of Kamikaze formations, including G4M "Betty" bombers with Ōka rocket powered aircraft.

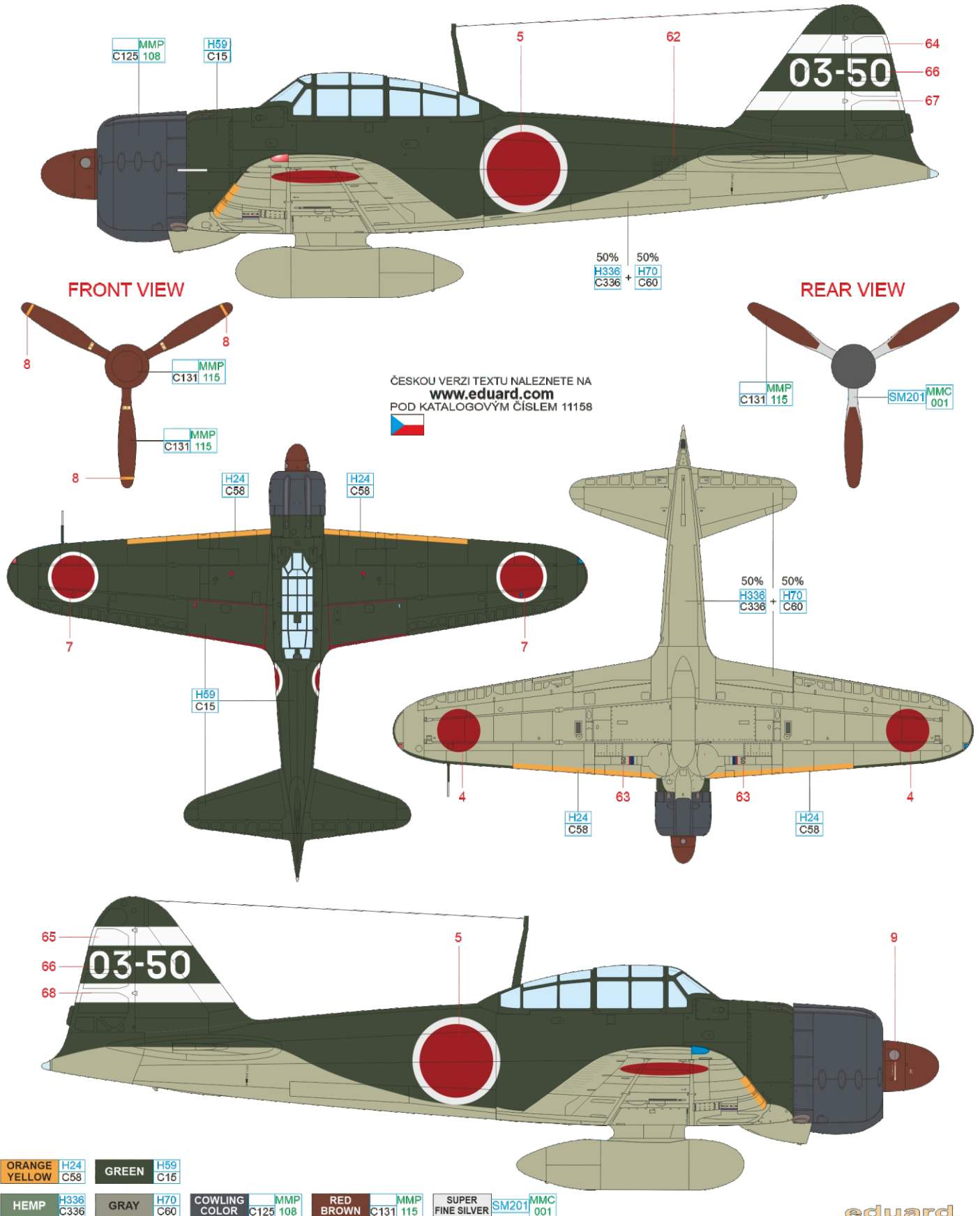

ORANGE YELLOW	H24 C58	GREEN	H59 C15	HEMP	H336 C336	GRAY	H70 C60	COWLING COLOR	MMP C125 108	RED BROWN	MMP C131 115	SUPER FINE SILVER	SM201 MMC 001
------------------	------------	-------	------------	------	--------------	------	------------	------------------	-----------------	--------------	-----------------	----------------------	---------------------

J Lt. Toshio Suzuki, Kōkūtai 601 (I), HIJMS Zuikaku, Tawi Tawi base, Philippines, June 1944

This Nakajima-built machine was piloted by Lt. Toshio Suzuki. He was in command of a squadron of eleven HIJMS Zuikaku A6M2 fighter-bombers. His unit was part of Kōkūtai 601 (I). In mid-1944, the affiliation to the Zuikaku's Carrier Air Group (Hikōkitai) was identified by the code 312 on the tail surfaces. The white numbers on the hinomaru were used during training operations and were usually chalk painted. Toshio Suzuki was born in Mitsukaidō in Ibaraki Prefecture and graduated from the Etajima Naval Academy in 1941. As a cadet, he was assigned aboard the cruiser Suzuya. After completing flight training, he was assigned to Kōkūtai 601 (I) in May 1944 and promoted to Lieutenant. Squadrons of Kōkūtai 601 (I) were divided into CAGs on boards of Taihō, Shōkaku and Zuikaku. In addition to Suzuki's fighter-bombers, Zuikaku had 24 A6M5 "Zeke" fighters, a dive-bomber squadron with 18 D4Y "Judy" and three D3A "Val", 14 B6N "Jill" torpedo bombers, and a reconnaissance squadron with several "Judy" and "Val" machines. Kōkūtai 601 (I) engaged in the Battle of the Philippine Sea on June 19 and suffered devastating losses. Lt. Suzuki led a ten-man A6M2 formation in the second wave, along with four A6M5 fighters and four "Jill" bomber crews. However they failed to find their target, and the American fighters shot down one bomber and eight A6M2s, including Suzuki's. Taihō and Shōkaku were sunk after a submarine attack, and Zuikaku was damaged by bombing.

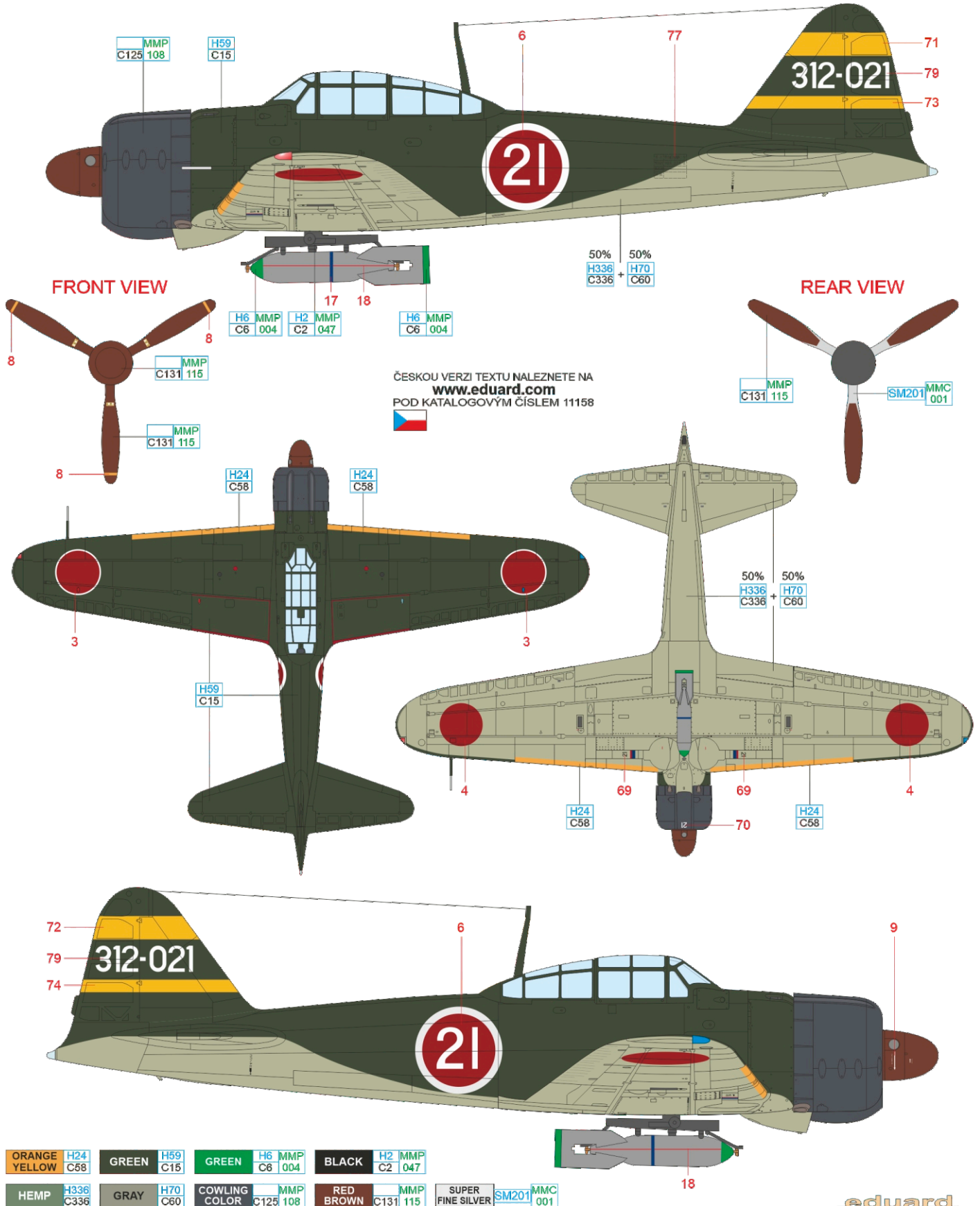

K 1st Kamikaze Tokubetsu Kōgekūtai, Shikishima-tai, Mabalacat airfield, Phillipines, October 1944

The Nakajima-built "02-888" belonged to first official Kamikaze unit in the history of the Japanese Naval Air Force. As part of the 1st Kamikaze Tokubetsu Kōgekūtai, a total of nine groups of airmen were organized, mostly from Kōkūtai 201. Their target was Task Force Taffy 3 during the Battle of Leyte Gulf. The Shikishima unit was named after the poetic term used for the island of Yamato (Honshū), or also old Japan. Its commander was Lt. Yukio Seki. He was born in 1921 and graduated from the Naval Academy in 1941. He first served on the battleship Fusō, then experienced the Battle of Midway on the seaplane carrier Chitose. In 1943 he completed basic flight training and later received training on carrier bombers. In September 1944, he was assigned in the Philippines to Kōkūtai 201, which specialized in skip bombing with A6M fighters. The unit suffered heavy losses during September and October. Replacements were taken over in Mabalacat from other units, including Hikōtai 602 (Kōkūtai 381), from which machine "02-888" appears to have originated. On October 25, Lt. Seki led one of seven groups of Zero pilots equipped with bombs who sacrificed themselves in an attack on American vessels. Seki's fighter escort was provided by legendary fighter pilot Hiroyoshi Nishizawa of Kōkūtai 203. Lieutenant Seki or one of his wingmen hit the aircraft carrier USS St. Lo, which sank after 30 minutes. Of the 889 crew members, 113 were killed or missing and about thirty others died of their injuries.

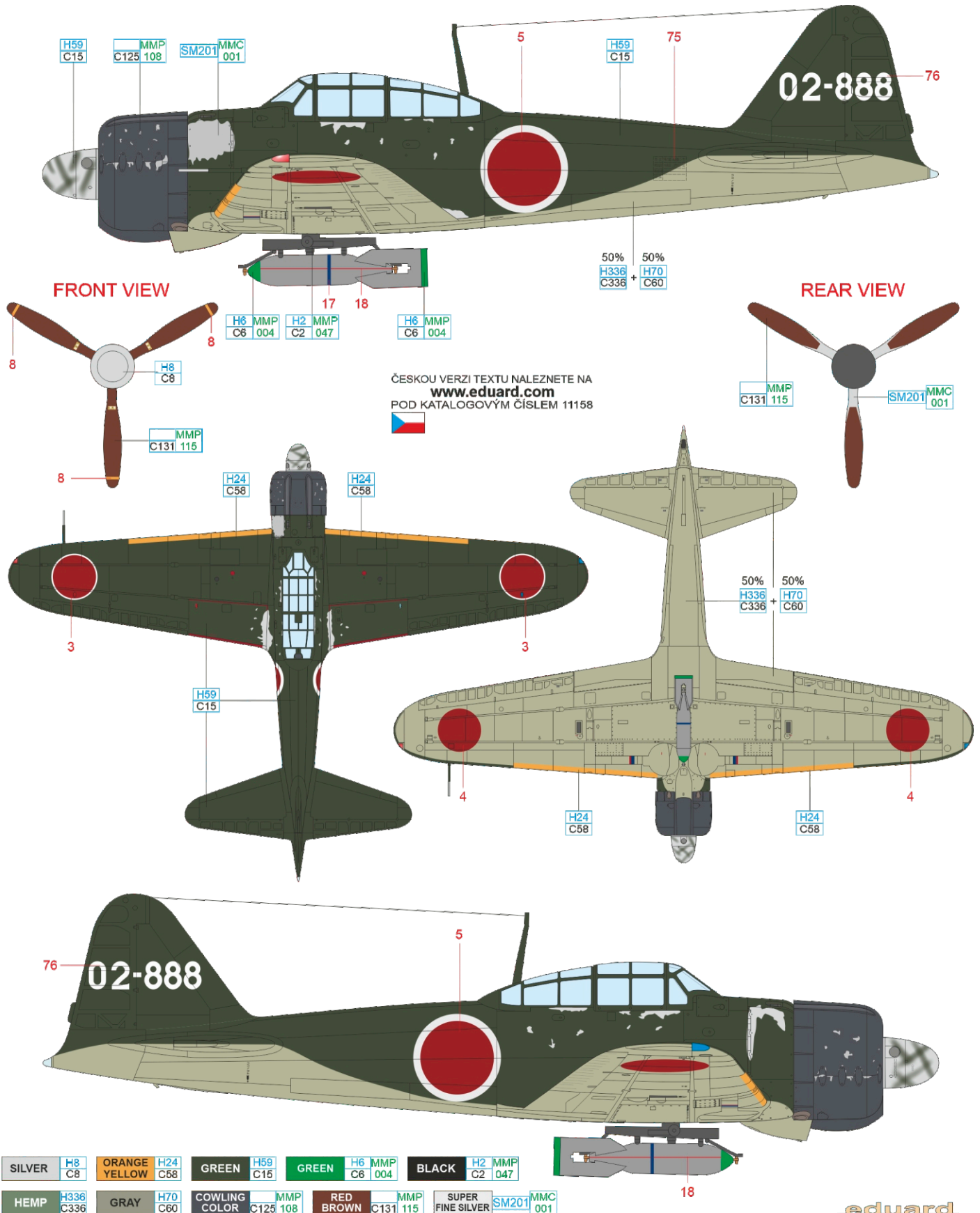

Ōita Kōkūtai, Ōita Airport, Japan, early 1944

This Nakajima-built machine served with the training unit Ōita Kōkūtai. It bore orange paint on the undersurfaces and had a non-standard dark green paint on the undercarriage covers and part of the undersurfaces. The characters in the Katakana "O" and "Ta" are the unit markings. The machine carries warning stencils on both sides of the fuselage. The vertical rectangle reads "87A" as a warning that the aircraft uses 87 octane fuel instead of the 91 octane fuel used in Sakae 12 engines in combat units. In the horizontal rectangle is the warning "būsuto" (boost). It draws attention to the lower boost pressure limit associated with 87 octane fuel. Exceeding it threatened engine damage. The late production A6M2s from Nakajima may have had the engine cowling painted black instead of antiglare blue-black. The outer fuselage sections below the cockpit canopy and canopy frames may have been painted in interior green or camouflage dark green. The Ōita Kōkūtai was established in 1938 and was used for training until March 1944. Many famous aviators passed through its ranks. Combat veterans were also assigned to this unit as instructors, such as Kaneyoshi Mutō, who served with the unit after his combat duty in China and five victories of his total 28.

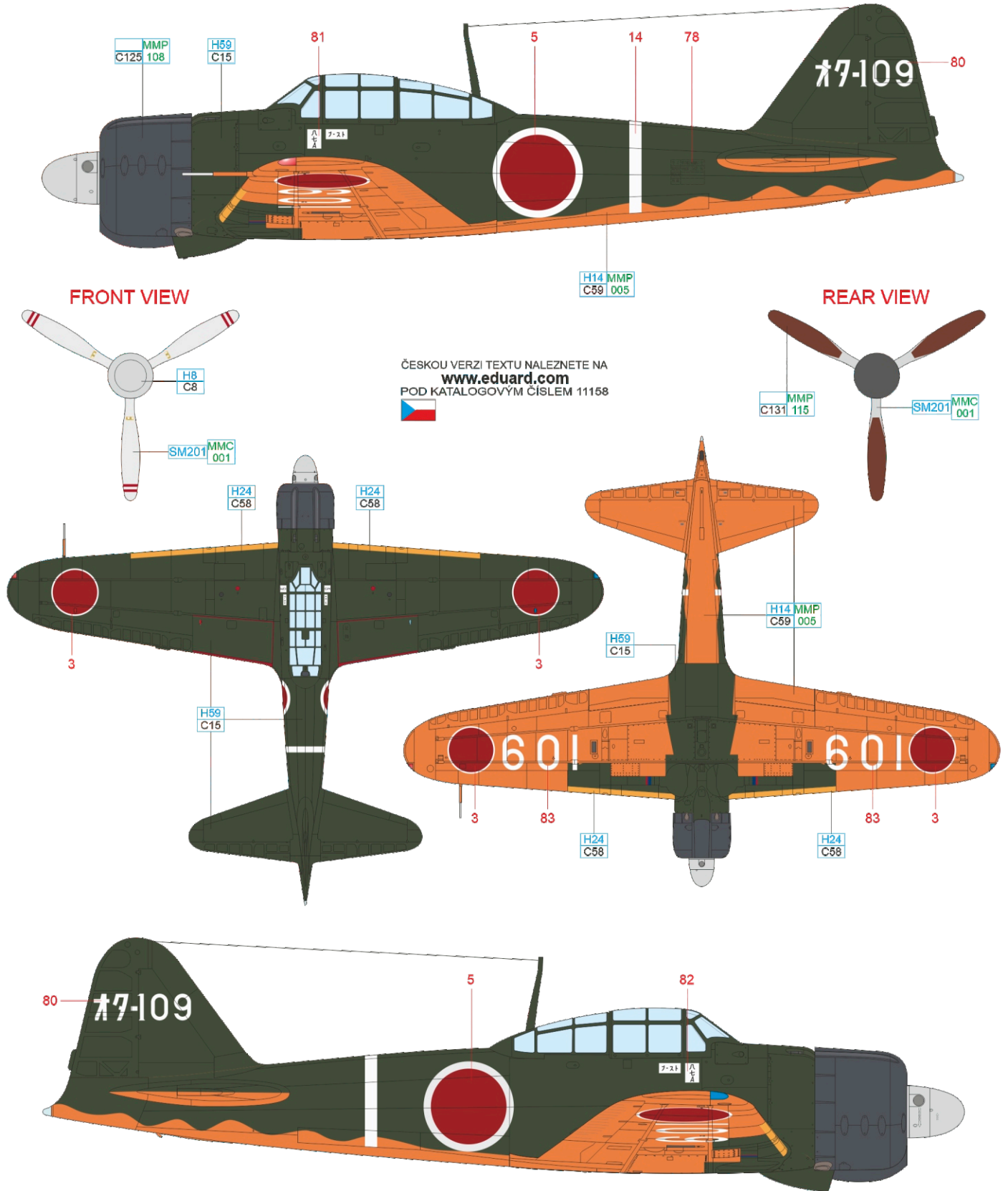

ČESKOU VERZI TEXTU NALEZNETE NA
www.eduard.com
 POD KATALOGOVÝM ČÍSLEM 11158



SILVER	H8 C8	ORANGE	H24 C58	GREEN	H59 C15
ORANGE	H14 MMP C59 005	COWLING COLOR	MMP C125 108	RED BROWN	MMP C131 115
				SUPER FINE SILVER	SM201 MMC 001

A6M2 Zero Type 21

STENCILING POSITIONS

* - STENCILS SIGNED WITH * ARE FOR MARKINGS G, H, I, J, K, L (NAKAJIMA BUILT AIRCRAFT)

