



KOREA

INSTRUCTION SHEET

1/48

11161-NAV1

MUSTANGS IN KOREA



photo: private collection

On Sunday, June 25, 1950, at 0400 hours, the army of the Democratic People's Republic of Korea set out to attack its southern neighbor, the Republic of Korea. The heavily armed North Korean army had overwhelming superiority over its southern neighbor. US forces had withdrawn from Korea a year earlier, and the USA provided South Korea with insufficient armament and virtually no air force.

After the WWII, the P-51D/K Mustangs became the USAAF's standard fighter aircraft. They were redesignated F-51 in 1948, shortly after the US Air Force was established as a separate branch of the US armed forces (on September 18, 1947). Mustangs were serving worldwide, but their replacing by new jets was accelerating towards 1950. The units based in Japan were no exception, the USAF units had already completed their conversion to the jets there at the time of the North Korean attack. These jets may have been faster, but lacked the long range of Mustang. And it was a real problem when it came to air attacks carried out from Japan bases. The distance from Itazuke AB, where the 8th FBG was based, to Seoul was about 370 mi (600 km), meaning F-80s could spend just a handful minutes of activity over the target zone before settling for return. Apart of aforementioned 8th FBG, there were also other units stationed in Japan: 35th FIW (Yokota), 49th FBG (Misawa) and 51st FIW (Naha, Okinawa). All of them were part of the USAF Far Eastern Air Force (FEAF), consisting of the 5th, 13th, and 20th Air Forces. The FEAF commander, Lt. Gen. George E. Stratemeyer, was on leave at the time of the attack, so the burden of the first wartime decisions was on his deputy, Maj. Gen. Earl E. Partridge.

Return of the Mustang

It was obvious from the very first days of the Korean war that the allied forces could not do much without air support. South Korea's air force was virtually non-existent, while North Koreans had at least 122 combat aircraft, including Il-10s and Yak-9s. The F-80s were not suitable for immediate move to the Korean theater, while their insufficient range limited combat operations from Japan. The FEAF command therefore concluded that Mustangs, which were capable of operating in the harsh conditions of frontline airfields would be a solution. Another type under consideration was the F-47 Thunderbolt, but these aircraft were no longer available in sufficient numbers. There were still about 800 Mustangs in the US on the other hand but only a few dozen remained in

Japan, especially at Johnson (now Iruma) AB, where they were awaiting scrapping. The FEAF command therefore spared them and requested delivery of more F-51s from the United States as soon as possible. A total of 79 Mustangs were provided by the units of National Guard, with another 66 obtained from the McClelland Air Force Base warehouses.

The aircraft carrier USS Boxer departed Alameda, CA, on July 14, with 145 Mustangs on board. Under the command of Captain John B. Moss, she managed to make the trip to Japan in a record time of eight days and seven hours.

Bout One, Dallas Squadron and the ROKAF

A call was sent out to all 5th Air Force units on June, seeking for ten volunteer pilots to train South Korean ROKAF pilots on the F-51 in Korea while providing limited air support to UN ground forces as well. One hundred ground personnel were to move with them to Korea. The unit was designated Bout One and Major Dean Hess became its commander. The unit was equipped with ten F-51s, previously earmarked for training of South Korean pilots in Japan.

First of the Mustangs to be moved to Korea departed Japan on the afternoon of June 29 and arrived at Suwon (K-13) right at the time North Korean Il-10s attacked the airfield. Within moments four Il-10s went down and the Mustang air combat score was opened in Korea, witnessed directly by the Supreme Allied Commander, General Douglas MacArthur, who held a briefing at the Suwon base at the time. Six more Mustangs with freshly painted ROK yin-yang roundels flew to Korea from Itazuke on July 2 with ROKAF pilots at controls. With their arrival, the Bout One was united in Taegu (K-2) and almost immediately, its pilots began training and combat operations.

General Stratemeyer also ordered the 13th AF, based at Clark Air Base in the Philippine Islands, to select pilots within the 18th FBG who had until recently been flying F-51s. From these, a squadron was formed that became known as the Dallas Squadron. Thirty Mustangs were readied for them at Johnson AFB.

RF-51Ds of 45th TRS flew reconnaissance missions at or near the front. The camera openings are clearly visible.

photo: U.S. Air Force



photo: U.S. Air Force

Capt. Daniel "Chappie" James in front of F-51 of 12th FBS at Taegu. He later rose through the ranks to become the first African-American four-star general in the USAF.

A flight of the ROKAF F-51s of No. 1 Squadron



photo: U.S. Air Force

These were the last remaining Mustangs in Japan prior to the USS Boxer arrival. At Taegu, the Dallas Squadron „absorbed“ Bout One and formed the 51st FS(P). The unit had flown 426 combat sorties by the end of July and the Mustangs quickly gained recognition; General Timberlake, for example, stated that one Mustang from Taegu was the equivalent of four F-80s operating from Japan. This was in spite of the many difficulties Mustang pilots faced. They were flying in unfamiliar terrain, they didn't even have the necessary maps, and most importantly, they lacked qualified forward air controllers. The soldiers selected for this task were neither experienced nor sufficiently qualified, and their guidance often confused men in the cockpits. Therefore, pilots themselves were sent to ground units to ensure increased accuracy of ground guidance.

South Korean pilots trained within the Bout One later formed No. 1 Squadron ROKAF, which gradually gained in experience. As late as early April 1951, the unit still had only eight Mustangs at its disposal, but by the end of the month there were already 21 of them and newly trained pilots were joining the squad. In October 1951, the 10th FG ROKAF was formed, and its composition allowed the South Koreans to operate independently. The first such a mission took place on October 11, 1951. After the end of the war, some Mustangs were left in South Korea by USAF and ROKAF used them until 1957.

Regular USAF units

The first standard USAF unit to give up its F-80s for reconverting to the F-51s was the 40th FIS of the 35th FIG. Its pilots flew missions over Korea from Johnson AB until mid-July when it moved to the Pohang base, followed by another component of the 35th FIG, the 39th FIS on August 10. The 8th FBG converted to Mustangs during August and September 1950. By then, its pilots were flying F-80s and F-51s from Japan. A group consisting of the 35th FBS, 36th FBS, and 80th FBS began their operations from Korean territory in October and late November 1950. By December, pilots of the 8th FBG had already begun flying F-80s again.

The components of the 49th FBG, the 7th FBS, 8th FBS and 9th FBS begun their operations in the Korean War with F-51s and F-80s in June 1950. They flew the F-51s just briefly, returning to their F-80s, which they operated from Taegu Base as early as late September. It was very different with 18th FBG, as the unit kept their Mustangs until January 1953. The components of the 18th FBG were the 39th FIS, the 12th FBS, the 67th FBS, and the South African No. 2 Squadron. Apart of the F-51s flying CAS missions, pilots of photo-reconnaissance Mustangs were also putting their efforts to support Allied forces. It was the 45th TRS, the only component of the 67th TRW flying Mustangs. They used F-51s for armed vi-

sual reconnaissance and RF-51s for photo reconnaissance. The Wing Commander, Colonel Karl I. Polifka, renowned recce pilot, was killed on July 1, 1951, while conducting a reconnaissance mission near Kaesong. Polifka's F-51 was hit by anti-aircraft fire. Pilot managed to bail out, but his parachute did not open...

The UN Allies with Mustangs

Two more squadrons were equipped with Mustangs, the No. 77 Squadron RAAF (Australian) and No. 2 Squadron SAAF (South African). The No. 77 Squadron was part of the FEAF with base at Iwakumi. Aussies started their missions with an unfortunate incident on July 3, when they were directed by mistake to attack a train with South Korean and American troops. The mistake cost life 28 Koreans and one American. Shortly after, two high-profile losses hit the Squadron. First on June 7, when Squadron Leader Graham Strout was killed, two days later No. 77 Squadron lost their commanding officer, W/Cdr. Louis T. Spence during a napalm attack on Angang. On February 21, 1951, the first F.8 Meteors appeared with No. 77 Squadron, gradually replacing the Mustangs.

The No. 2 Squadron SAAF was formed on September 5, 1950, under the command of S/Ldr Servaas van Breda Theron, a veteran of WWII fighting in Africa with No. 112 Squadron. South African „Flying Cheetahs“ became part of the 18th FBW and after conducting 10,373 combat flights they were rearmed with F-86Fs during late 1952.

The indispensable

Mustangs became absolutely indispensable in the early stages of the Korean War, although they were far from the ideal aircraft for strafing missions. Because of the radiator located under the fuselage due to long coolant lines they were much more vulnerable to the ground fire than, say, F-4U Corsairs deployed by US Marines.

The Mustangs' vulnerability to ground fire took a harsh toll during the war, with F-51s accounting for more than half of total air losses in some time periods. In April 1951, for example, 13 Shooting Stars, 2 Thunderjets, and 25 Mustangs were shot down by the enemy ground fire. The F-51s were gradually replaced by modern jets but fought in the ROKAF ranks until the end of the war.

Mustang pilots flew 62,607 operational sorties in Korea, dropped 12,909 tons of bombs and fired 183,034 rockets. In combat, 341 Mustangs were lost, and total losses reached 474 aircraft. In return, Mustang pilots destroyed tens of thousands of ground targets and also achieved sixteen aerial kills, all of them piston-engined aircraft. In addition they destroyed also eight enemy aircraft on the ground, damaged seven MiG-15s and recorded two probable kills of these jets.

ATTENTION



UPOZORNĚNÍ



ACHTUNG



ATTENTION



注意



Carefully read instruction sheet before assembling. When you use glue or paint, do not use near open flame and use in well ventilated room. Keep out of reach of small children. Children must not be allowed to suck any part, or pull vinyl bag over the head.



Před započítím stavby si pečlivě prostudujte stavební návod. Při používání barev a lepidel pracujte v dobře větrané místnosti. Lepidla ani barvy nepoužívejte v blízkosti otevřeného ohně. Model není určen malým dětem, mohlo by dojít k požití drobných dílů.

INSTRUCTION SIGNS

* INSTR. SYMBOLS

* INSTRUKTION

* SINNBILDEN

* SYMBOLES

* 記号の説明

OPTIONAL
VOLBABEND
OHNOUTSAND
BROUSITOPEN HOLE
VYVRTAT OTVORSYMETRICAL ASSEMBLY
SYMETRICKÁ MONTÁŽREMOVE
ODŘÍZNOUTREVERSE SIDE
OTOČITAPPLY EDUARD MASK
AND PAINT
POUŽIT EDUARD MASK
NABARVIT

PARTS



DÍLY



TEILE



PIÈCES



部品

PLASTIC PARTS

A > 2 pcs.

82100 A

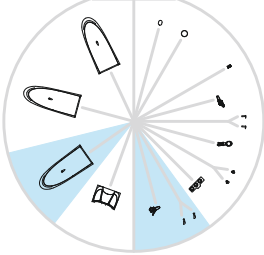

B > 2 pcs.

82100 B

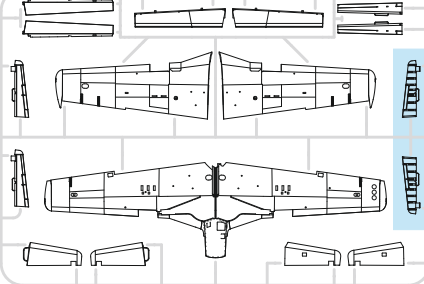

D >

82100 D

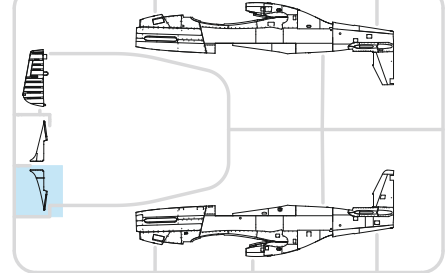

E >

82100 E

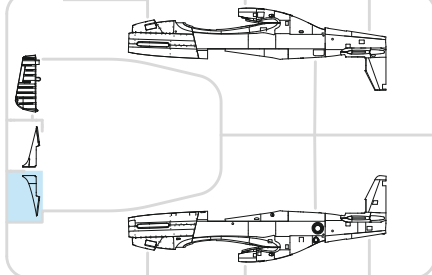

F > 2 pcs.

82100 F

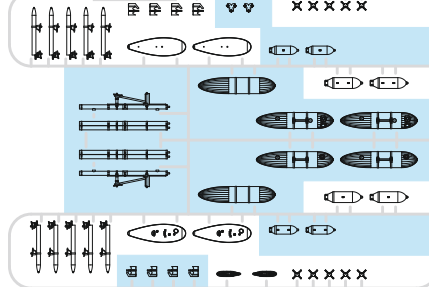

G > 2 pcs.

82100 G

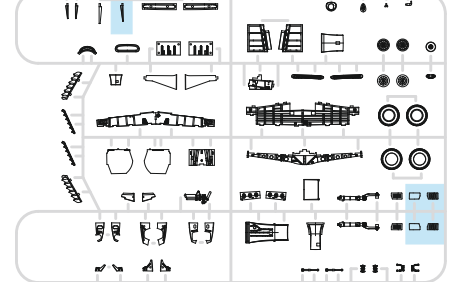

H > 2 pcs.

82100 H

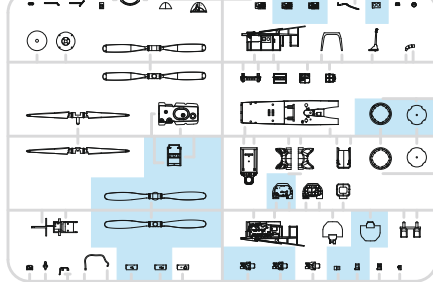

J > 2 pcs.

82100 J

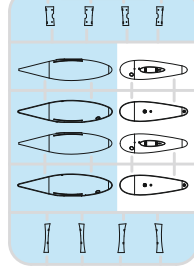
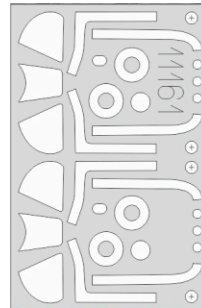
eduard
MASK

PE - PHOTO ETCHED DETAIL PARTS

2 pcs.

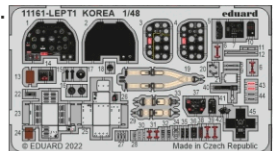

2 pcs.

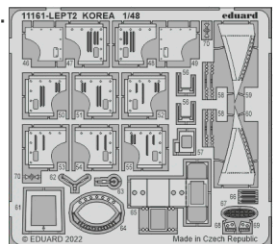

-Parts not for use. -Teile werden nicht verwendet. -Pièces à ne pas utiliser. -Tyto díly nepoužívejte při stavbě. - 使用しない部品

COLOURS



BARVY



FARBEN



PEINTURE



色

GSI Creos (GUNZE)		MISSION MODELS	
AQUEOUS	Mr.COLOR	PAINTS	
H1	C1	MMP-001	WHITE
H8	C8		SILVER
H12	C33	MMP-047	FLAT BLACK
H15	C65		BRIGHT BLUE
H27	C44		TAN
H37	C43		WOOD BROWN
H47	C41	MMP-012	RED BROWN
H52	C12	MMP-091	OLIVE DRAB
H58	C351	MMP-059	INTERIOR GREEN
H77	C137	MMP-040	TIRE BLACK
H90	C47		CLEAR RED
H91	C48		CLEAR YELLOW

GSI Creos (GUNZE)		MISSION MODELS	
AQUEOUS	Mr.COLOR	PAINTS	
H94	C138		CLEAR GREEN
H316	C316	MMP-104	WHITE
H326	C326		BLUE
H327	C327	MMP-101	RED
H329	C329		YELLOW
	C352		YELLOW CHROMATE
Mr.METAL COLOR		METALLICS	
MC214		MMM-001	DARK IRON
Mr.COLOR SUPER METALLIC		METALLICS	
SM201		MMC-001	SUPER FINE SILVER
SM203			SUPER IRON

A SOME OF F-51/RF-51 RETAINED WARTIME INTERIOR GREEN COLOR WHILE OTHER AIRCRAFT GOT OVERALL BLACK FINISH INSTEAD

1 = 90% + 10%
 H58 MMP C351 059 INT. GREEN H12 MMP C33 047 FLAT BLACK

PE24 - MARKINGS **A, B, H, I, J**
 H50 - MARKINGS **C, D, E, F, G**

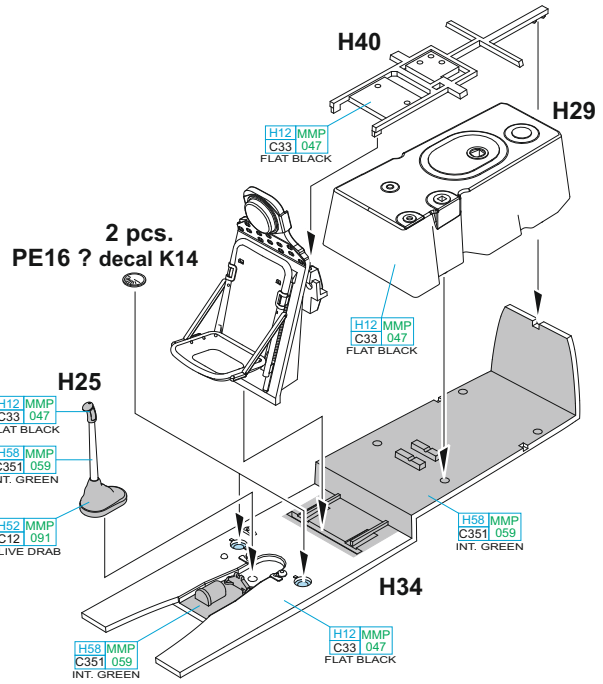
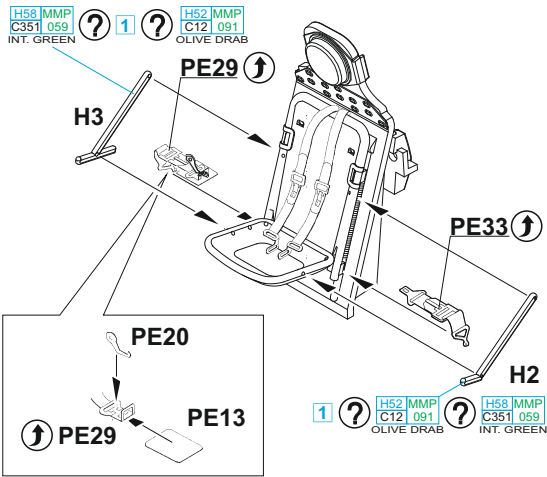
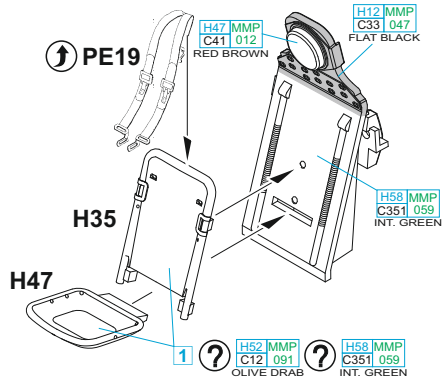
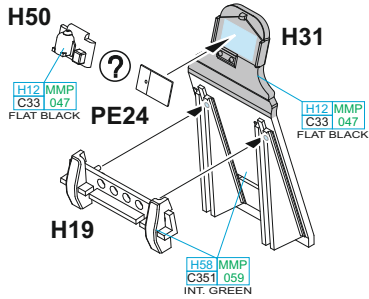

? MARKINGS **B, E, I, J**

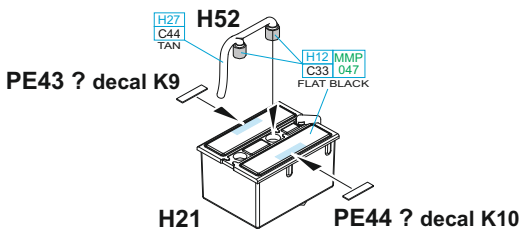

H23, H63 - MARKING **B** ONLY

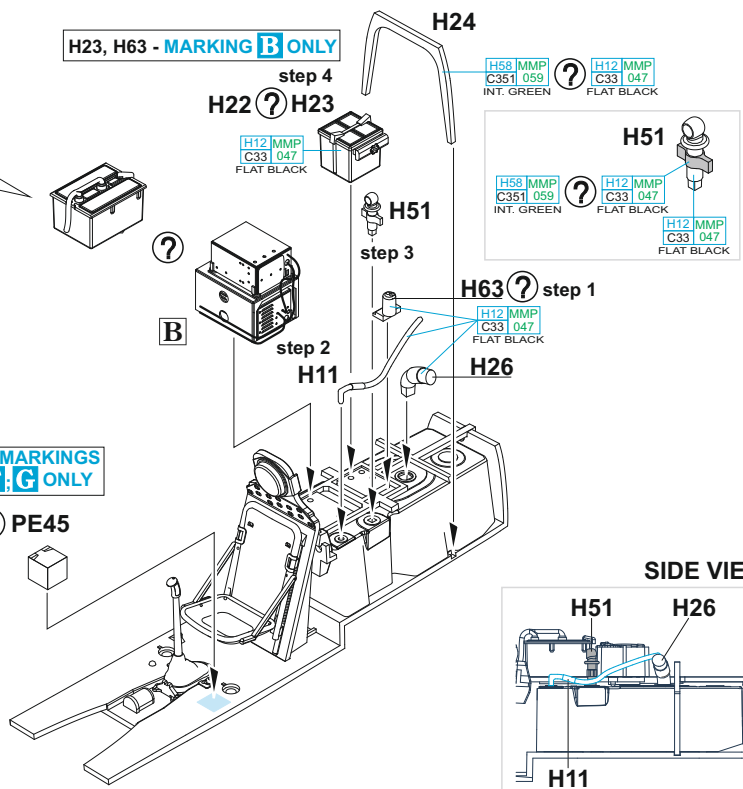

B MARKINGS **A, C, D, F, G, H**

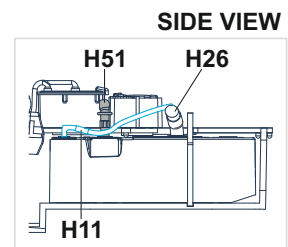
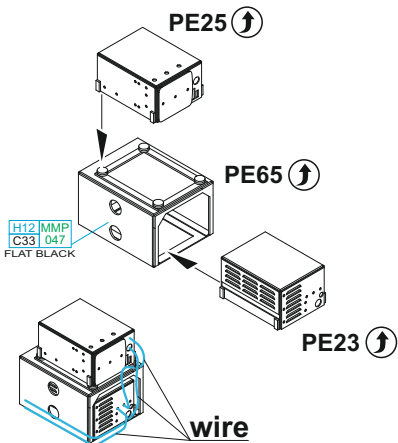

MARKINGS B, D, G, H, J ONLY

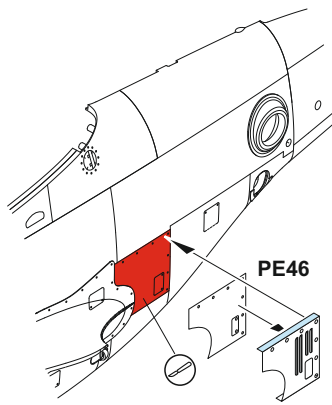

PE47, 48 - MARKINGS G, J ONLY
 PE50, 51 - MARKING H ONLY
 PE52, 55 - MARKING D ONLY
 PE53, 54 - MARKING B ONLY

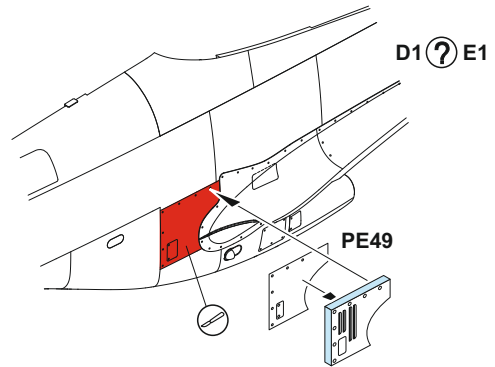

PE48 PE50 PE52 PE53

C

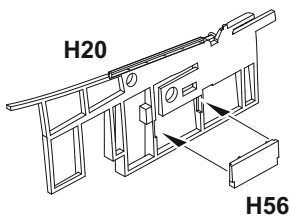

C

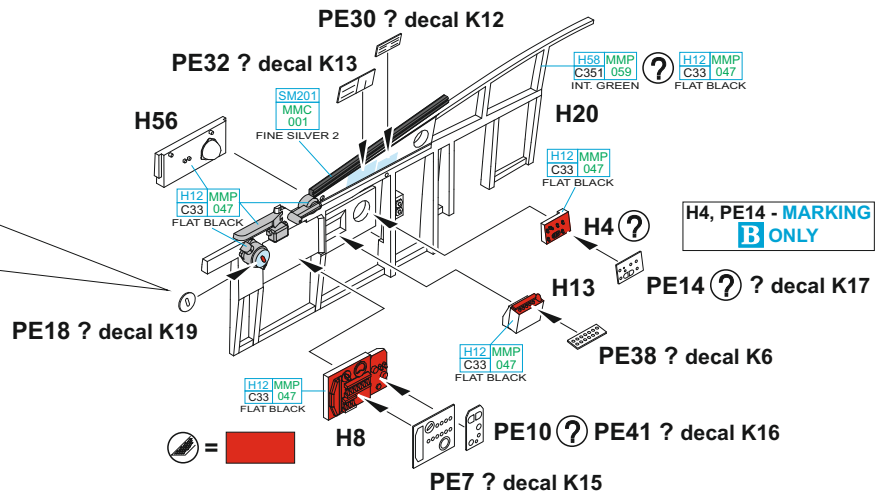

D

D1 - MARKINGS A, B, C, D, H, I, J
 E1 - MARKINGS E, F, G

MARKINGS B, C, D, E, F, G, H, I, J ONLY

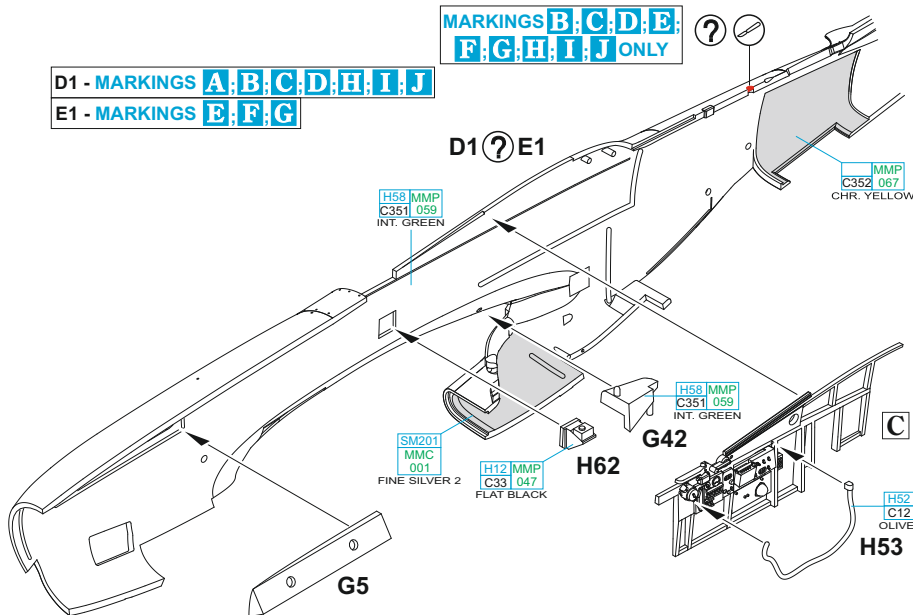

MARKING B ONLY

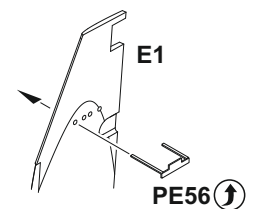
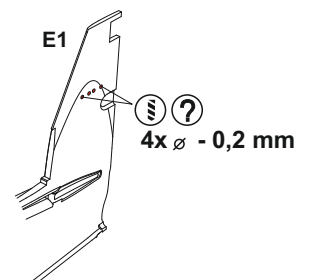

MARKING B ONLY

E

D2 - MARKINGS A; B; C; D; H; I; J

E2 - MARKINGS E; F; G

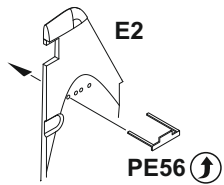

MARKINGS B; C; D; E; F; G; H; I; J ONLY

4x $\varnothing - 0,2$ mm

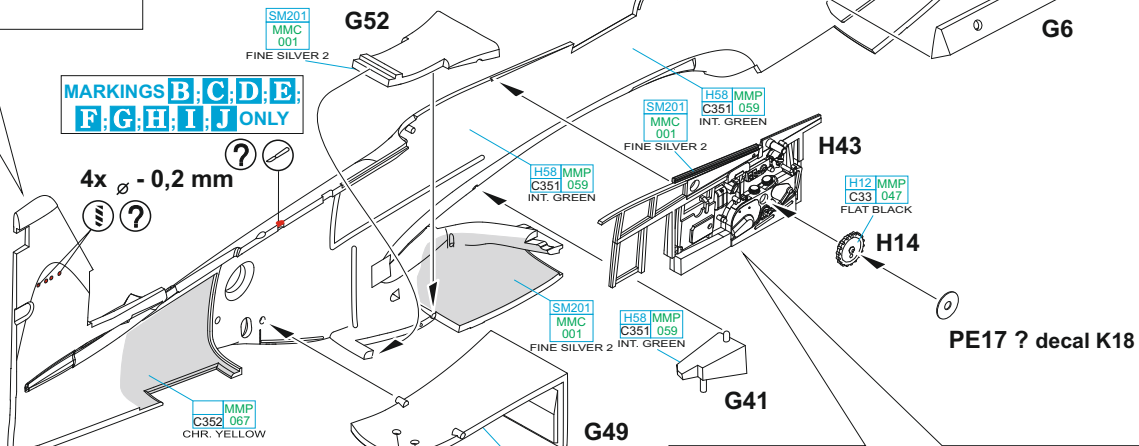

PE30 ? decal K12

PE32 ? decal K13

PE22

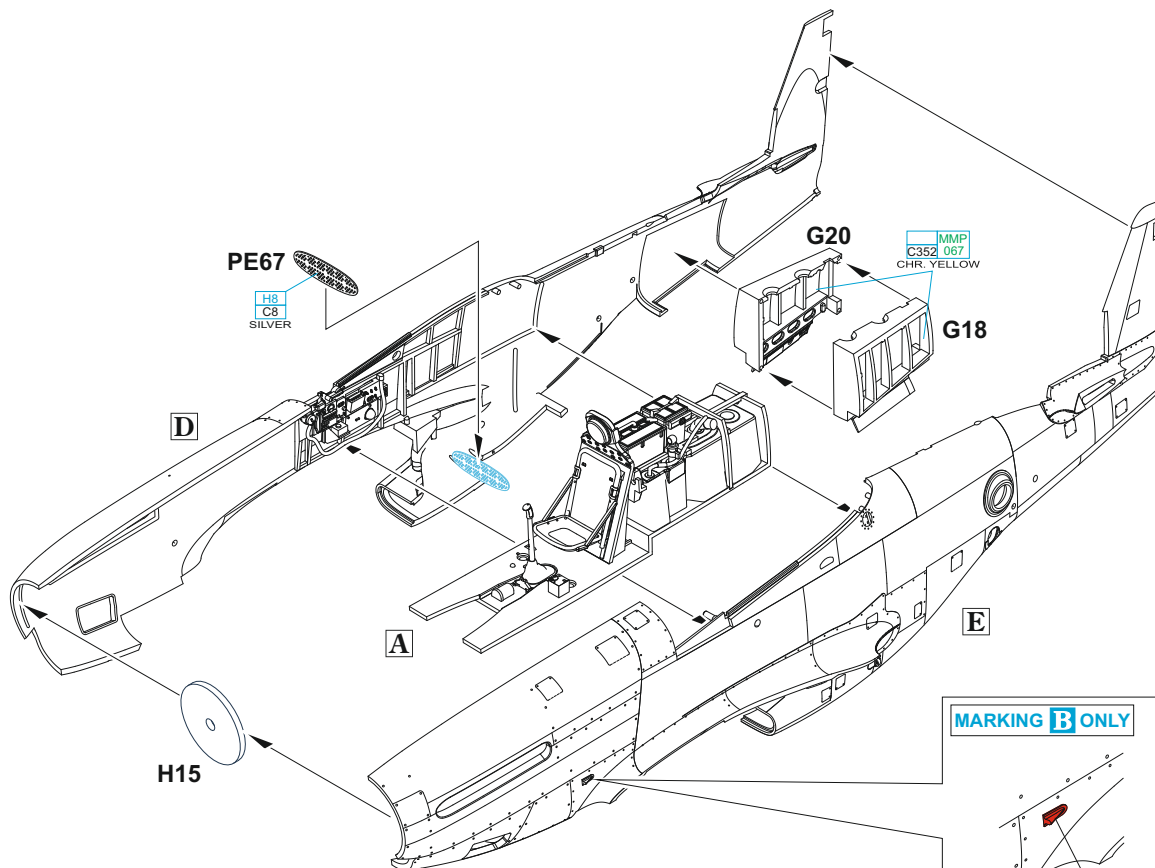
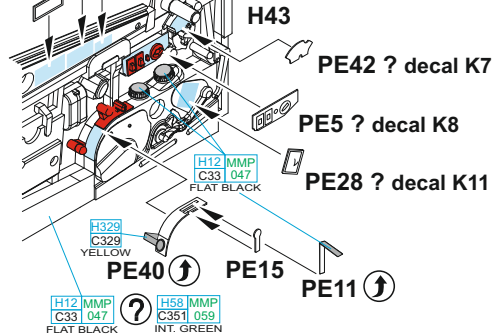

MARKING B ONLY

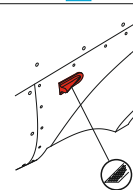

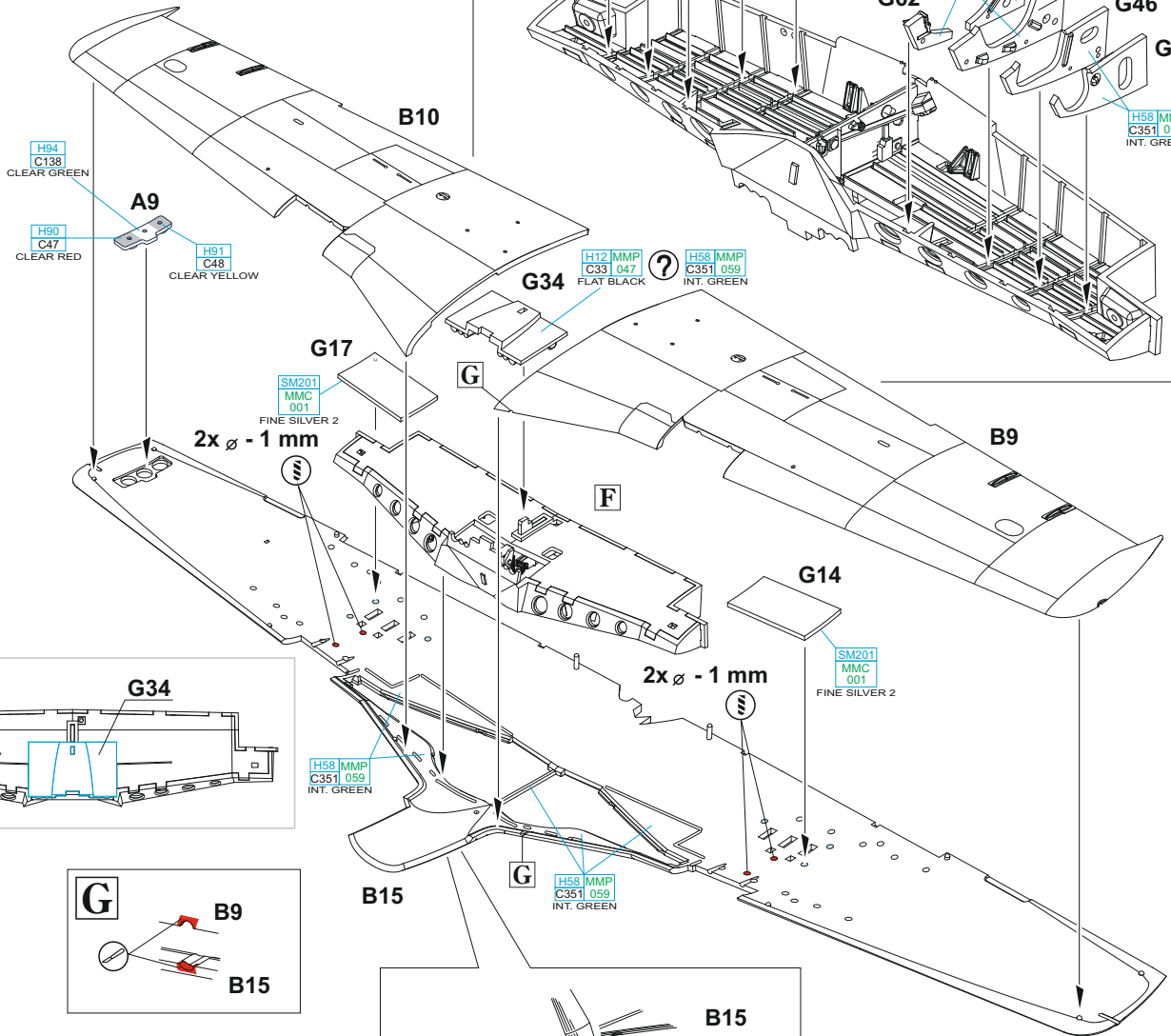
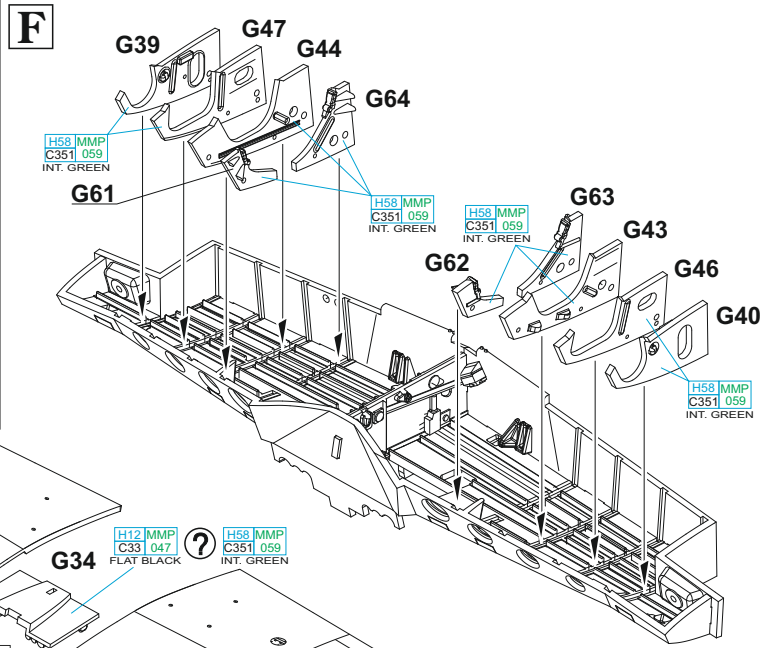
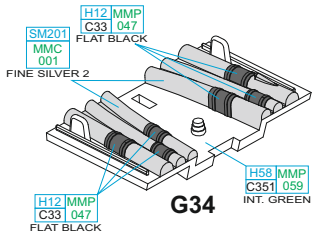
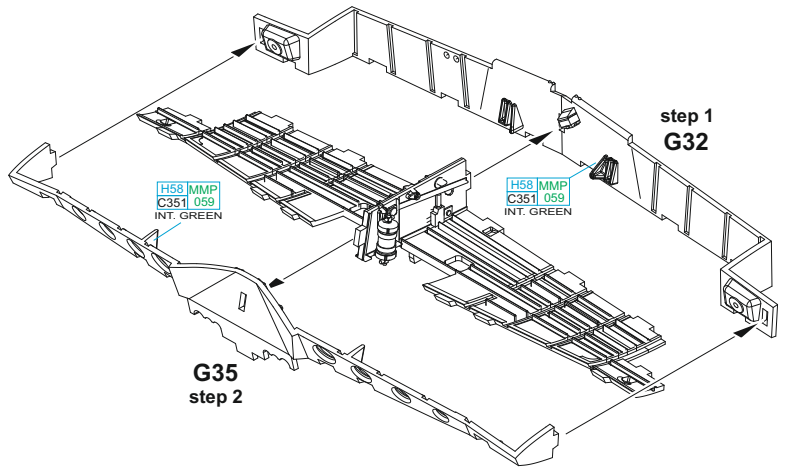
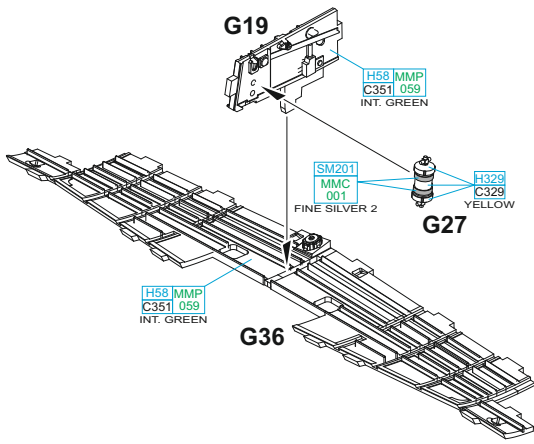

UPPER VIEW

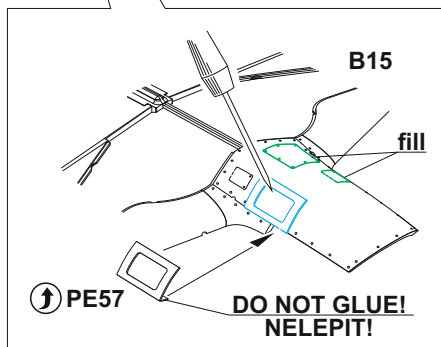
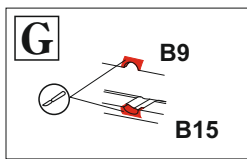
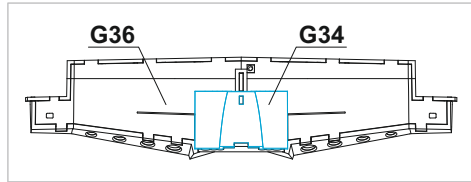

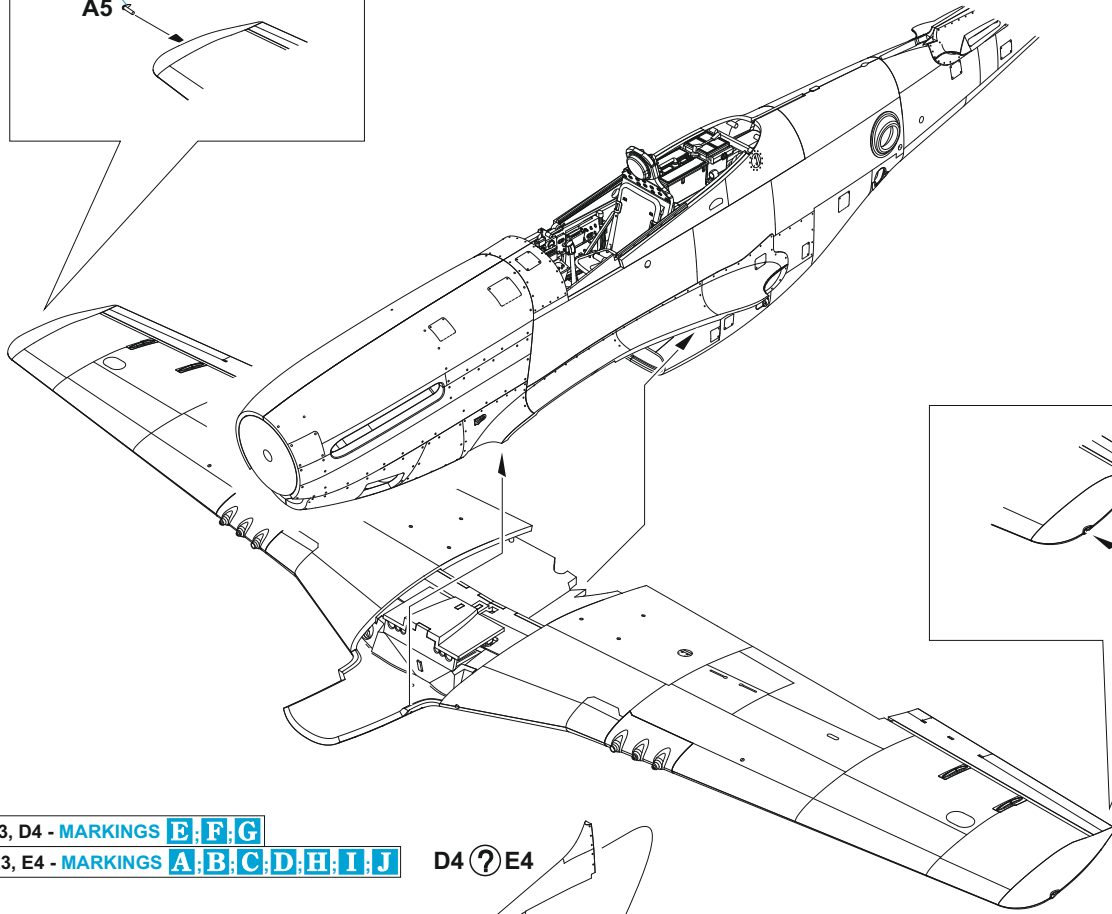
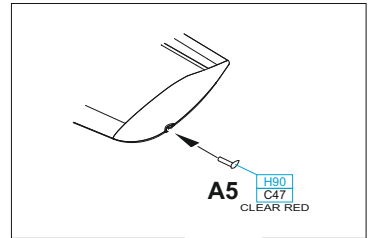
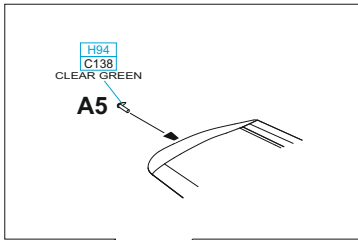
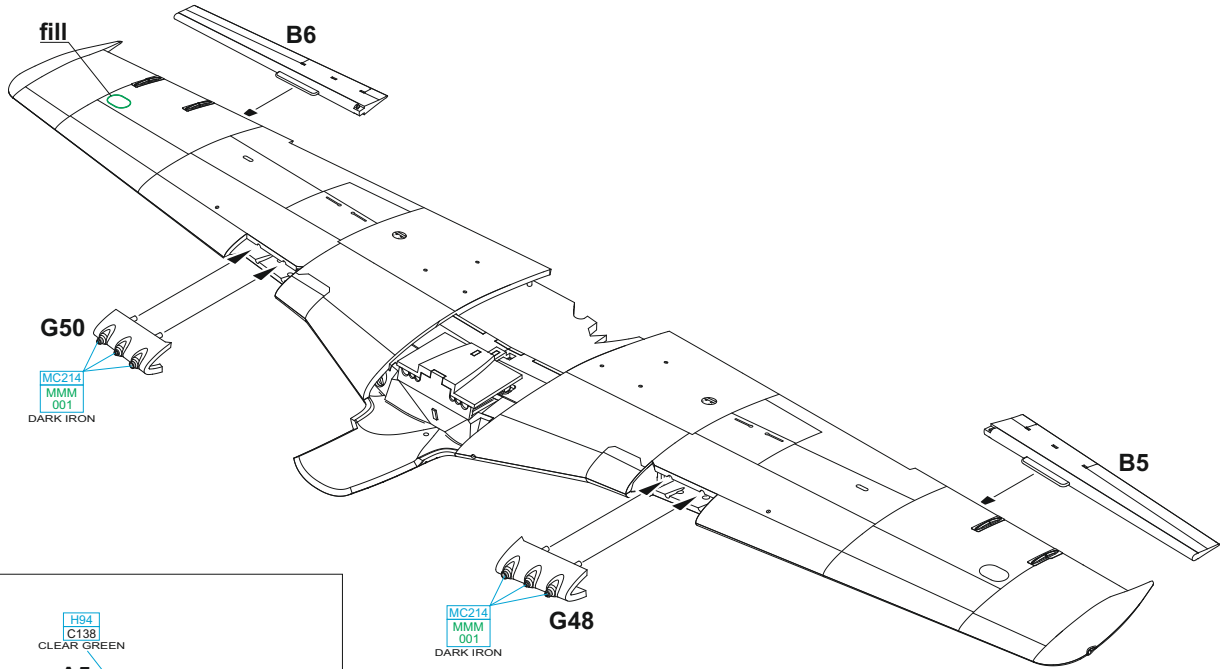

D3, D4 - MARKINGS **E, F, G**
E3, E4 - MARKINGS **A, B, C, D, H, I, J**

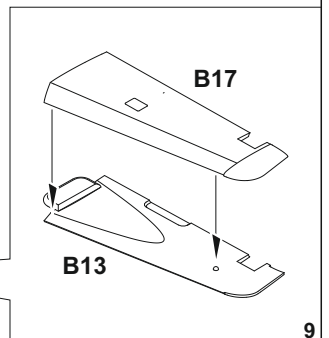
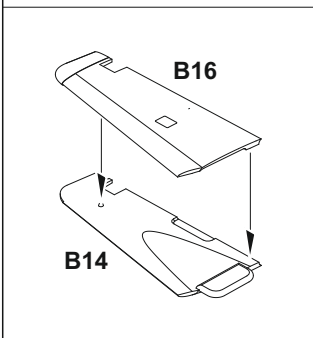
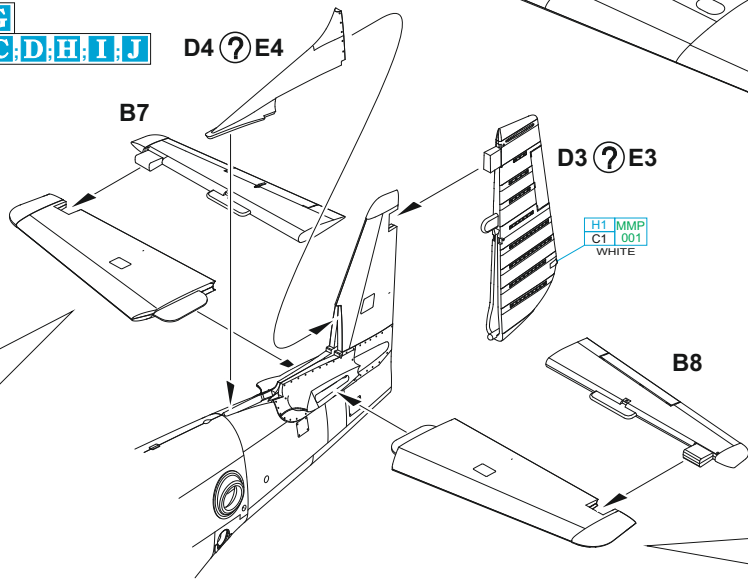

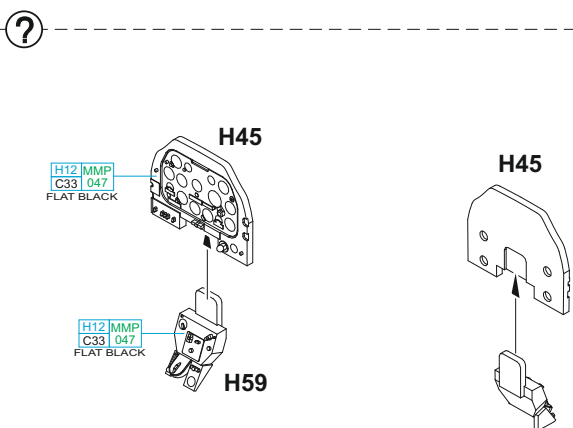
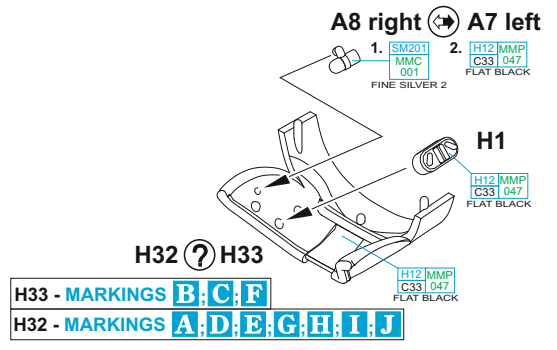
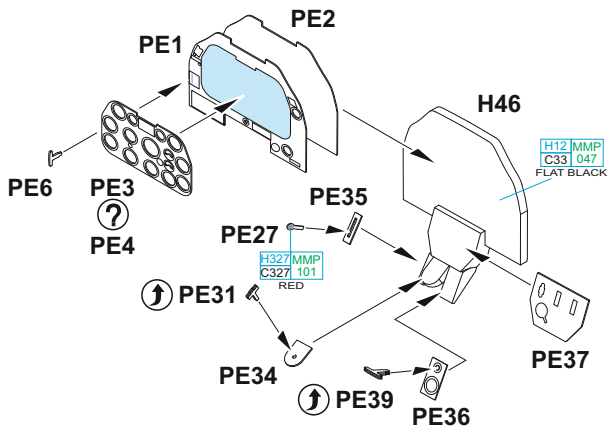

OPTIONAL: decals K1 ? K20, K2, K3, K4, K5

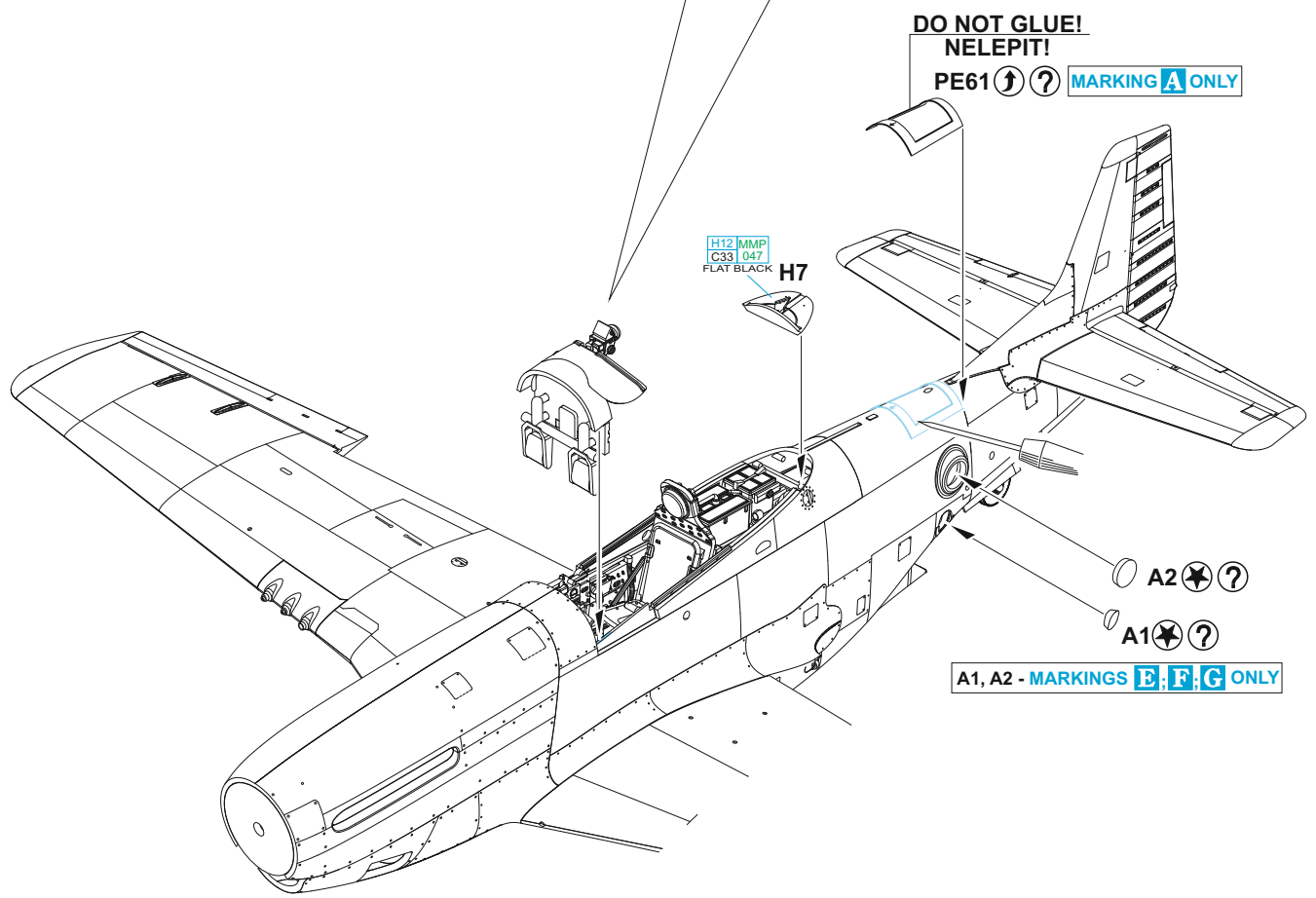
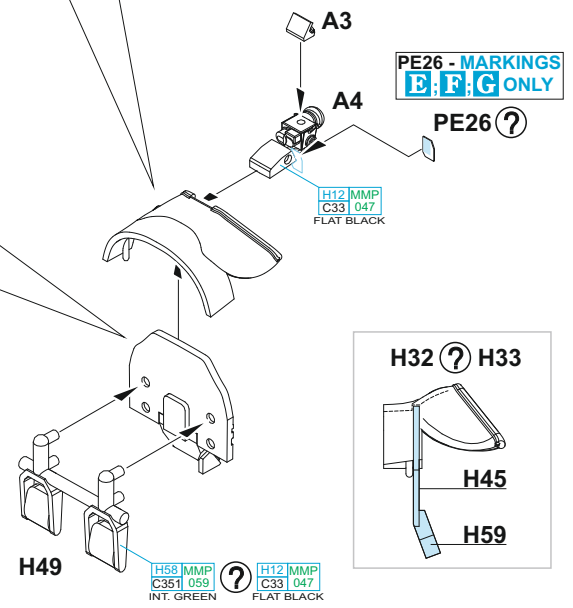

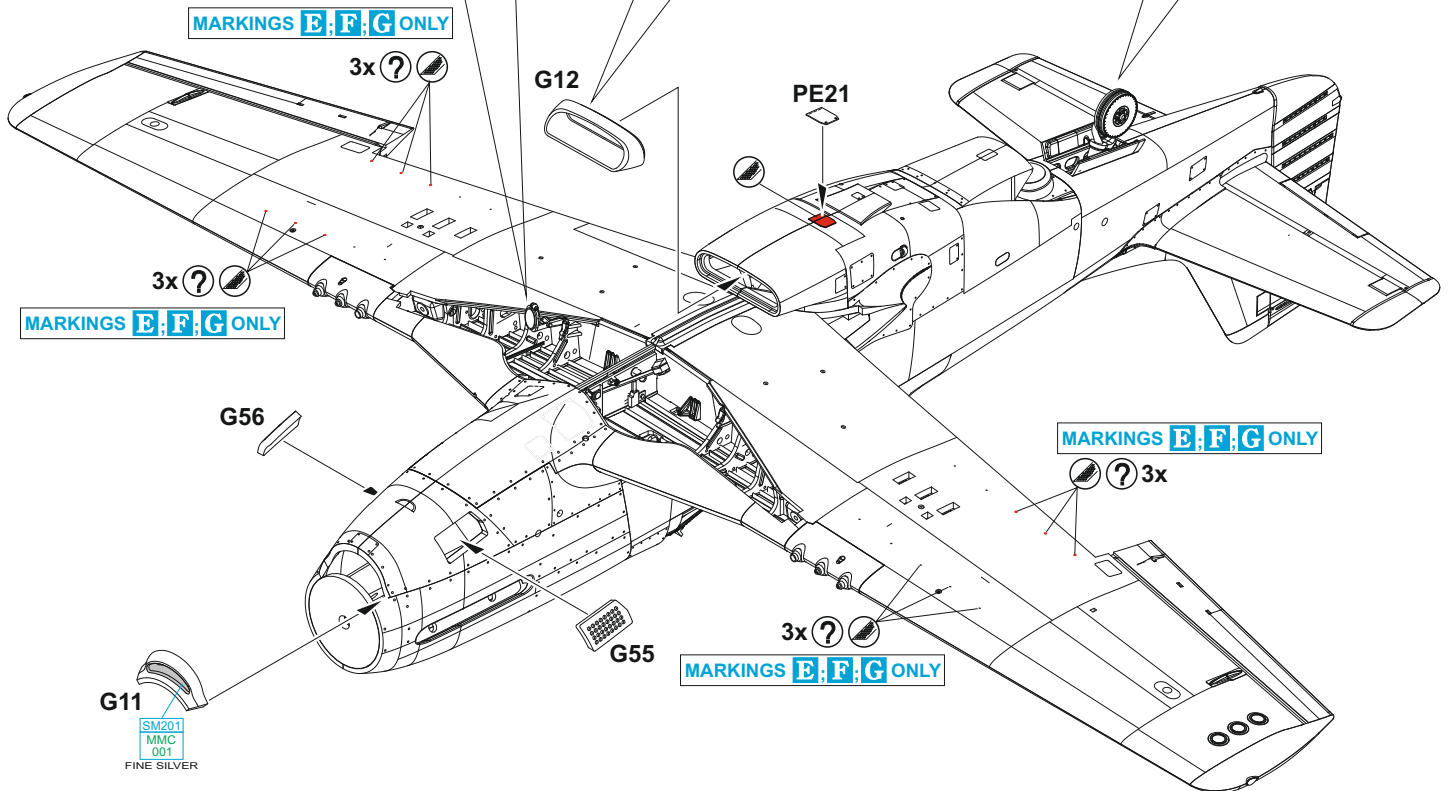
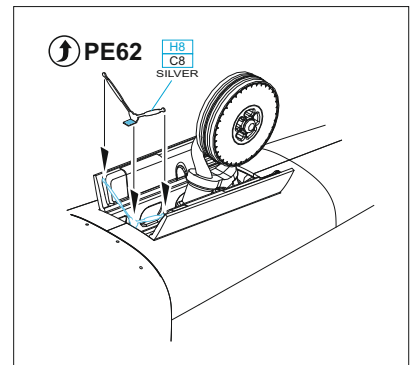
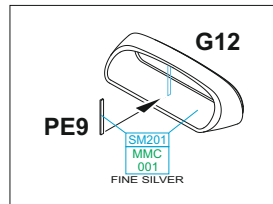
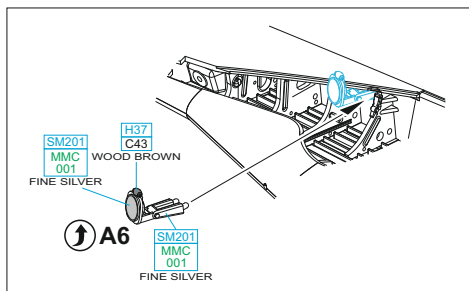
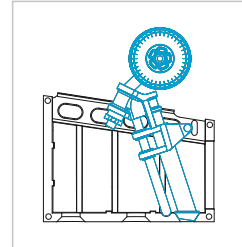
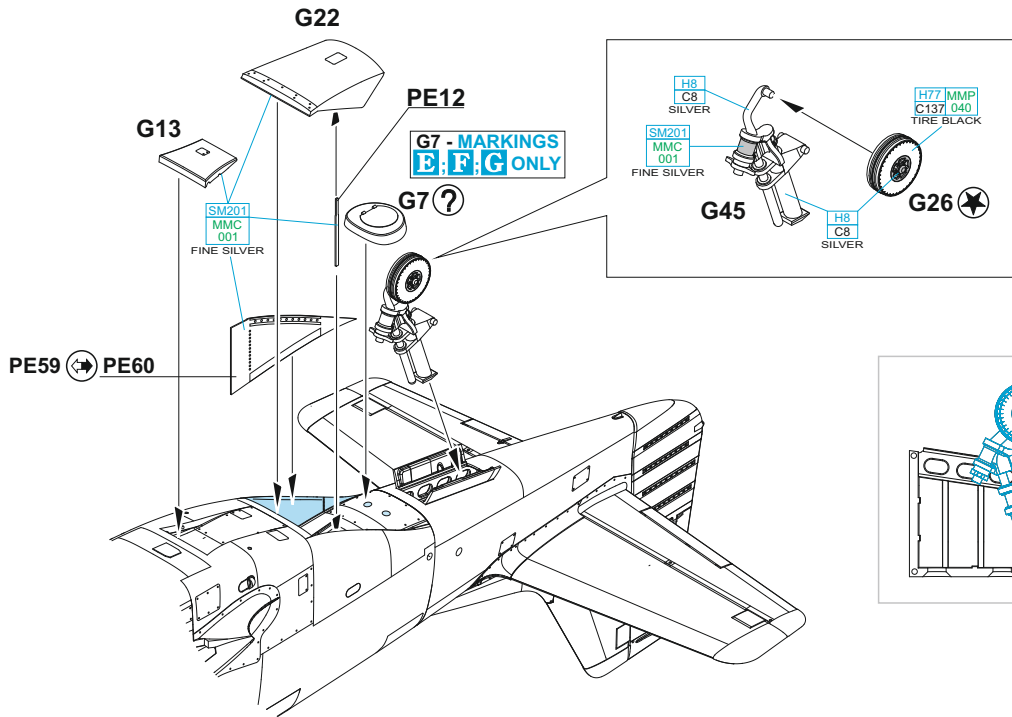

step 1 - G37, G38
step 2 - G24, G25

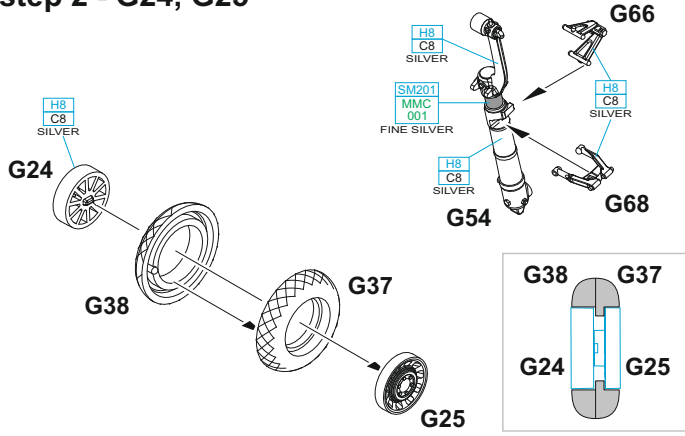

step 1 - G37, G38
step 2 - G24, G25

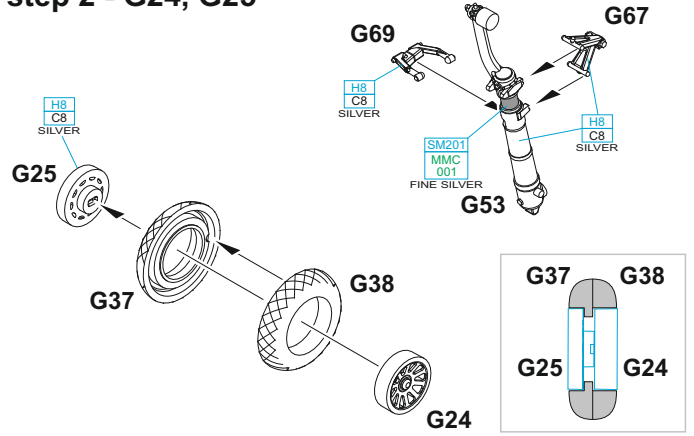

H

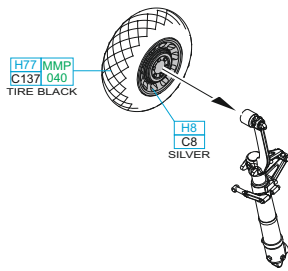

I

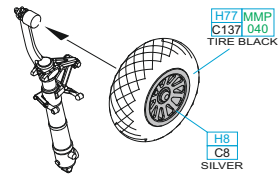

J

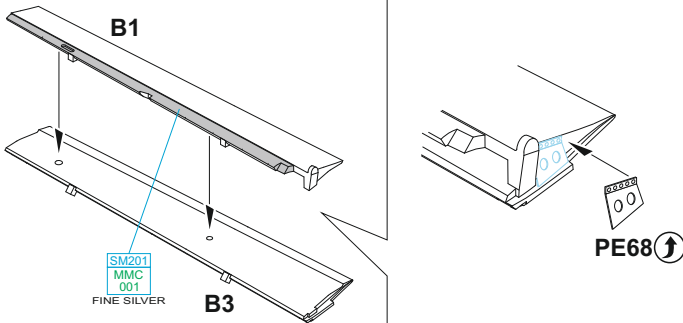

K

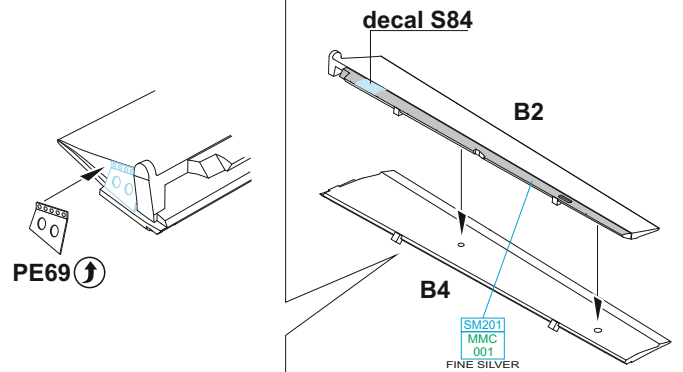

A14 ? A15

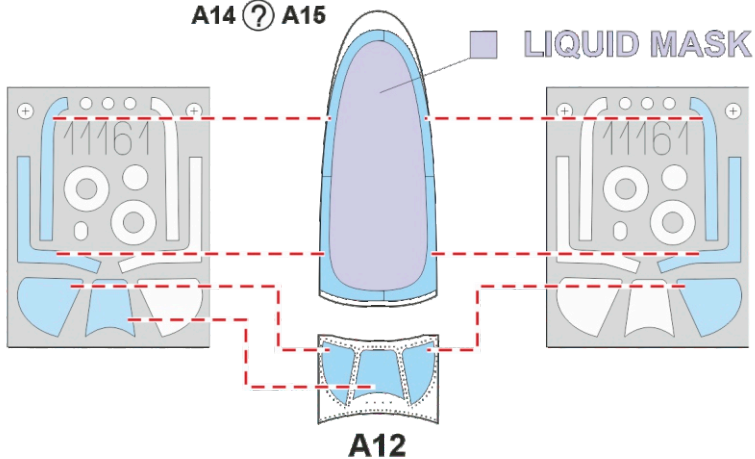

A9

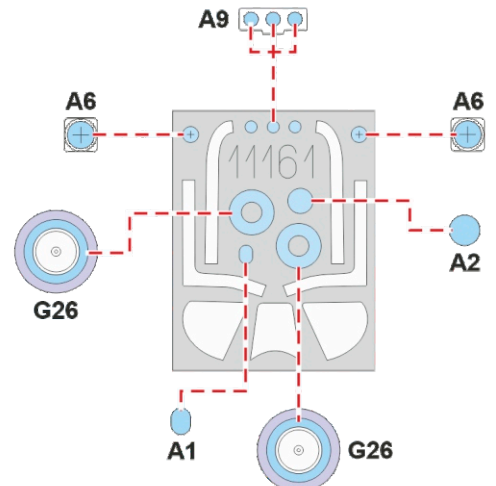

2 =

H8	C8
SILVER	

 - MARKINGS **A;C;D;E;F;H;I**

H58	MMMP
C351	059
INT. GREEN	

 - MARKINGS **B;G;J**

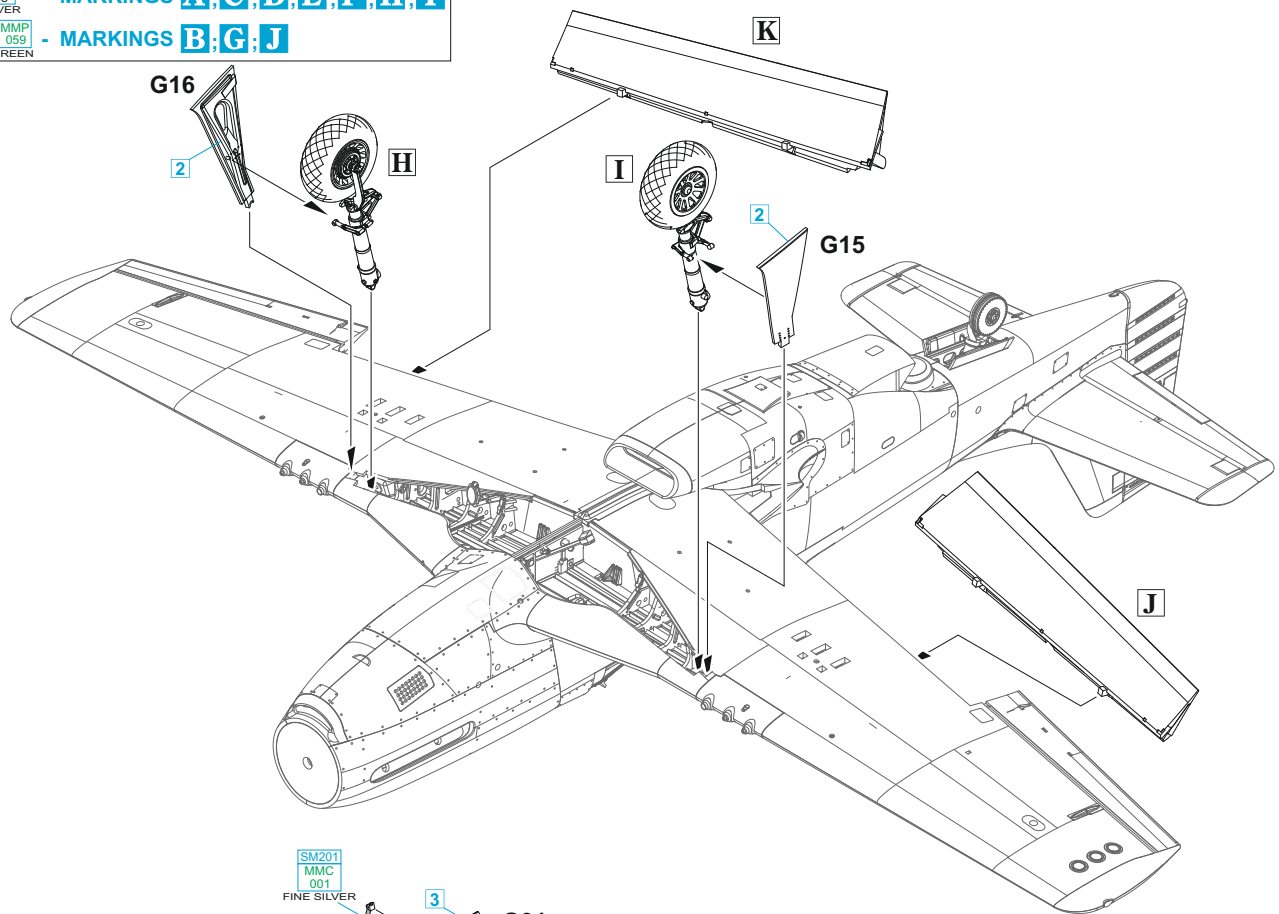

SM201	MMC	001
FINE SILVER		

3 **G65** **G31**

H8	C8
SILVER	

3 **G33**

SM201	MMC	001
FINE SILVER		

G65

H8	C8
SILVER	

H8	C8
SILVER	

 - MARKINGS **A;C;D;E;F;H**
3 =

H58	MMMP
C351	059
INT. GREEN	

 - MARKINGS **B;G;J**

MMMP	067
CHR. YELLOW	

 - MARKING **I**

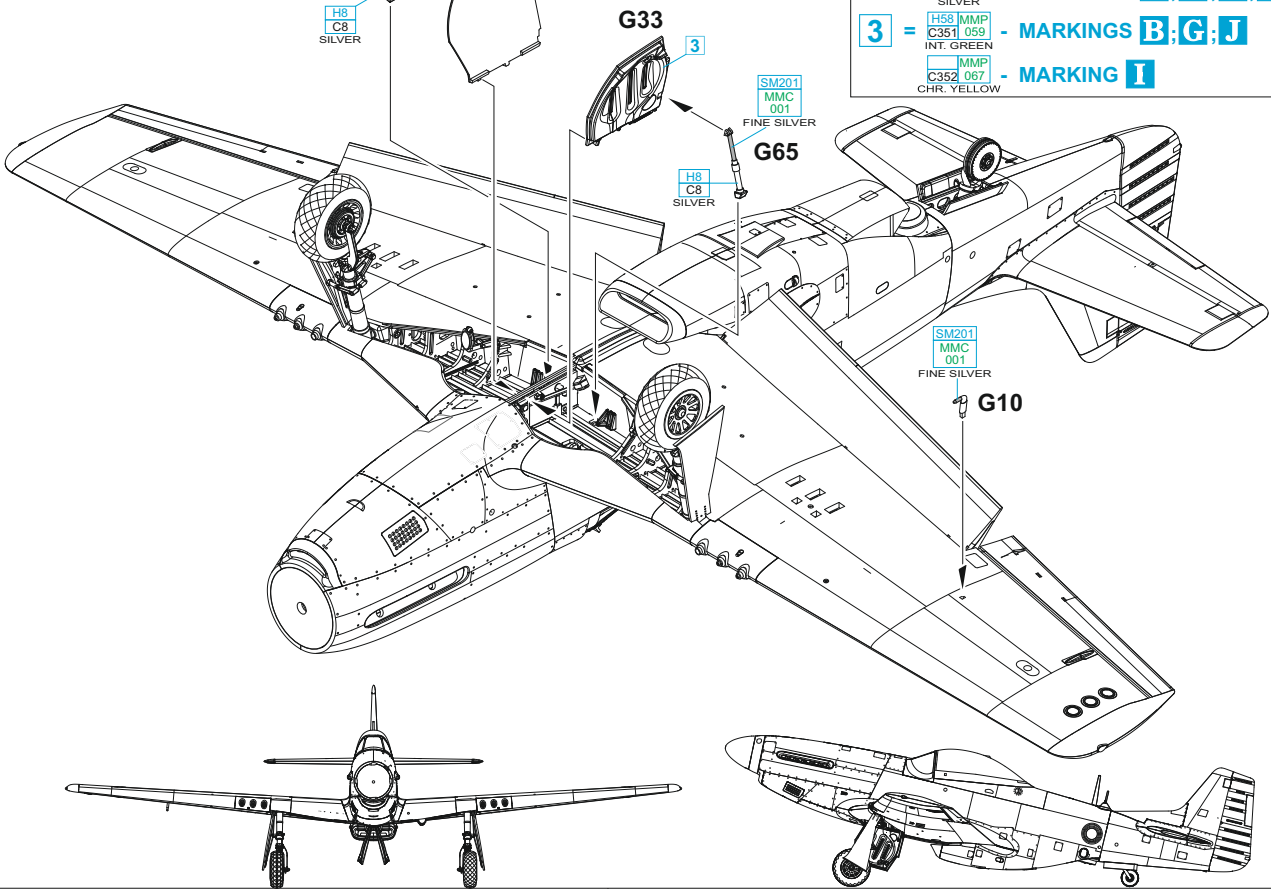

SM201	MMC	001
FINE SILVER		

G10

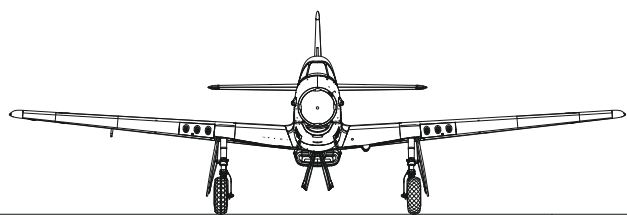

L MARKING **B**

MC214	MMM	001
DARK IRON		

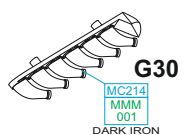
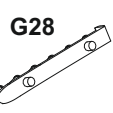

MC214	MMM	001
DARK IRON		

M MARKINGS **A;C;D;E;F;G;H;I;J**

MC214	MMM	001
DARK IRON		

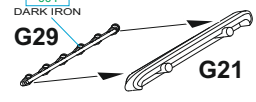

G21

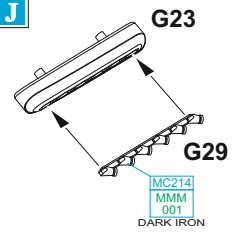

MC214	MMM	001
DARK IRON		

N H16, H27, H28, H37, H39 - MARKINGS **B, D, H, I, J**

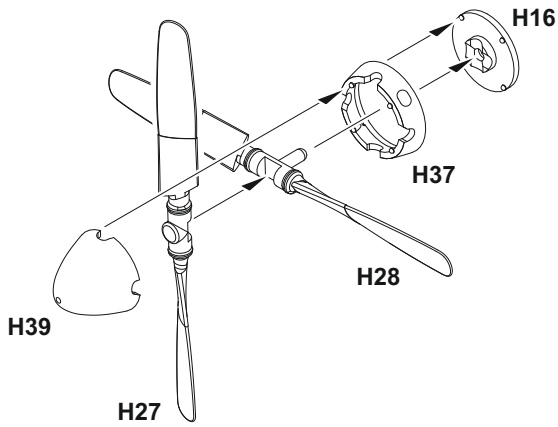

O

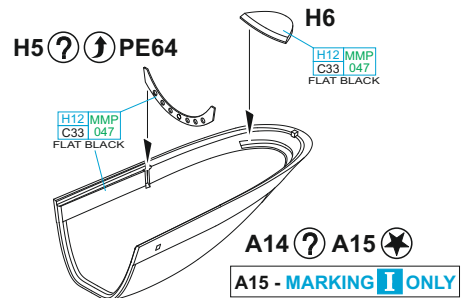

H16, H17, H18, H37, H39 - MARKINGS **A, C, E, F, G**

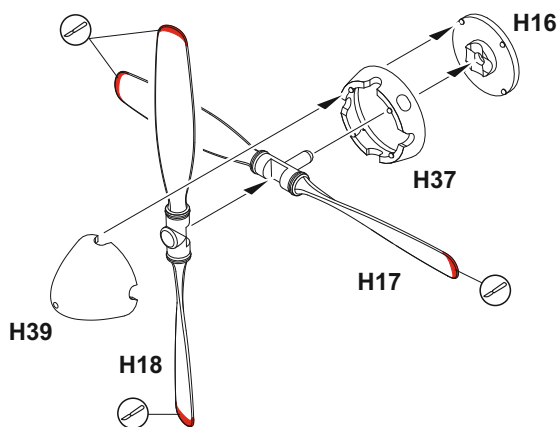

MARKING **A** ONLY

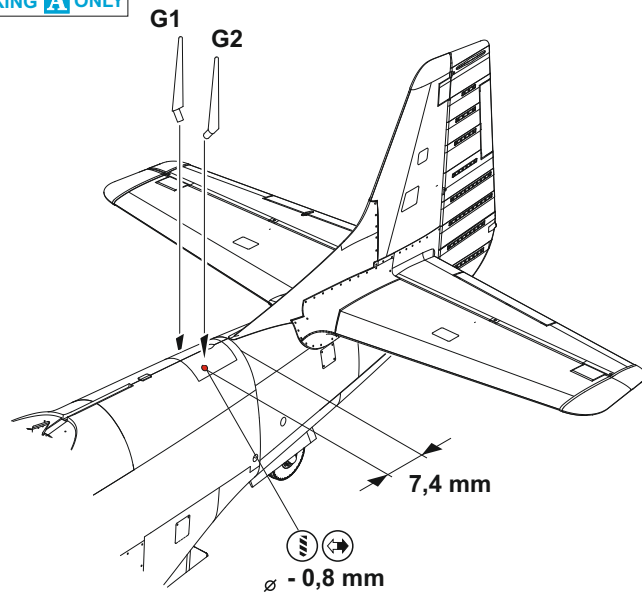

OPEN CANOPY POSITION

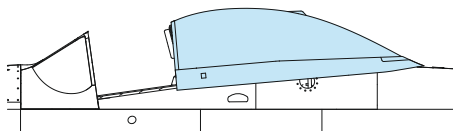

G3 - MARKINGS **B, C, D, E, F, G, H, I, J** ONLY

G8, G9 - MARKINGS **C, E, F, G** ONLY

PE66 - MARKING **B** ONLY

PE66 (with a right-pointing arrow) (with a question mark)

MARKINGS **C, E, F, G** ONLY

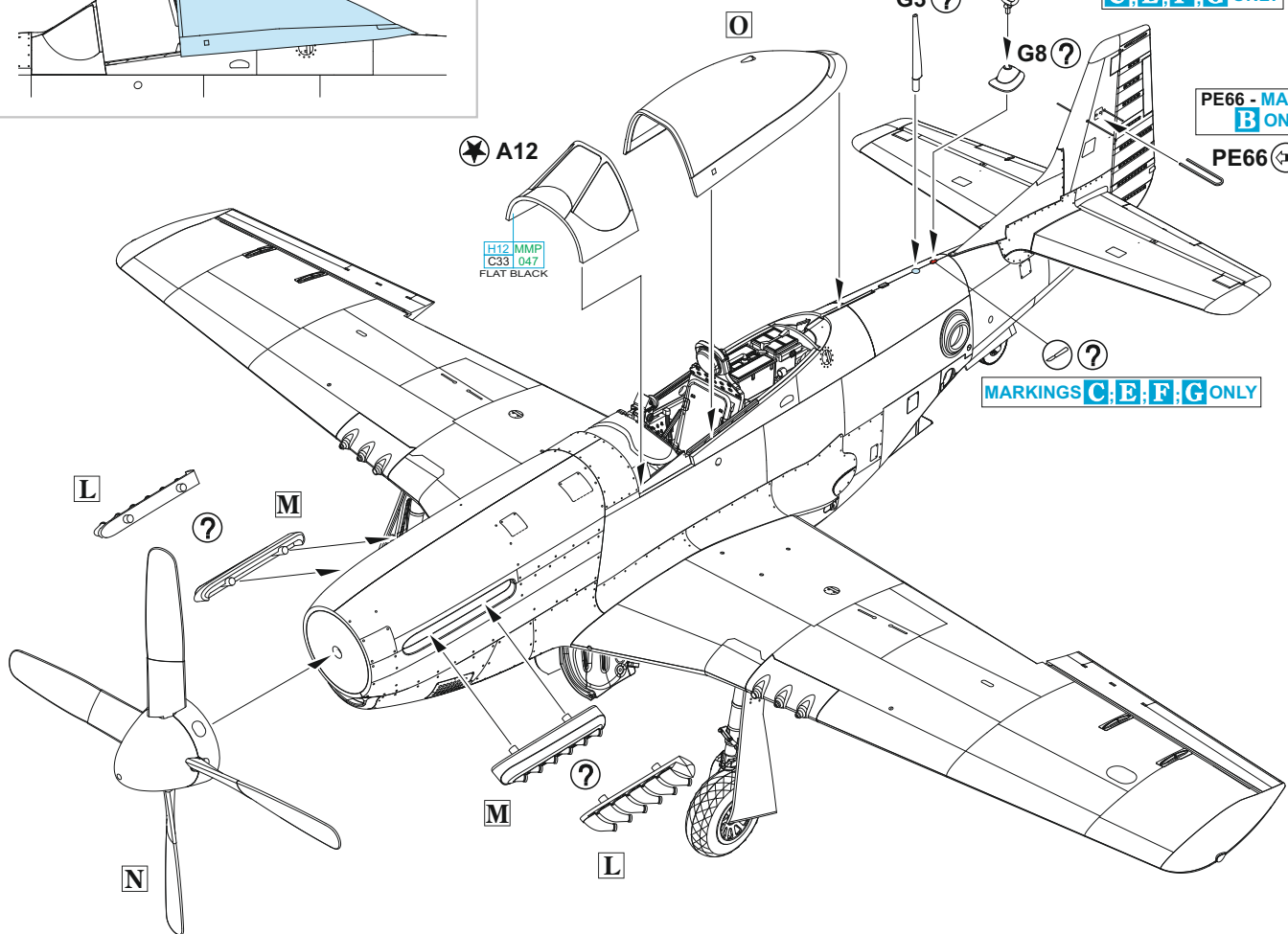

P

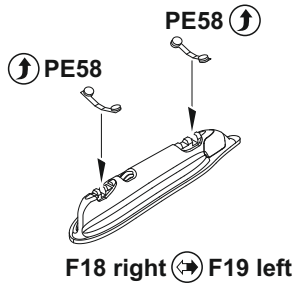

R

MARKINGS **A, E, F, G, I** ONLY

2 pcs.

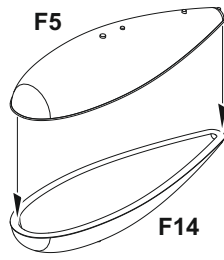

S

MARKINGS **B, C** ONLY

2 pcs.

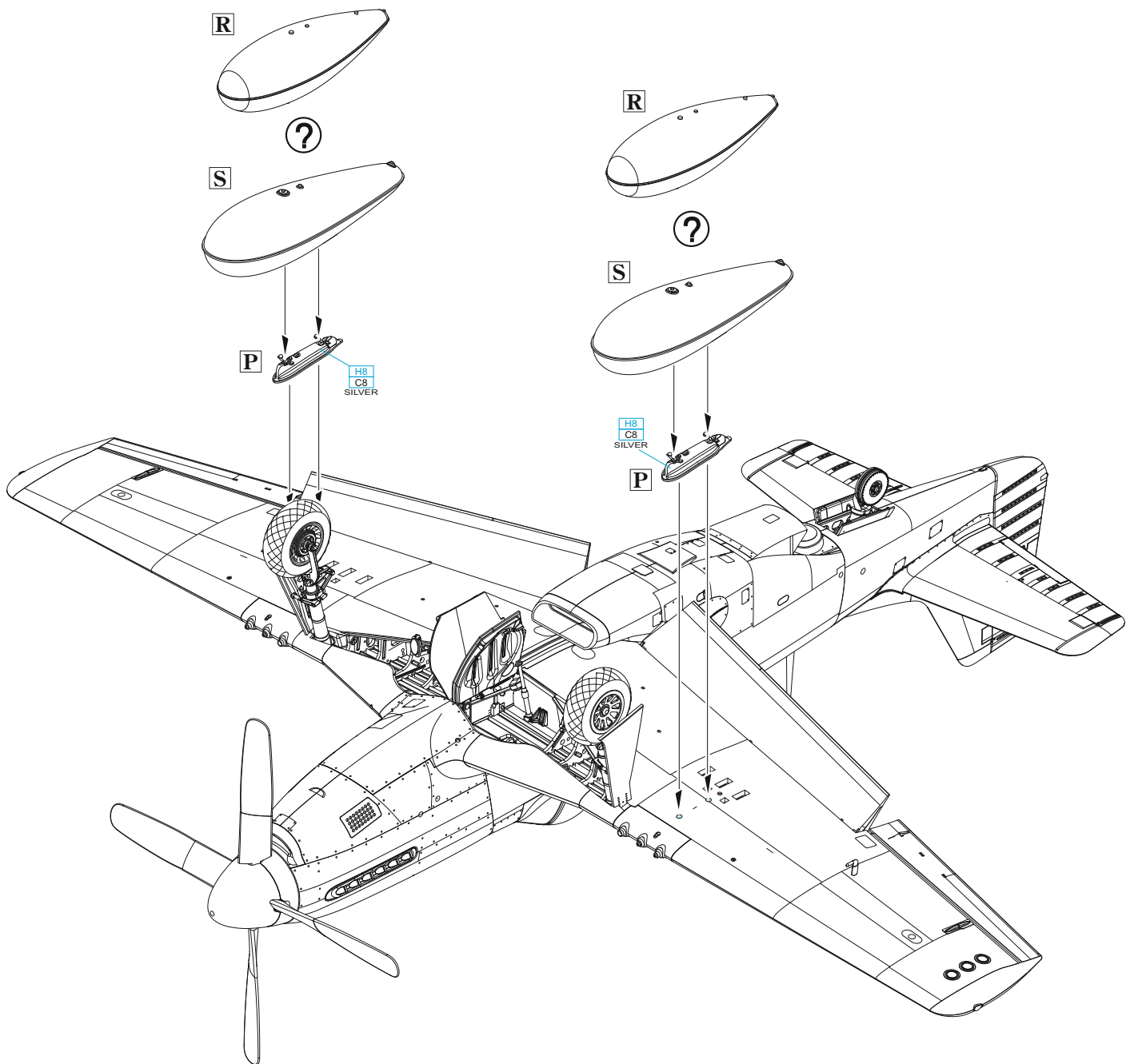
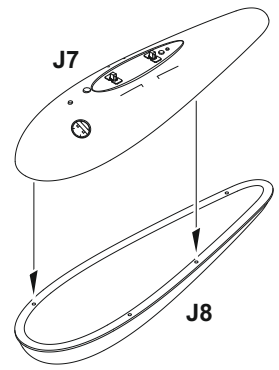

T 2 pcs.

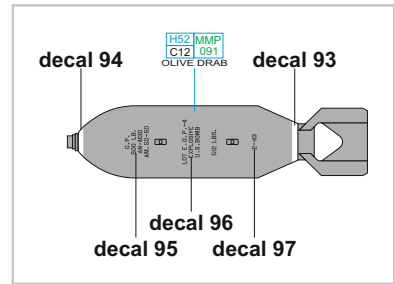
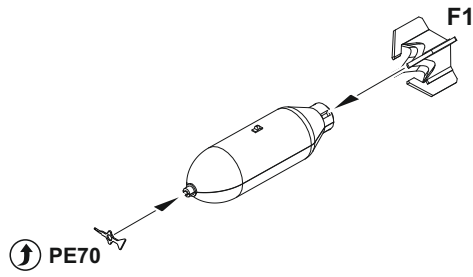
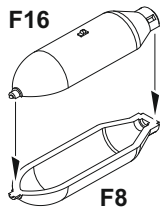

MARKINGS **D; H; J** ONLY

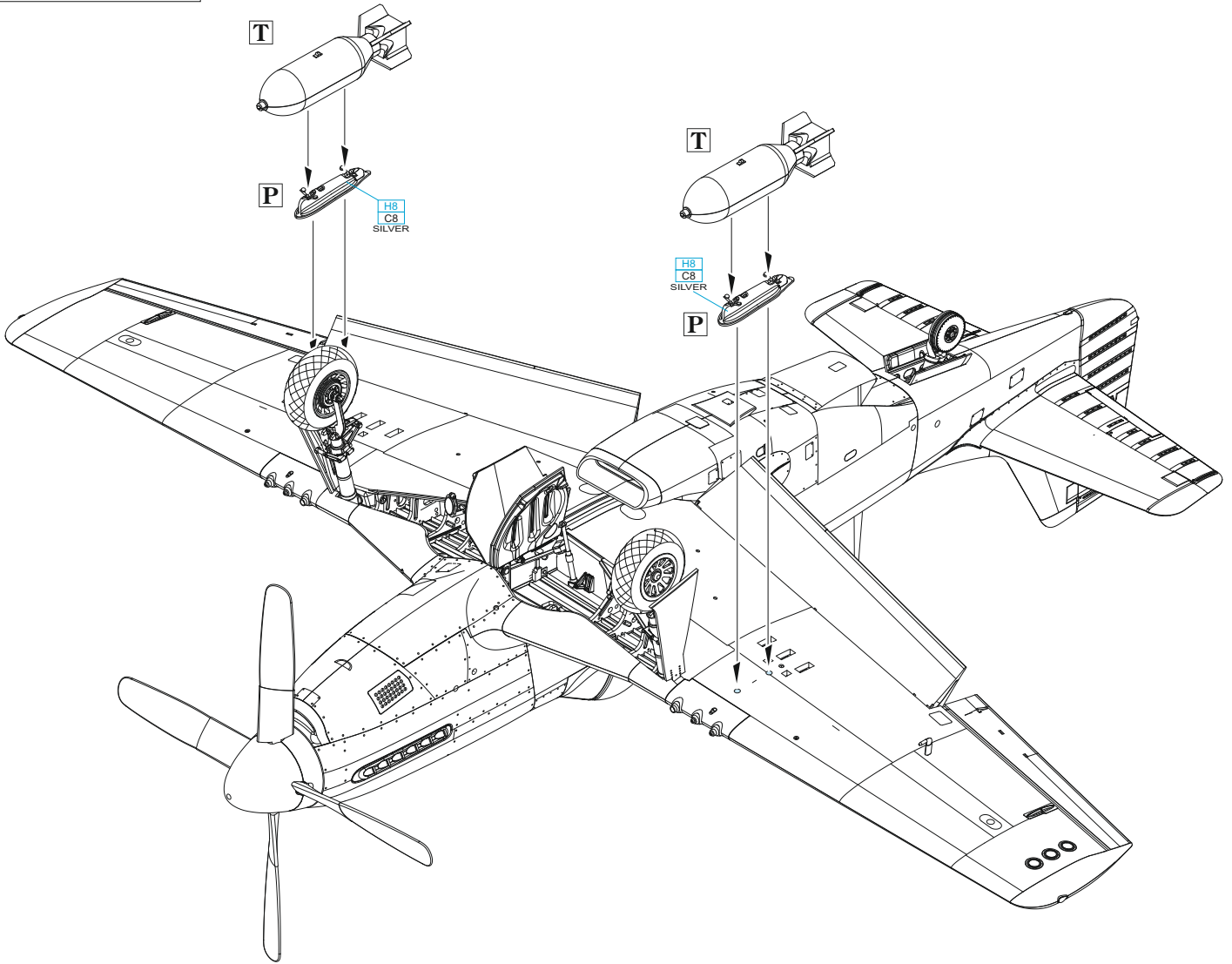

MARKINGS **A; B; C; D; H; I; J** ONLY

6 pcs.

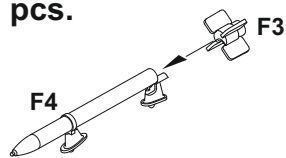

3 pcs.

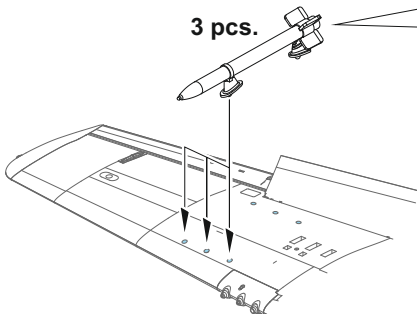

3 pcs.

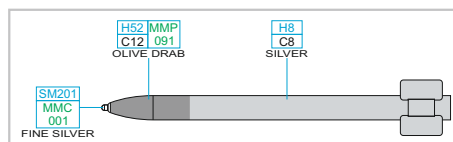
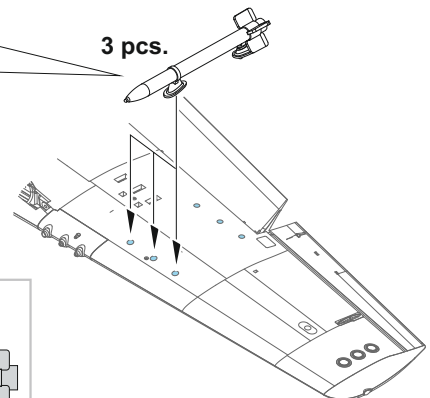

A F-51D-30, 45-11705, Lt. Robert H. Dewald, 35th FBS, 8th FBG, Seoul City AB (K-16), Korea, December 1950

8th Fighter Bomber Group (FBG) composed of 35th FBS, 36th FBS and 80th FBS was part of the Japan Occupational Forces operating their F-80 Shooting Stars in the Western Japan. Its Headquarters was located at Itazuke air base. After the outbreak of war in Korea its aircraft were among the first to take part in the combat. Due to the Shooting Star short range it was decided to equip two squadrons (35th and 36th FBS) with propeller-driven F-51 Mustang which started to provide the air support for the ground units fighting in Korea. One of the 35th FBG Mustangs was the aircraft christened Ramblin' Reck III piloted by Lt. Dewald, who at the beginning of the conflict, flying F-80 shot down a North Korean Il-10 attacking Kimpo air base. On June 5, 1951 this Mustang met its fate when flying a combat mission was shot down by anti-aircraft fire and crashed into the rice fields near Chinnampo. Its pilot, Capt. Ronald R. Cree from the 67th FBG did not survive the crash.

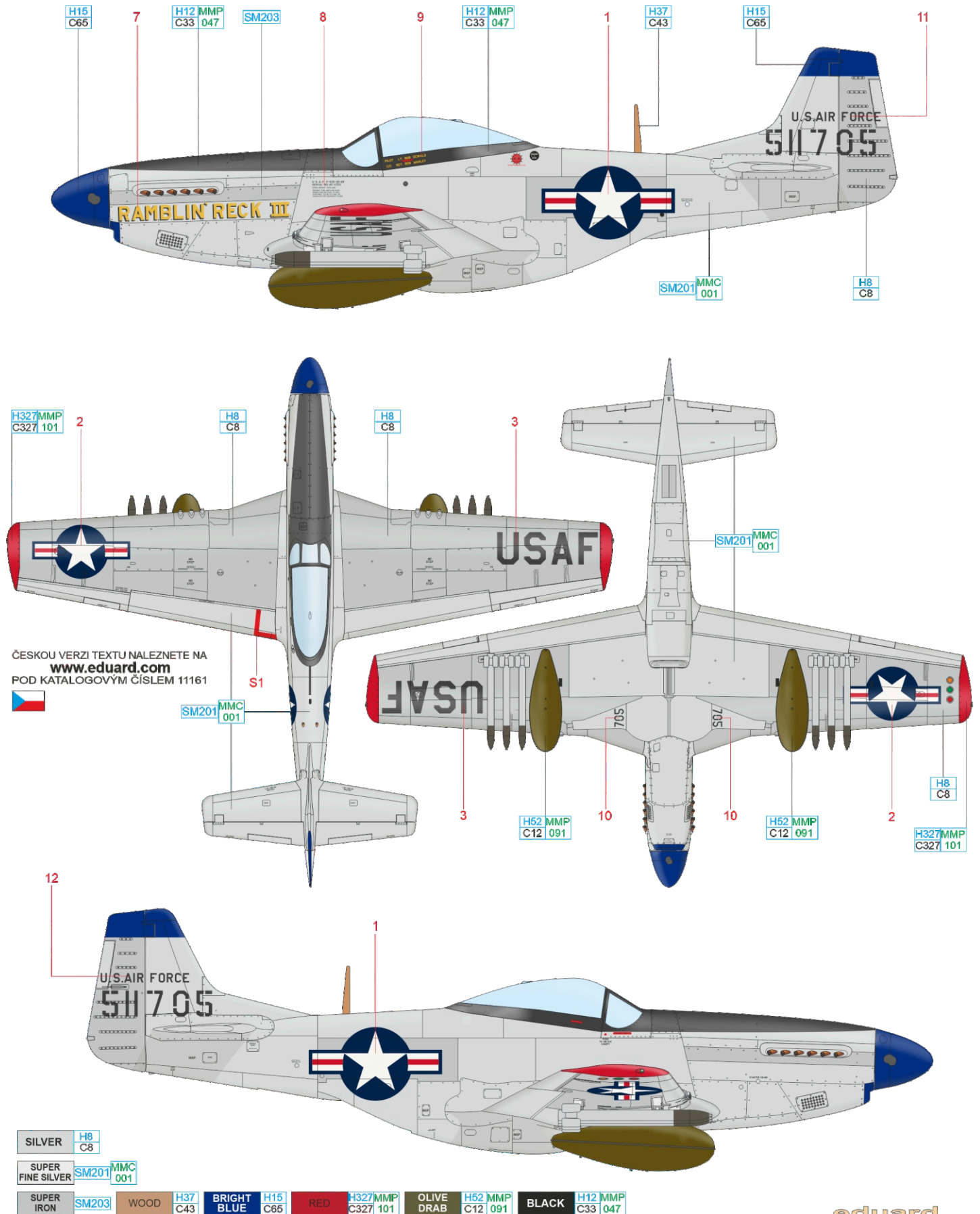

SILVER H8 C8

SUPER FINE SILVER SM201 MMC 001

SUPER IRON SM203

WOOD H37 C43

BRIGHT BLUE H15 C65

RED H327 MMP C327 101

OLIVE DRAB H52 MMP C12 091

BLACK H12 MMP C33 047

B F-51D-25, 44-73073, Lt. Daniel E. Parr, 12th FBS, 18th FBG, Pusan East AB (K-9), Korea, summer 1951

18th Fighter Bomber Group (FBG), equipped with F-80C and located at Clark air base in Philippines, after the outbreak of fighting transferred to Taegu air base in the south of Korea. In the same manner as at the 8th FBG its F-80 jets were replaced by propeller-driven F-51 Mustangs which were better suited for their assigned combat tasks i.e. close air support of the ground units. The noses of the 18th FBG Mustangs were frequently decorated with the shark mouths and this aircraft, named LIZ PIUS 3 and flown by Lt. Parr followed the custom. 18th FBG Mustangs recognition markings were the propeller spinner, wingtips and tips of the horizontal and vertical tail surfaces painted in blue color. In 1951 this Mustang was handed over to No.2 Squadron SAAF which flew within 18th FBG as well. On February 20, 1952 this airframe life came to an end when due to the battle damage a South African pilot crashed it upon landing at Chinhae air base.

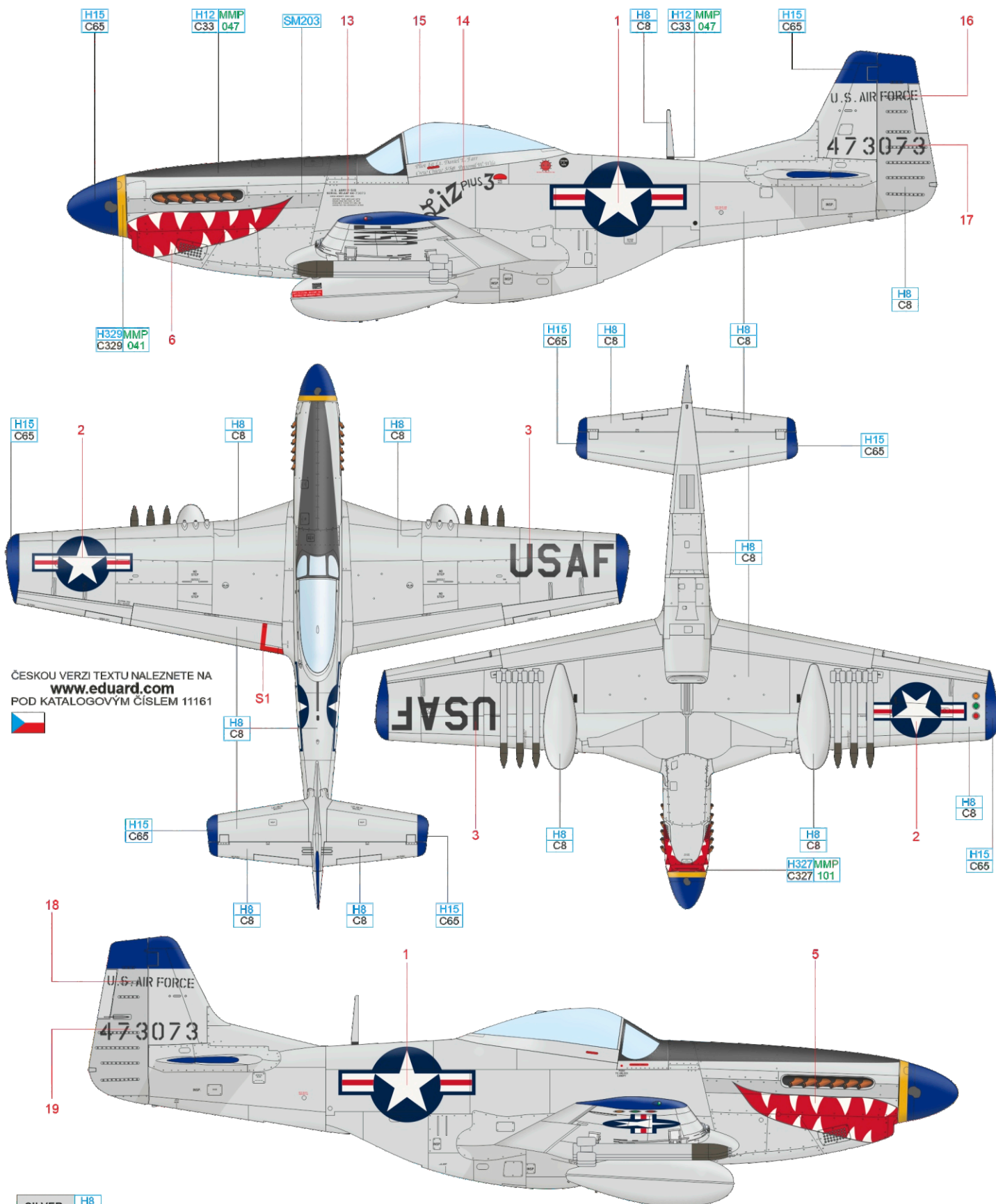

ČESKOU VERZI TEXTU NALEZNETE NA
www.eduard.com
 POD KATALOGOVÝM ČÍSLEM 11161



SILVER	H8 C8
SUPER IRON	SM203
YELLOW	H329 MMP C329 041
RED	H327 MMP C327 101
BRIGHT BLUE	H15 C65
BLACK	H12 MMP C33 047

In the summer of 1951, Major Davis, WWII combat veteran having flown P-39 and P-40 with 347th FG in 145 missions, commanded the 39th FIS which was incorporated into 18th FBG. On August 14, 1951 he flew his 35th mission in Korea. It was a raid on the North Korea capital, Pyongyang, where he together with another eleven Mustangs executed a devastating napalm attack on the city warehouses. During the attack his Mustang was hit and on the return flight the engine failed resulting in the aircraft crash killing the pilot. Major Davis flew the Mustang christened SEXY SALLY II sporting a pin-up girl artwork.

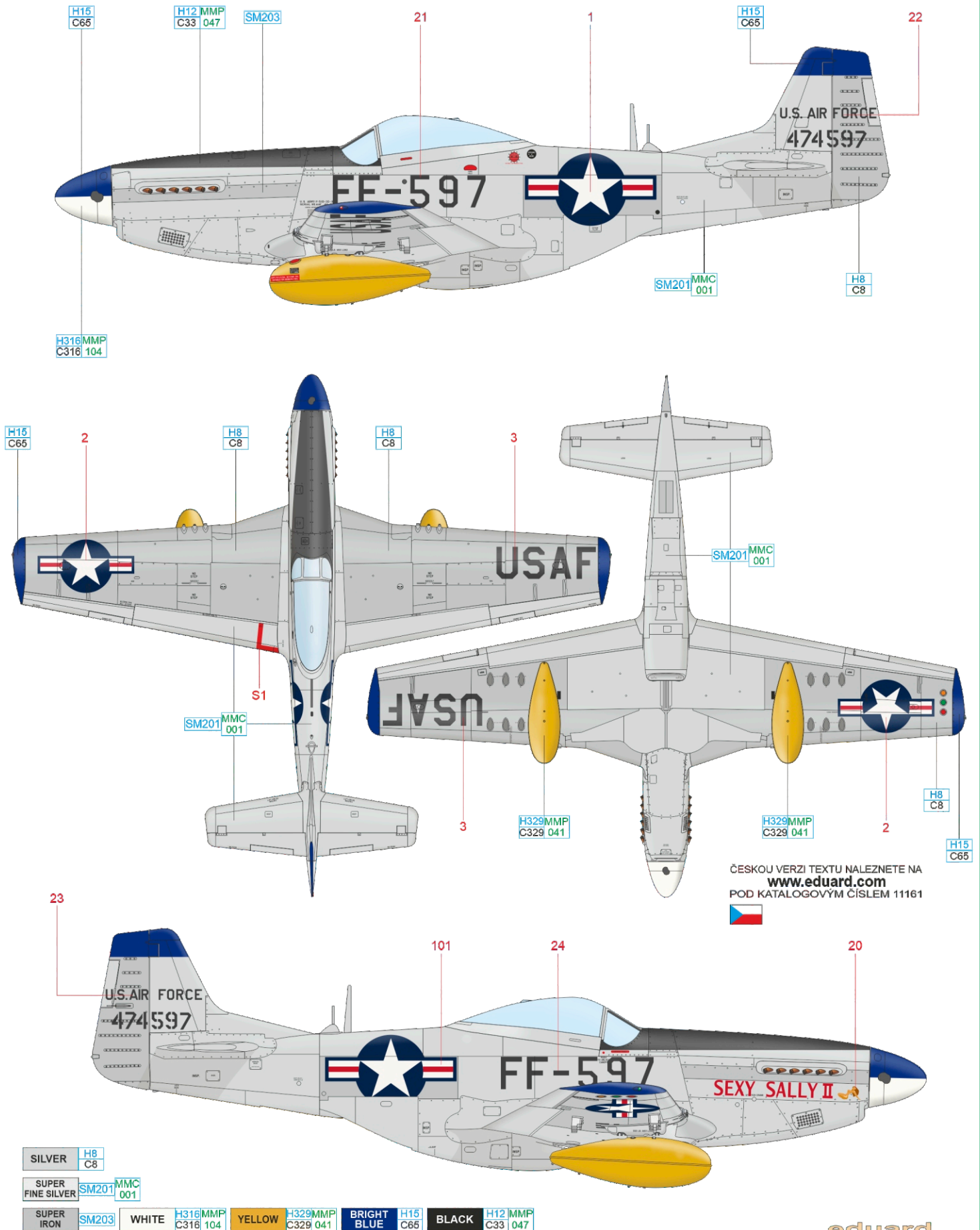

ČESKOU VERZI TEXTU NALEZNETE NA
www.eduard.com
 POD KATALOGOVÝM ČÍSLEM 11161



SILVER	H8 C8	WHITE	H316 MMP C316 104	YELLOW	H329 MMP C329 041	BRIGHT BLUE	H15 C65	BLACK	H12 MMP C33 047
SUPER FINE SILVER	SM201 MMC 001								
SUPER IRON	SM203								

D F-51D-30, 44-74651, Col. William H. Clark, CO of 18th FBG, Hoengsong AB (K-46), Korea, July 1952

In March 1952 the command of the 18th FBG was assumed by Col. Ernest G. Ford replacing Col. William H. Clark. Ford led the unit until January 1, 1953. His Mustang is attractive due to its "decoration", it carries the 18th FBG insignia on the fuselage starboard while the port side sports the insignia of all group's units which at that time were 12th FBS, 67th FBS and No. 2 Squadron SAAF. At the same time, behind the US star this aircraft carried three oblique stripes representing the individual squadrons: red, yellow and orange-white-blue. On July 28, 1953, a day after the armistice, which lasts until today, this aircraft was handed over to the Korean Republic Air Force.

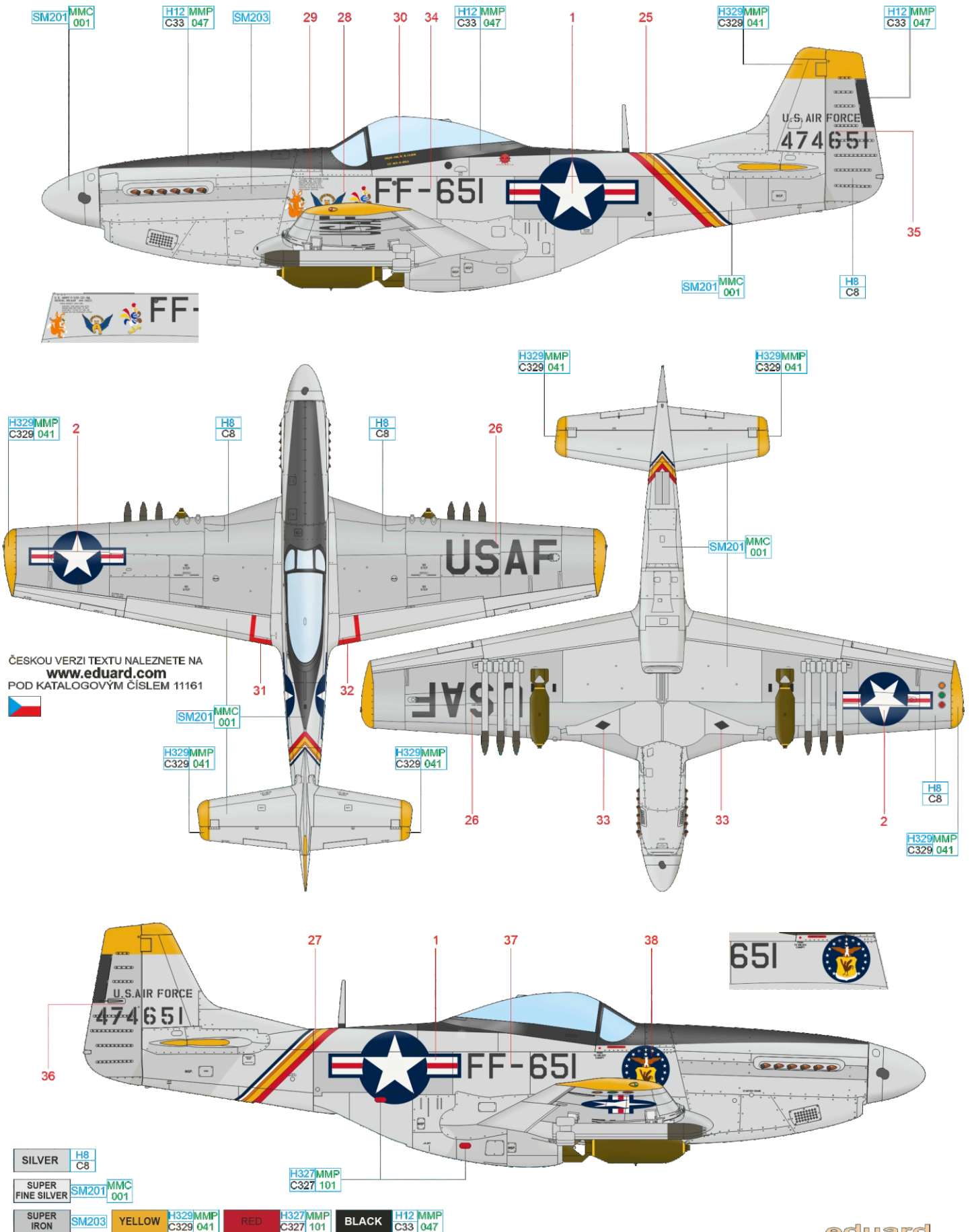

E RF-51D-25, 44-84840, Lt. Frank M. Ward, 45th TRS, 67th TRG, Taegu AB (K-2), Korea, July 1951

The only unit flying Mustangs equipped with a camera, currently designated as RF-51, over the Korean peninsula was 45th Tactical Reconnaissance Squadron. One of its aircraft was the Sweet Lorraine proudly carrying the emblem of the State of California on its nose. The further tactical reconnaissance for the benefit of UN units was cut short in the case of this Mustang by anti-aircraft fire which forced the pilot, Lt. Ward to bale out. Sweet Lorraine plunged into the ground near Yongson-Li and exploded.

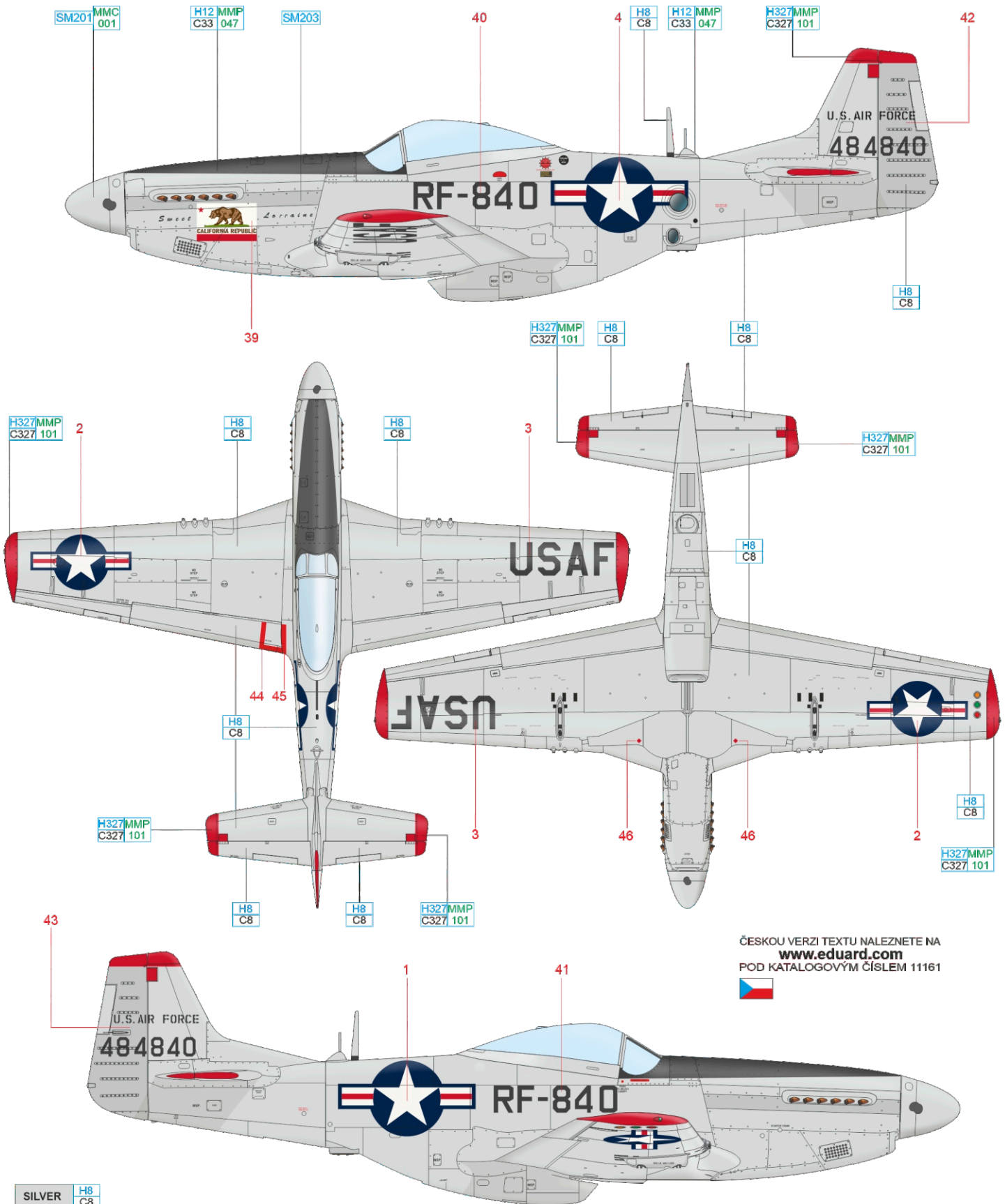

ČESKOU VERZI TEXTU NALEZNETE NA
www.eduard.com
 POD KATALOGOVÝM ČÍSLEM 11161



SILVER	H8			
	C8			
SUPER FINE SILVER	SM201	MMC		
		001		
SUPER IRON	SM203	RED	H327MMP	BLACK
			C327 101	H12 MMP
				C33 047

F RF-51K-10, 44-12237, Lt. Watts/Lt. Taylor, 45th TRS, 67th TRG, Kimpo AB (K-14), Korea, 1952

The 45th TRS was activated on September 3, 1950 at Itazuke air base in Japan. Its equipment consisted of F-51 and RF-51 versions of Mustang. Together with 15th TRS (RF-80) and 12th TRS (RB-26) it was under command of 57th TRG led by no one else than Col. Karl I. Polifka, the leading USAF expert on aerial reconnaissance. The reconnaissance Mustangs escorted by the standard Mustang fighters initially flew out of Komaki air base in Japan. Once the situation and airport equipment permitted in March 1951 they transferred to the Korean peninsula. First to Taegu air base and in August of the same year to Kimpo air base from where it operated until the end of hostilities. One of the 45th TRS aircraft nicknamed Polka Dot thanks to its colorful markings on the propeller spinner, wingtips and tail surfaces was this Mustang named Punkin. Under its windshield it carried the symbols of ten reconnaissance missions. Its career was ended on the last day of 1952 by the anti-aircraft fire near Singo-san. It also cut short the life of its pilot...

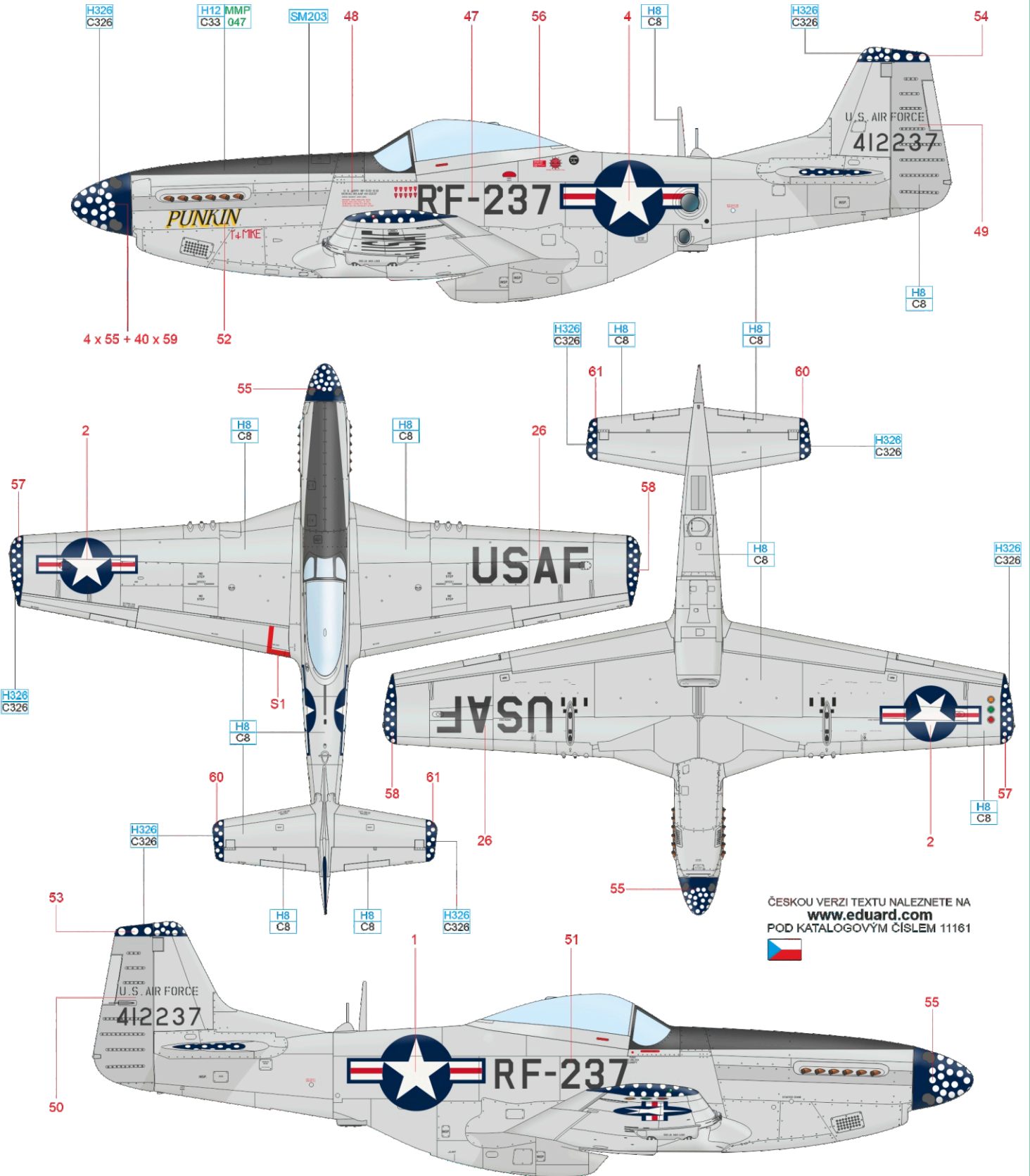

ČESKOU VERZI TEXTU NALEZNETE NA
www.eduard.com
 POD KATALOGOVÝM ČÍSLEM 11161



SILVER	H8 C8
SUPER IRON	SM203
BLUE	H326 C326
BLACK	H12 MMP C33 047

G RF-51D-25, 44-84837, Lt. Grover J. Isbell, 45th TRS, 67th TRG, Kimpo AB (K-14), Korea, 1952

This Mustang, christened Little Lynn, proudly carries more than hundred little camera symbols representing the completed missions during the Korean War. It was flown by Dallas, Texas native, and a WWII veteran Lt. Grover Jim Isbell. The Korean War was not the last conflict he participated in. He also fought in Vietnam and retired as Major General. His Mustang survived the Korean War and after the end of hostilities continued to fly with the Arkansas Air National Guard in 154th TRS.

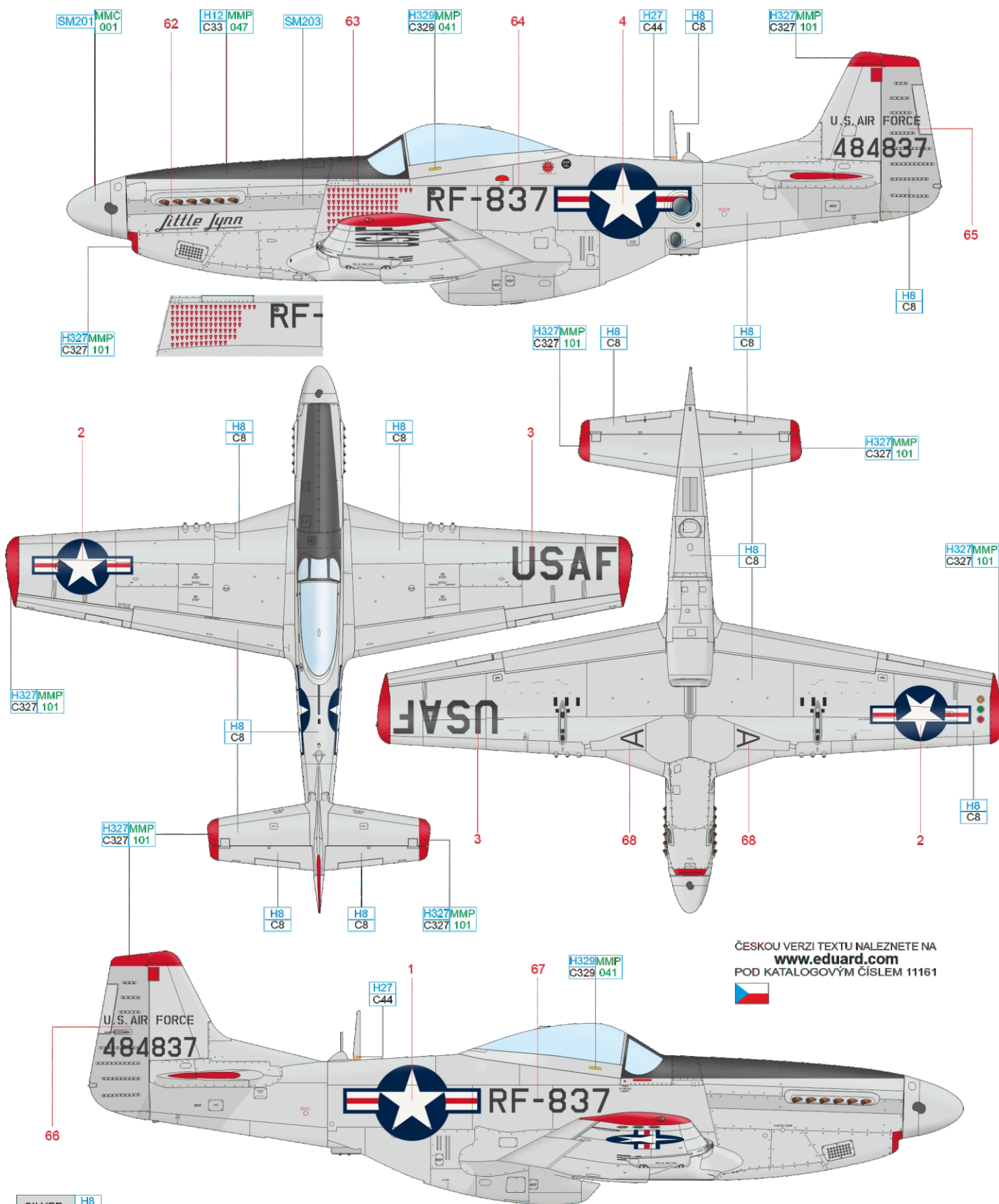

ČESKOU VERZI TEXTU NALEZNETE NA
www.eduard.com
POD KATALOGOVÝM ČÍSLEM 11161



SILVER	H8	C8							
SUPER FINE SILVER	SM201	MMC 001							
SUPER IRON	SM203	TAN	H27 C44	YELLOW	H329 MMP C329 041	RED	H327 MMP C327 101	BLACK	H12 MMP C33 047

H F-51D-30, 44-74629, Col. Dean E. Hess, ROKAF, Seoul City AB (K-16), Korea, October 1950

In the beginning of the Korean conflict the South Korean air forces were equipped with communication and training aircraft only. Therefore ten Mustangs were released for the US stocks and training of selected Korean pilots took place in Japan under the command of Maj. Hess. Under his leadership the unit designated Bout One transferred back to the Korean peninsula from where the sorties were flown first by the American instructors and then, after their piloting skills improved, by the Korean pilots. Col. Hess together with LTC Russell L. Blaisdell and S/Sgt Merle Y. Strang organized an airlift to Jeju island for thousands of Korean orphans fleeing the advancing North Korean and Chinese soldiers aiming to capture Seoul. The Mustang flown in combat by Col. Hess carried the numeral 18 on the fuselage and the nose was decorated with the Korean inscription "I fly with faith".

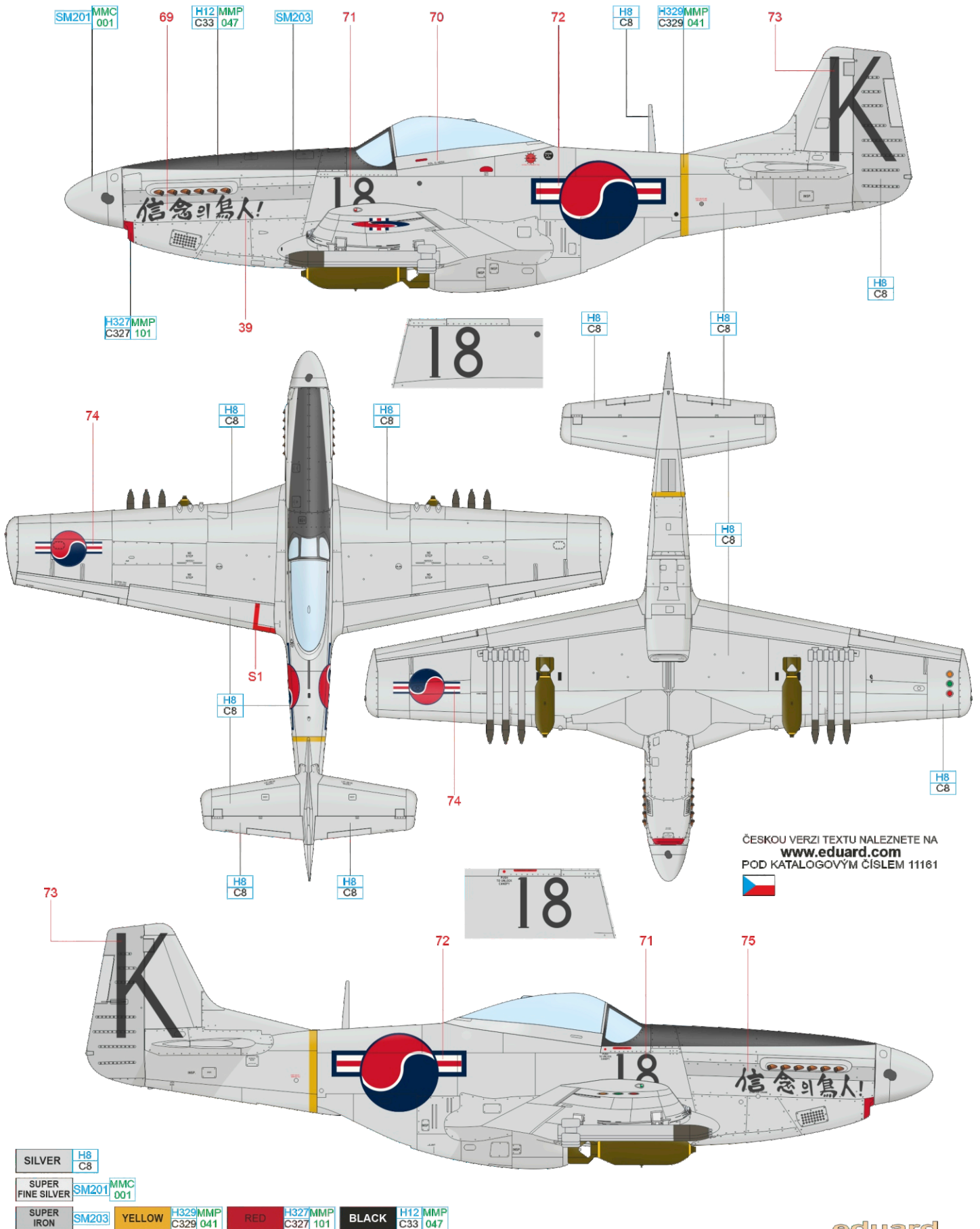

F-51D-25, A68-809 (45-11474), W/Cdr Louis T. Spence, CO of No. 77 Squadron RAAF, Iwakuni, Japan, August 1950

After November 1948 No. 77 Squadron equipped with F-51D Mustang was the only Australian unit incorporated into the British Commonwealth occupation forces and in summer 1950 was preparing to return to Australia. After the outbreak of the war in Korea the unit's transfer was canceled and as per General MacArthur's request attached to 5th AF. No.77 Squadron, led by W/Cdr Lou Spence, flew its first sortie on July 2, 1950 from Iwakuni air base in Japan. Lou Spence, a WWII veteran with No. 3 Squadron RAAF in North Africa and No. 452 Squadron RAAF commander in Australia, led the unit until September 9, 1950, when he was killed during the napalm raid on Angang-ni. It remains unclear if the aircraft crashed into the city due to the enemy fire or pilot's error.

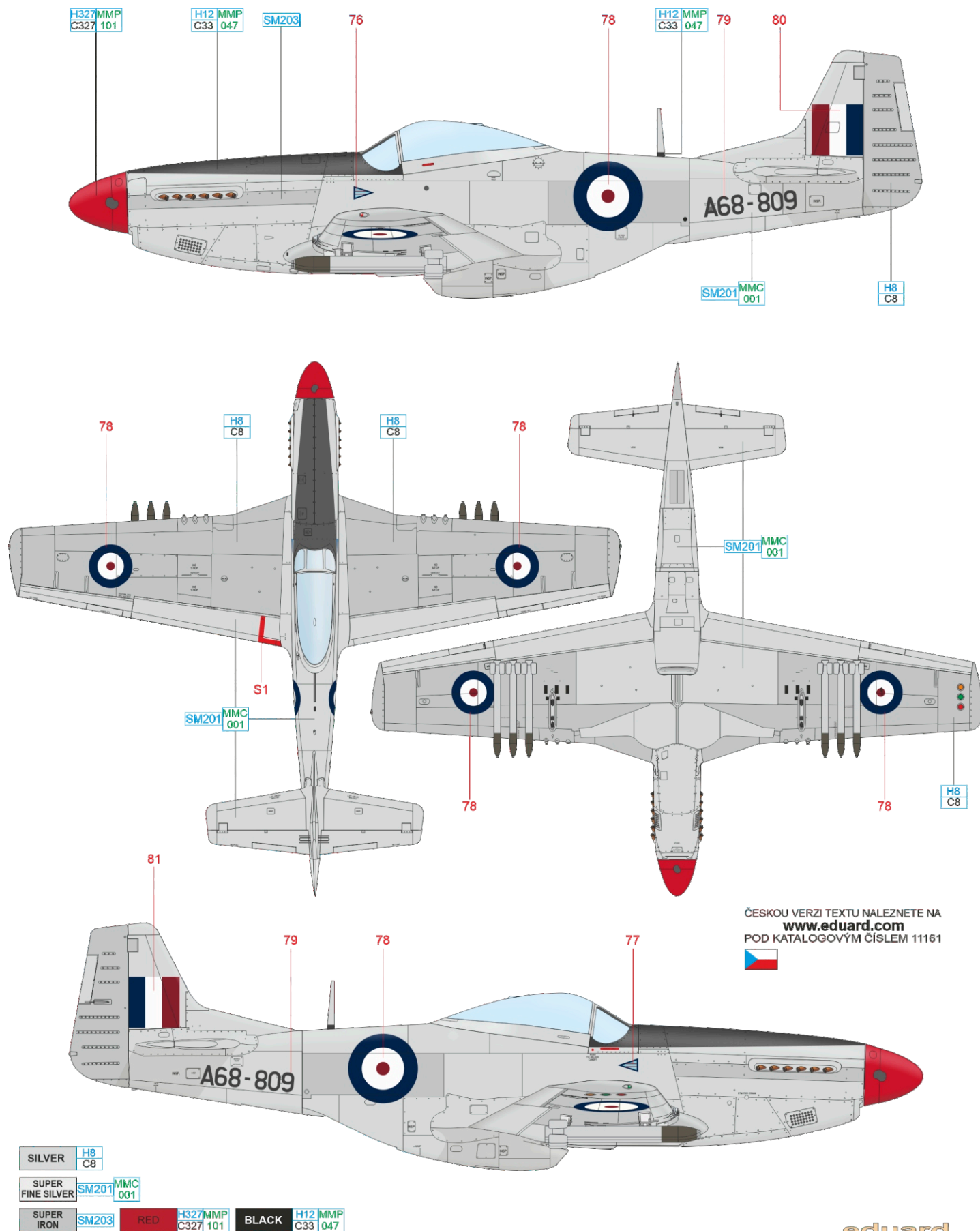

J P-51D-30, 44-74863, No. 2 „Flying Cheetahs“ Squadron SAAF, Chinhae AB (K-10), Korea, 1952

Another unit operating under the USAF command was No. 2 Squadron SAAF manned by volunteer pilots from South Africa. They arrived in Japan aboard a ship on November 1, 1950 and after a necessary conversion training on P-51 the unit led by Commandant Servaas van Bred Theron was incorporated into the 18th FBG. Until the end of the Korean conflict they flew combat missions in support of the ground troops and to destroy the North Korean and Chinese logistics. In February 1953 the unit converted to F-86 Sabre jets. During the Korean war No. 2 Squadron SAAF pilots flew 12,067 combat missions which were mostly the attacks on the ground targets.

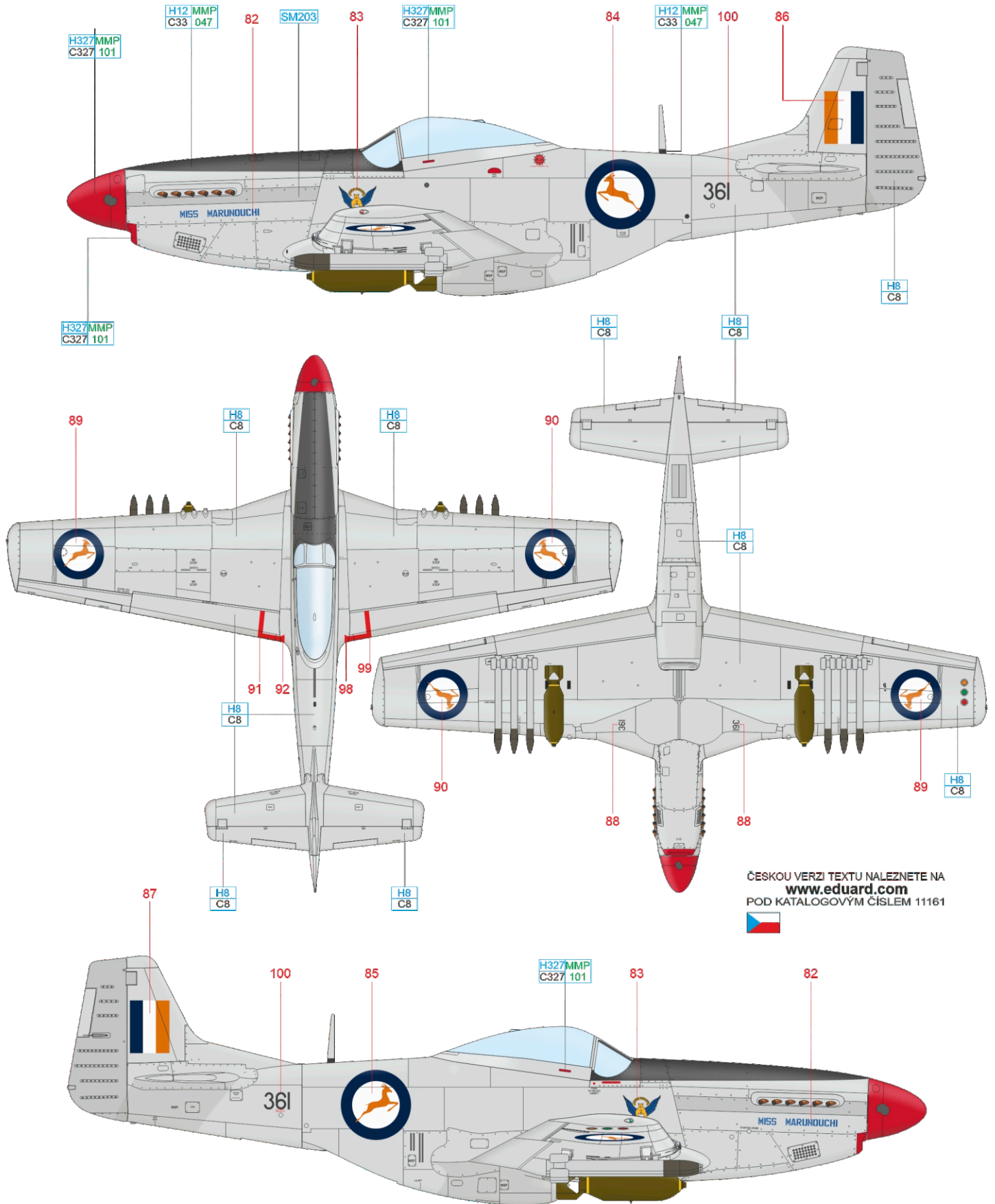

ČESKOU VERZI TEXTU NALEZNETE NA
www.eduard.com
 POD KATALOGOVÝM ČÍSLEM 11161



SILVER	H8 C8
SUPER IRON	SM203
RED	H327/MMP C327 101
BLACK	H12/MMP C33 047

F-6D/K, RF-51 ALUMINIUM LACQUER PAINTED AREAS

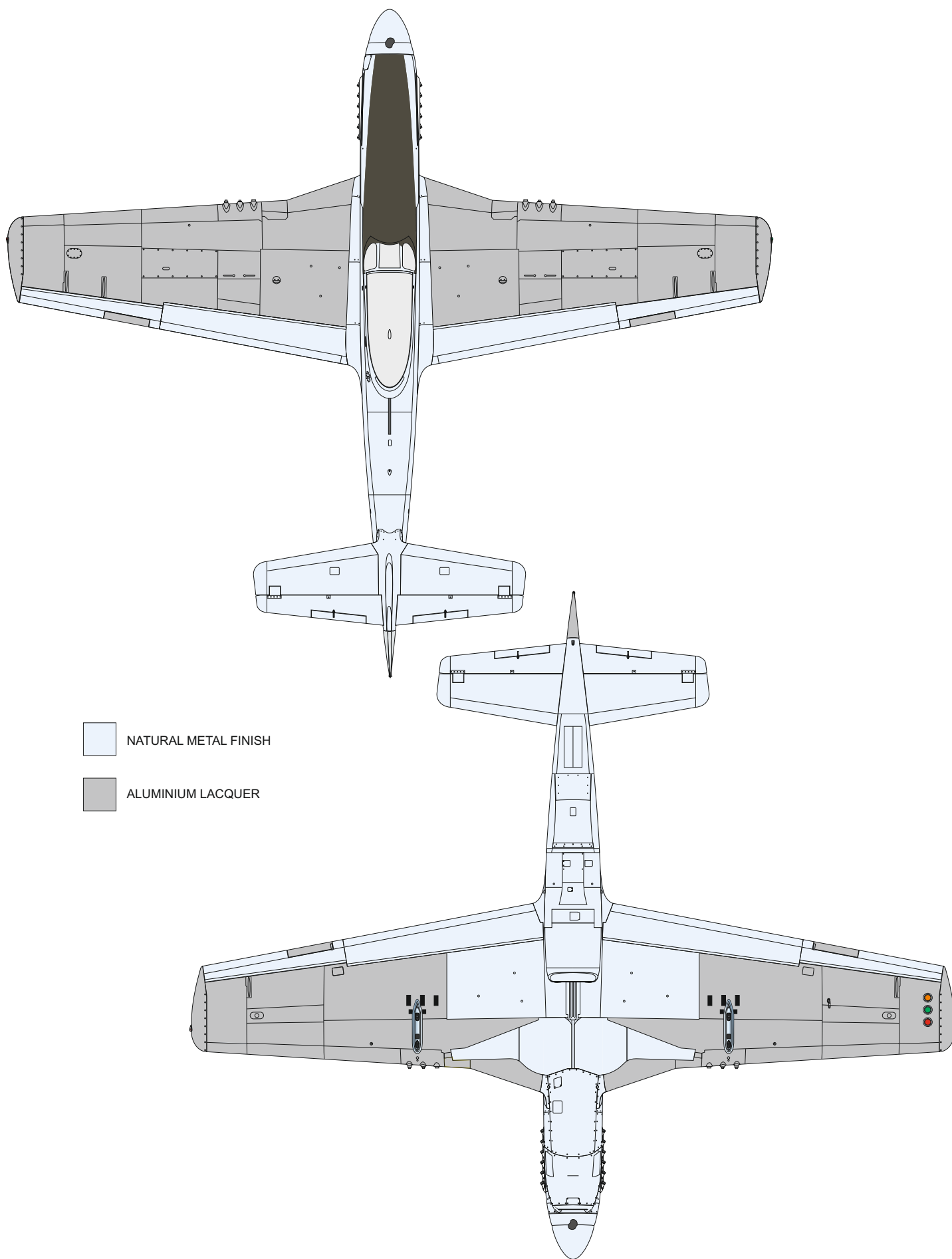

OVERHAULED MUSTANGS WERE
OVERPAINTED WITH ALUMINIUM COLOR

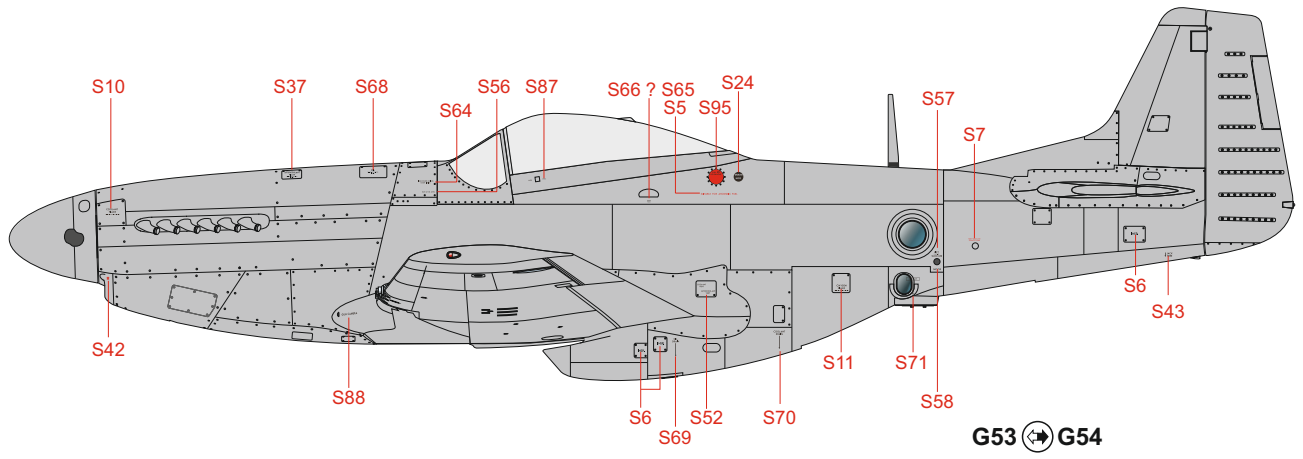

G53 ↔ G54

H329 MMP
C329 041

H12 MMP
C33 047

S76
S27 ?
S31

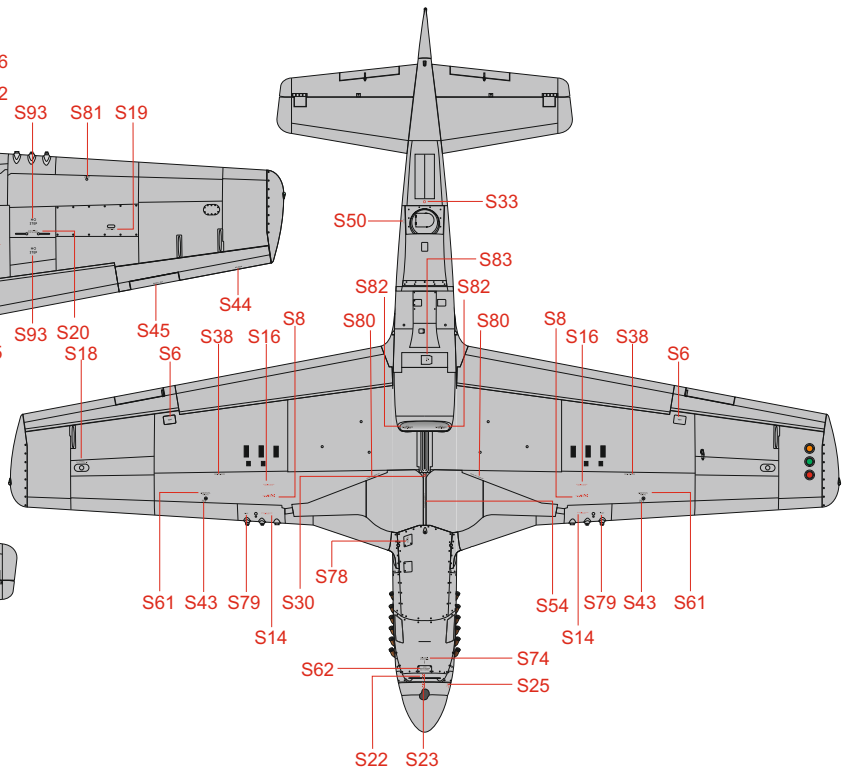
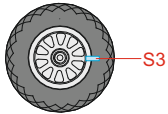
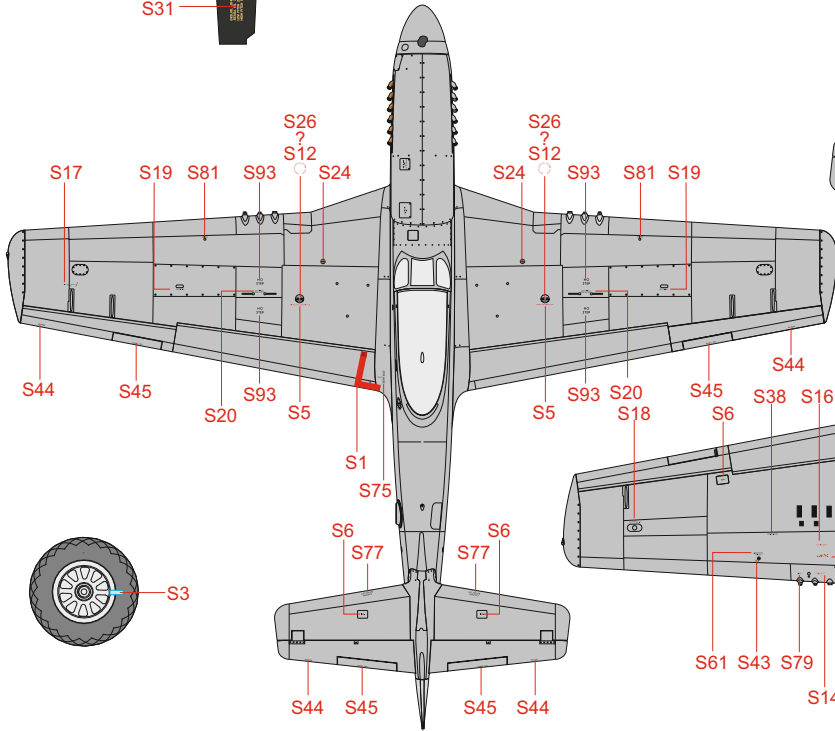
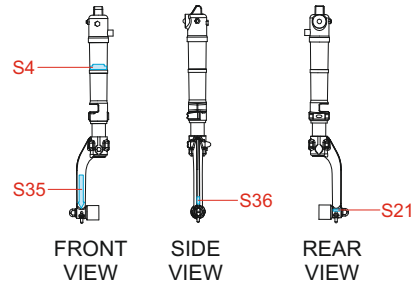
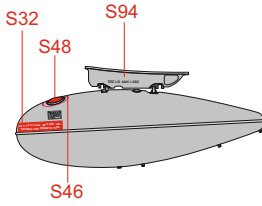

S63 - MARKINGS E, F, G ONLY

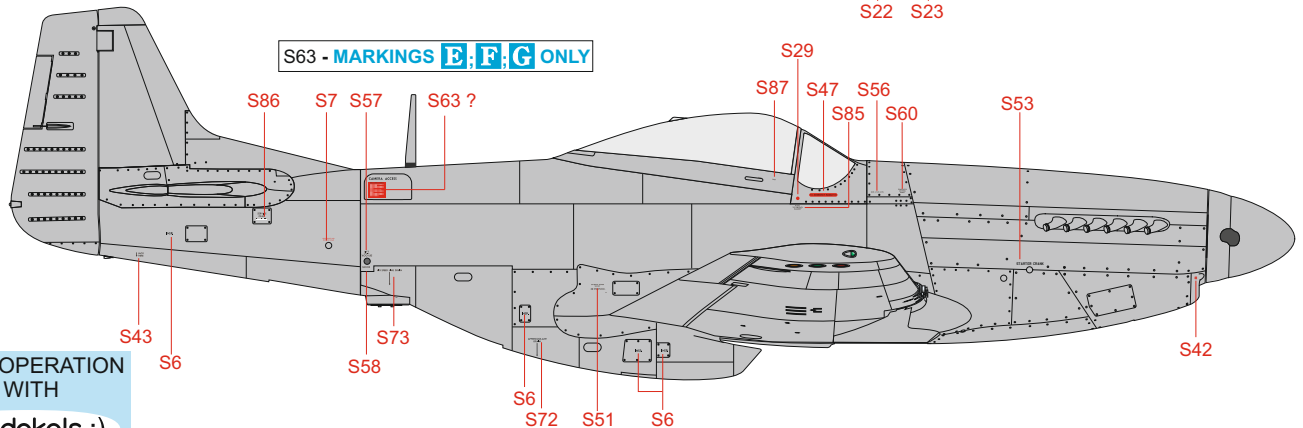

IN COOPERATION WITH
fündekals :)