

eduard

LIMITED



Tornado IDS

INSTRUCTION SHEET

1/48

11165-NAV1

ATTENTION



UPOZORNĚNÍ



ACHTUNG



ATTENTION



注意



Carefully read instruction sheet before assembling. When you use glue or paint, do not use near open flame and use in well ventilated room. Keep out of reach of small children. Children must not be allowed to suck any part, or pull vinyl bag over the head.



Před započatím stavby si pečlivě prostudujte stavební návod. Při používání barev a lepidel pracujte v dobře větrané místnosti. Lepidla ani barvy nepoužívejte v blízkosti otevřeného ohně. Model není určen malým dětem, mohlo by dojít k požití drobných dílů.

INSTRUCTION SIGNS * INSTR. SYMBOLS * INSTRUKTION SINNBILDEN * SYMBOLES * 記号の説明

OPTIONAL
VOLBABEND
OHNOUTSAND
BROUSITOPEN HOLE
VYVRTAT OTVORSYMETRICAL ASSEMBLY
SYMETRICKÁ MONTÁŽREMOVE
ODRÍZNOUTREVERSE SIDE
OTOČITAPPLY EDUARD MASK
AND PAINT
POUŽÍT EDUARD MASK
NABARVIT

PARTS



DÍLY



TEILE



PIÈCES



部品

PLASTIC PARTS

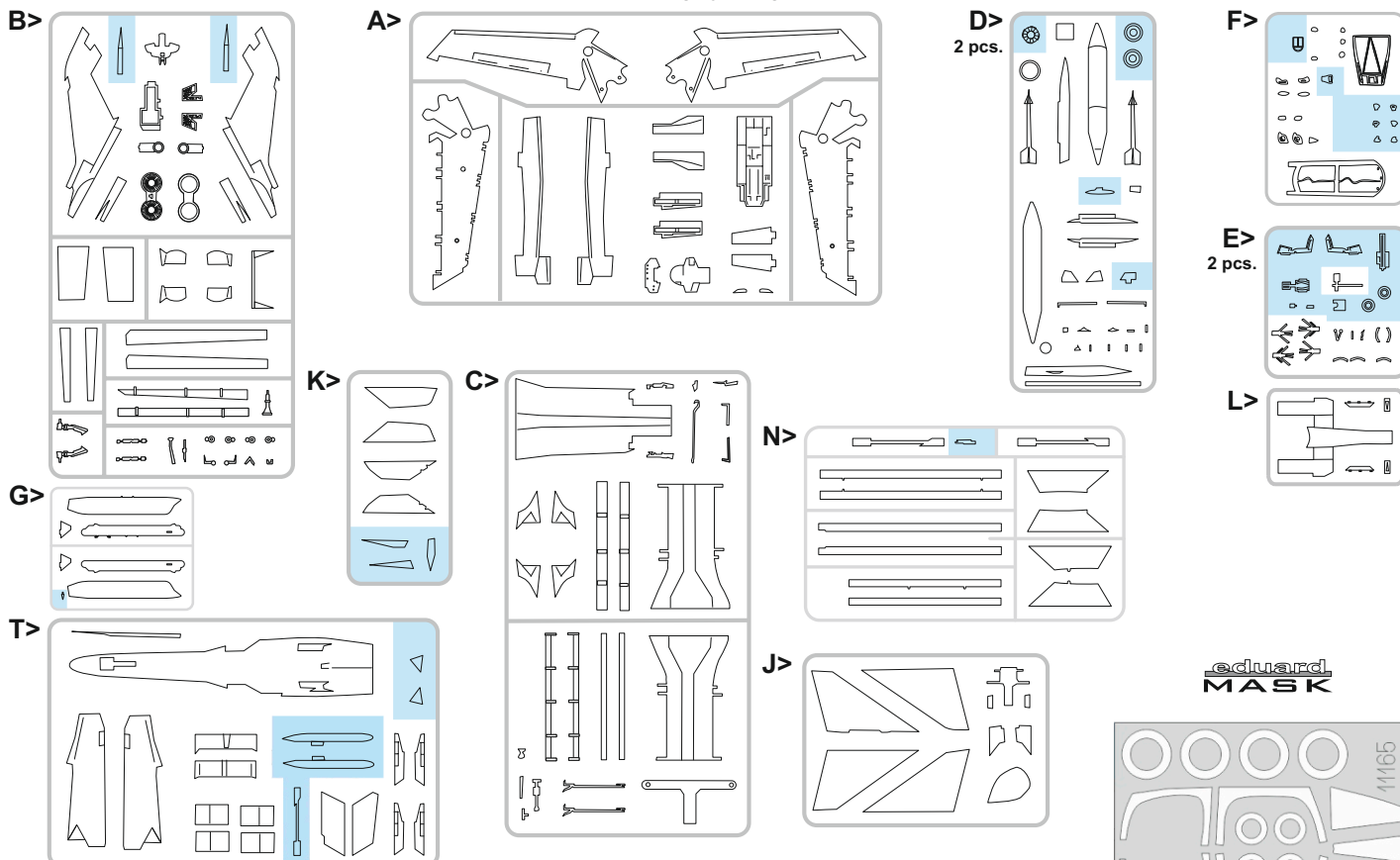

PE - PHOTO ETCHED DETAIL PARTS

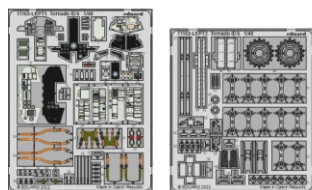

FILM



RP - RESIN PARTS



R1 2pcs.

R2

R3

R4 2pcs.

R5 2pcs.

R6 2pcs.

R7 2pcs.

R8 2pcs.

R9 2pcs.

R10 2pcs.

R11 2pcs.

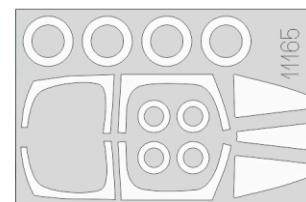
eduard
MASK

1165

-Parts not for use. -Teile werden nicht verwendet. -Pièces à ne pas utiliser. -Tyto díly nepoužívejte při stavbě. - 使用しない部品

COLOURS



BARVY



FARBEN



PEINTURE



色

GSI Creos (GUNZE)		MISSION MODELS	
AQUEOUS	Mr.COLOR	PAINTS	
H2	C2	MMP-047	BLACK
H3	C3	MMP-003	RED
H11	C62	MMP-001	FLAT WHITE
H12	C33	MMP-047	FLAT BLACK
H44	C51		FLESH
H52	C12	MMP-091	OLIVE DRAB
H53	C13		NEUTRAL GRAY
H54	C365		NAVY BLUE
H68	C36	MMP-049	RLM74 DARK GRAY
H69	C37	MMP-066	RLM75 GRAY
H77	C137	MMP-040	TIRE BLACK
H82	C31		DARK GRAY
H90	C47		CLEAR RED
H94	C138		CLEAR GREEN
H301	C301	MMP-099	GRAY
H303	C303	MMP-066	GREEN
H305	C305	MMP-084	GRAY

GSI Creos (GUNZE)			MISSION MODELS
AQUEOUS	Mr.COLOR	PAINTS	
H306	C306	MMP-118	MEDIUM GRAY
H307	C307	MMP-074	GRAY
H308	C308	MMP-073	GRAY
H309	C309	MMP-031	GREEN
H317	C317	MMP-064	GRAY
H331	C331		DARK SEAGRAY
H334	C334	MMP-102	BARLEY GRAY
H338	C338	MMP-116	LIGHT GRAY
H421	C121	MMP-052	BROWN VIOLET
Mr.METAL COLOR		METALLICS	
MC211			CHROME SILVER
MC213		MMM-006	STAINLESS
MC214		MMM-001	DARK IRON
MC218		MMM-001	ALUMINIUM
Mr.COLOR SUPER METALLIC		METALLICS	
SM201		MMC-001	SUPER FINE SILVER

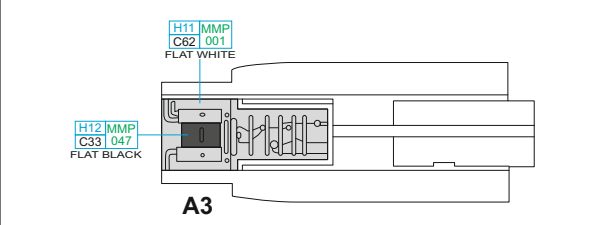
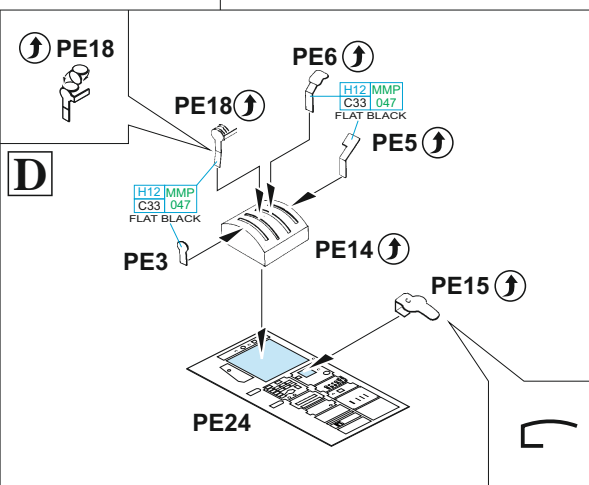
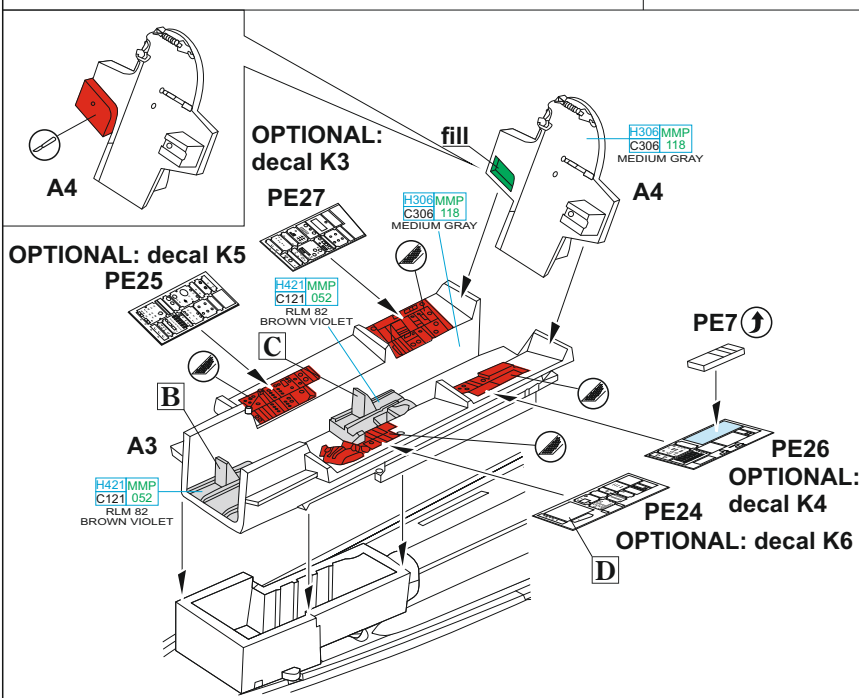
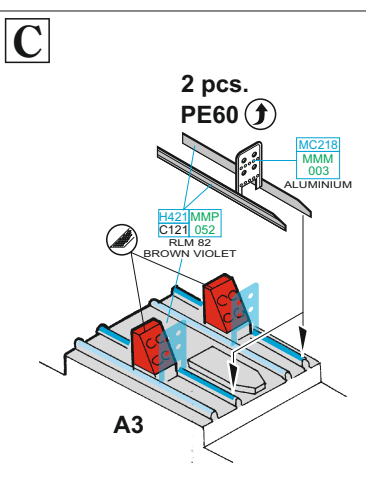
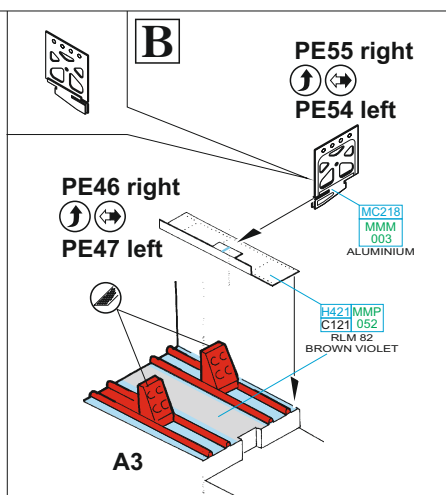
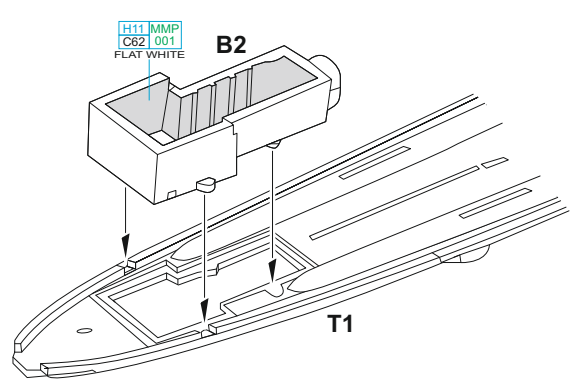
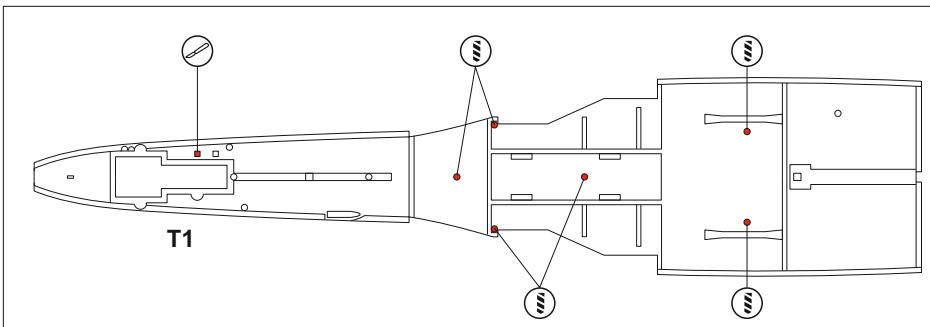
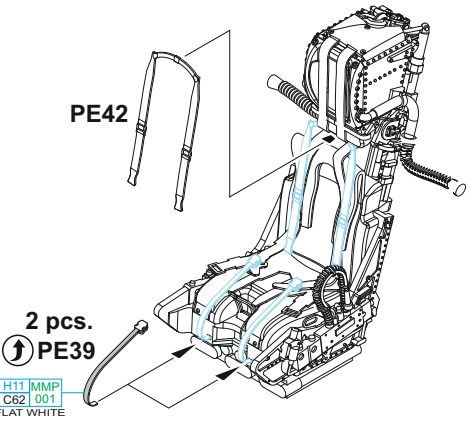
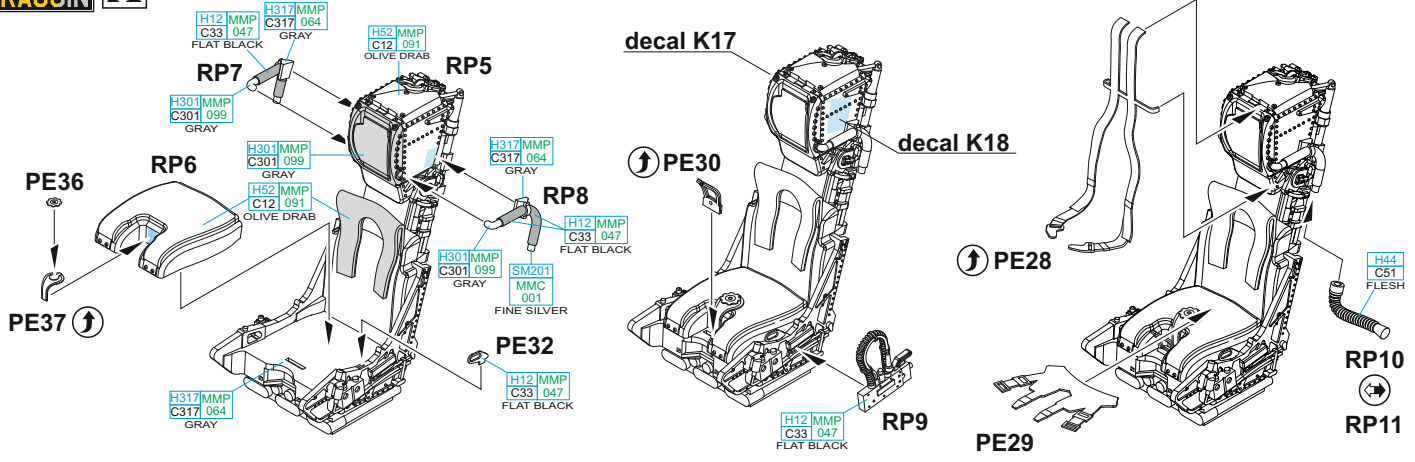

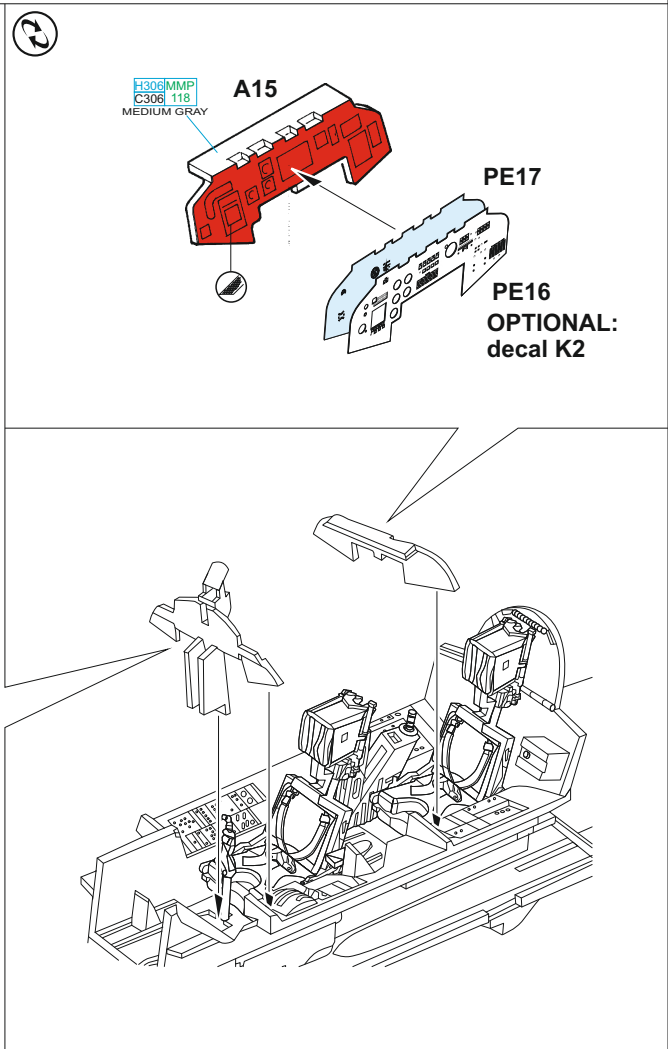
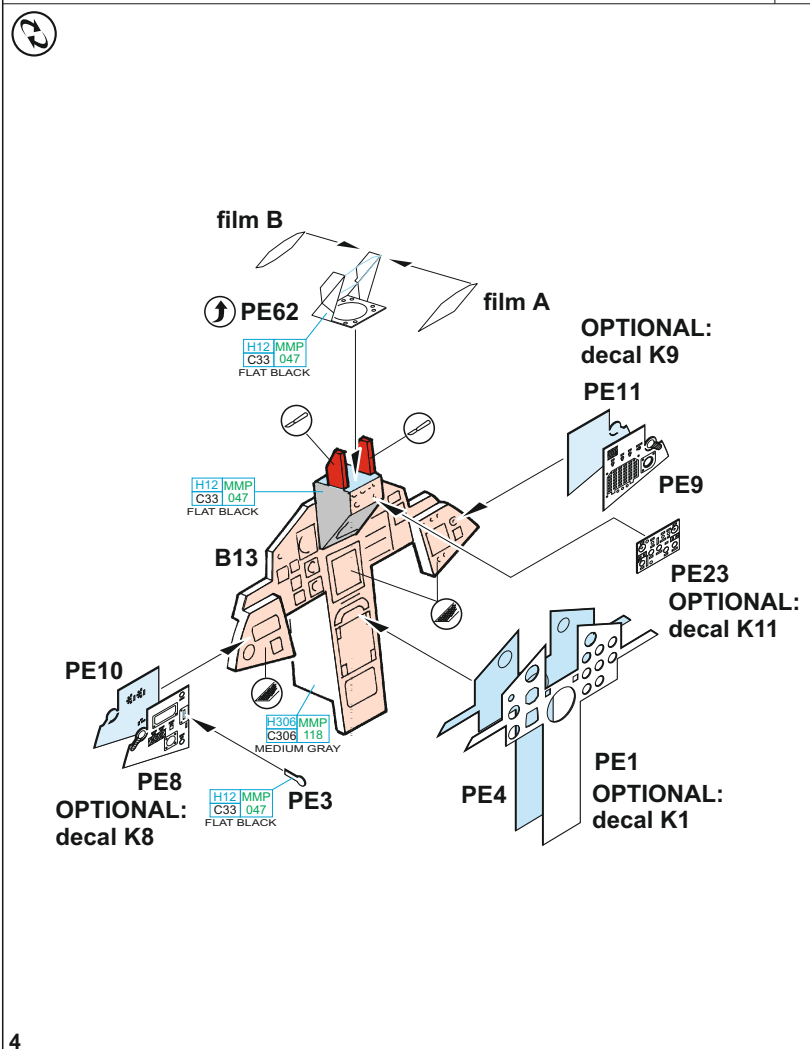
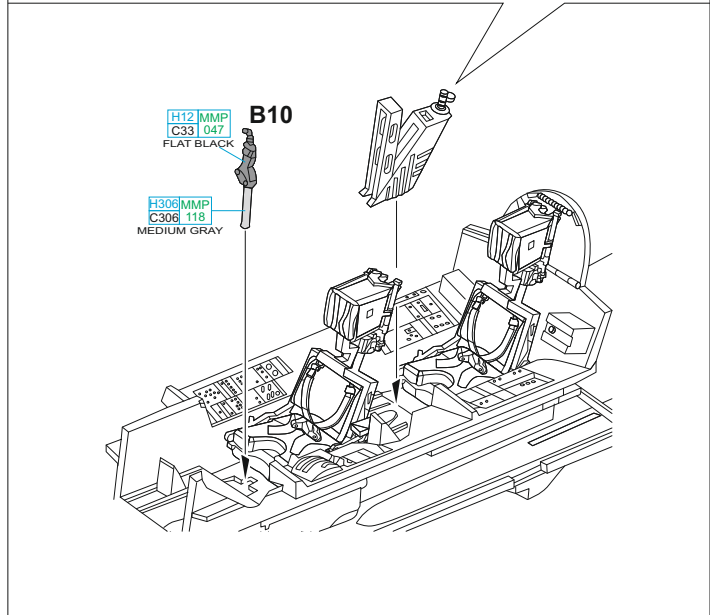
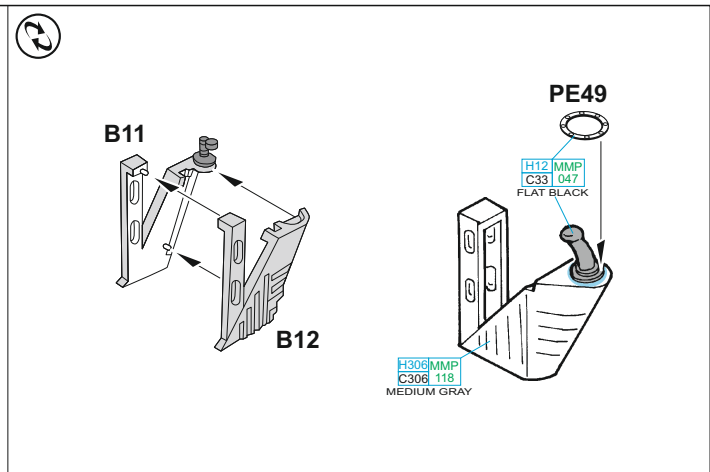
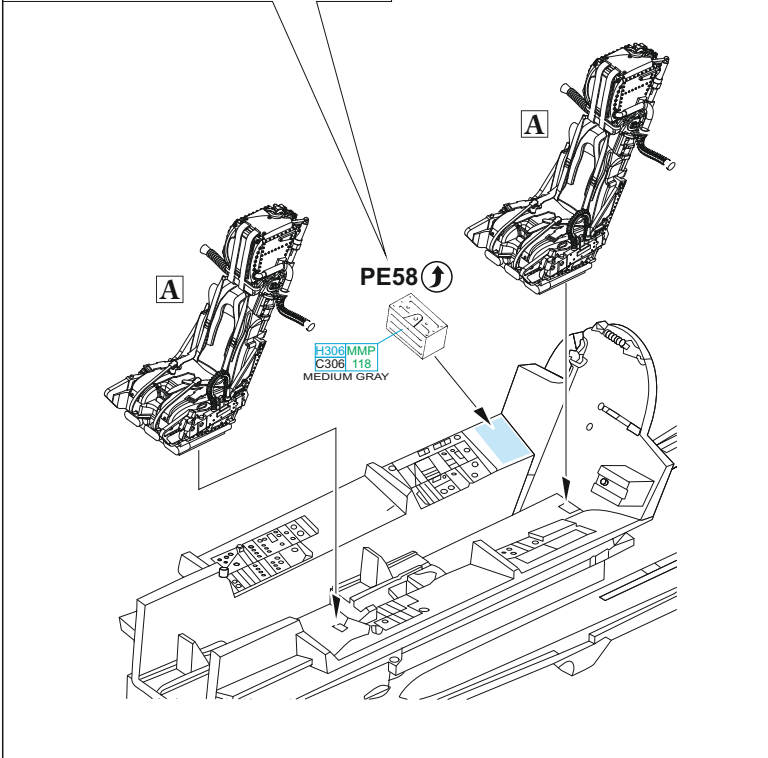
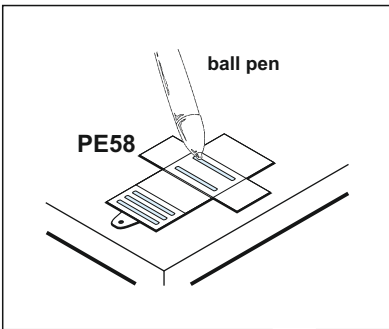

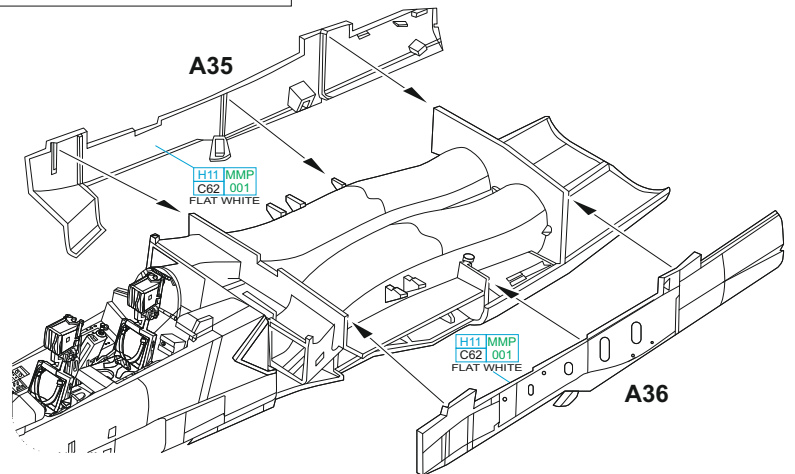
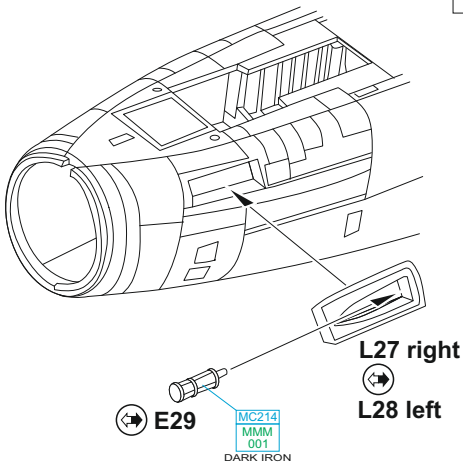
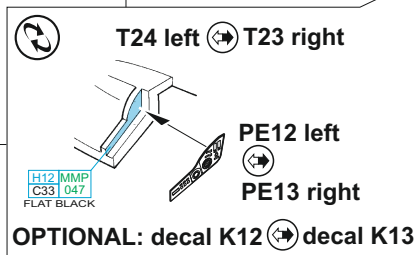
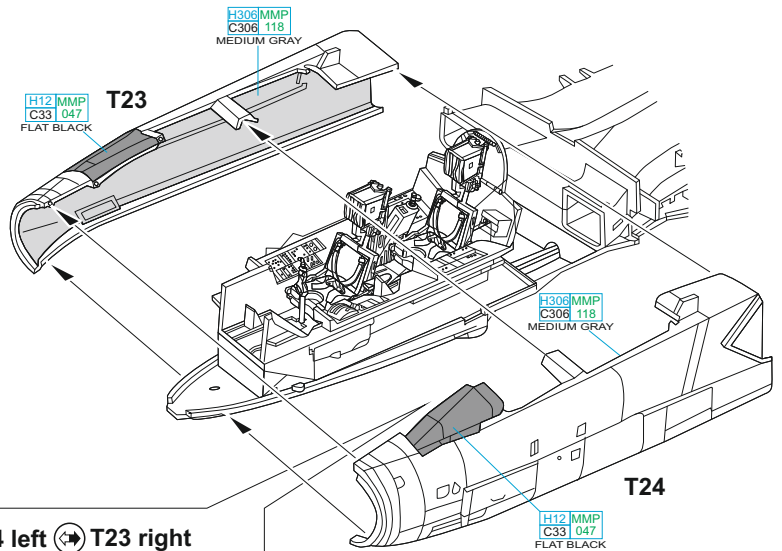
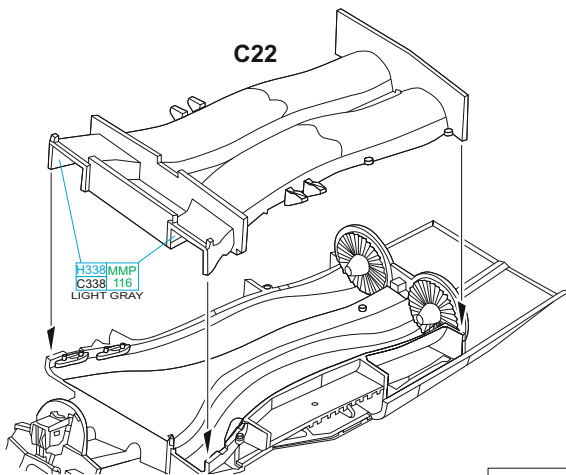
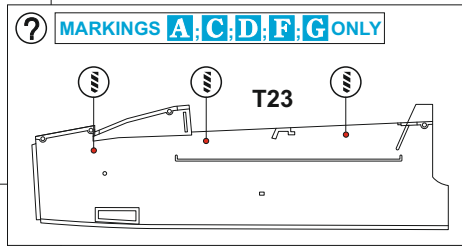
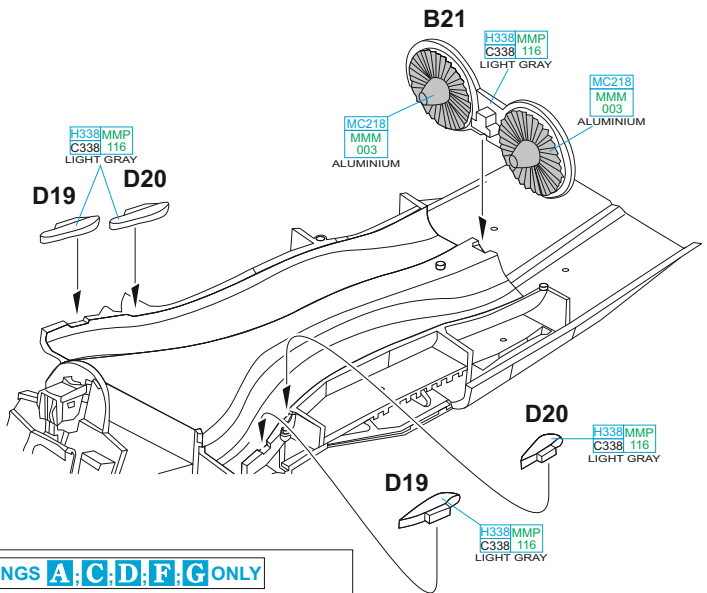
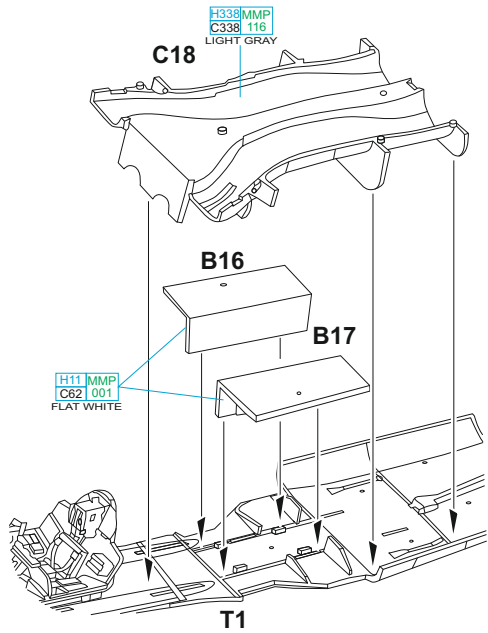

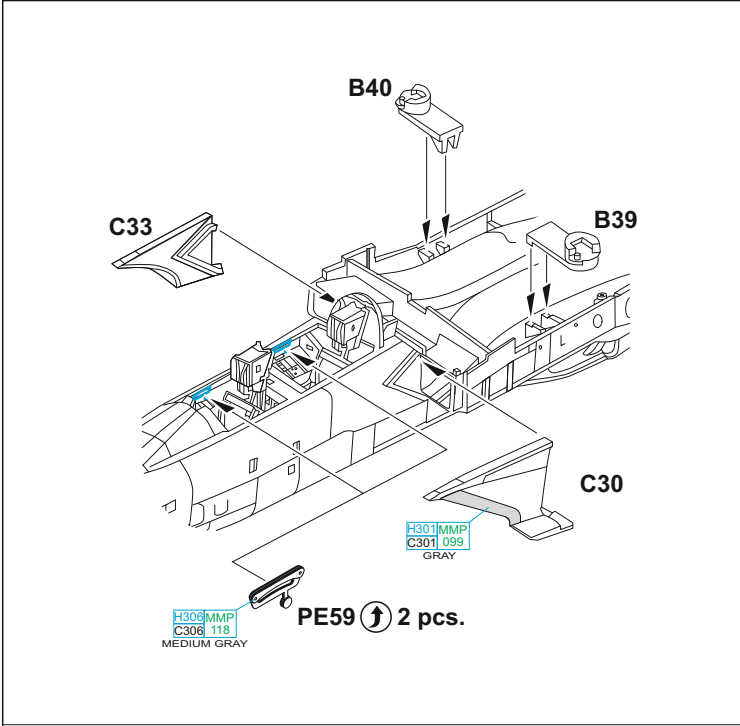

Flaps up

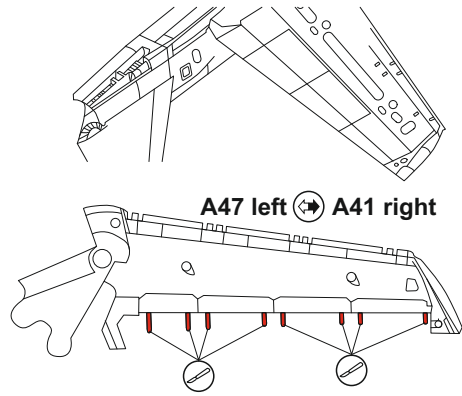

Flaps down

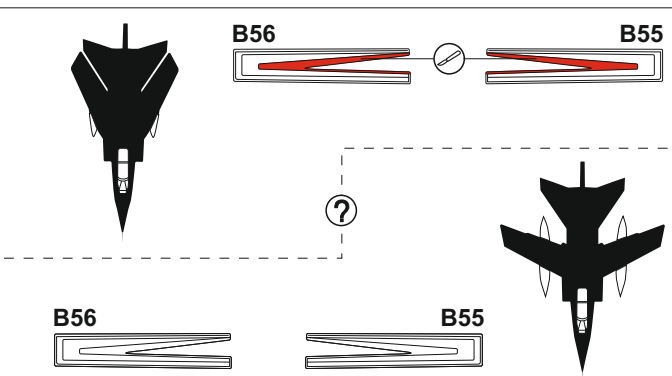
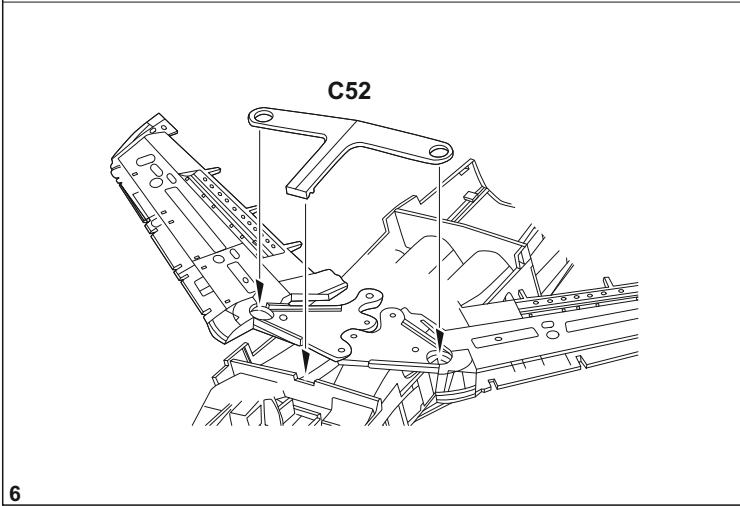
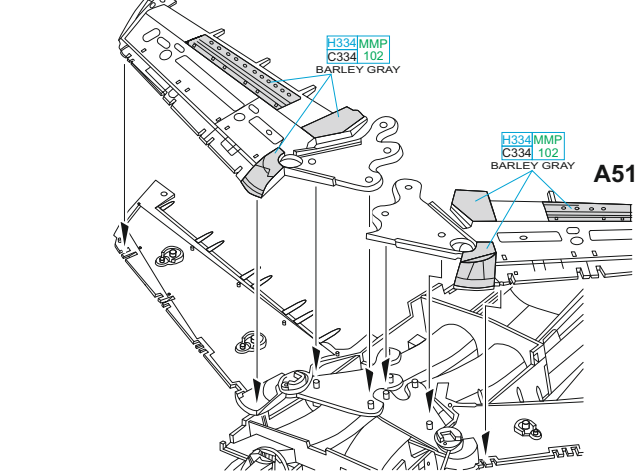
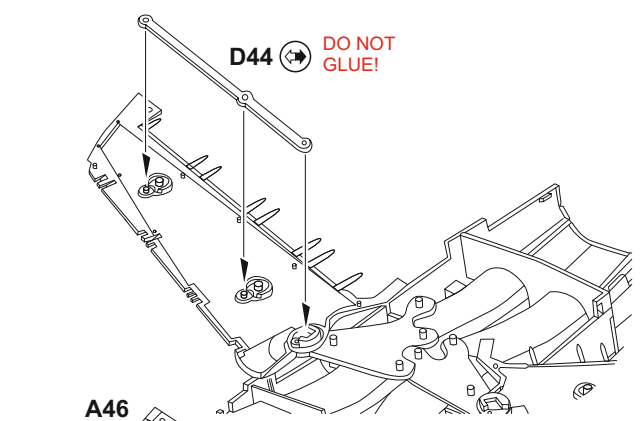
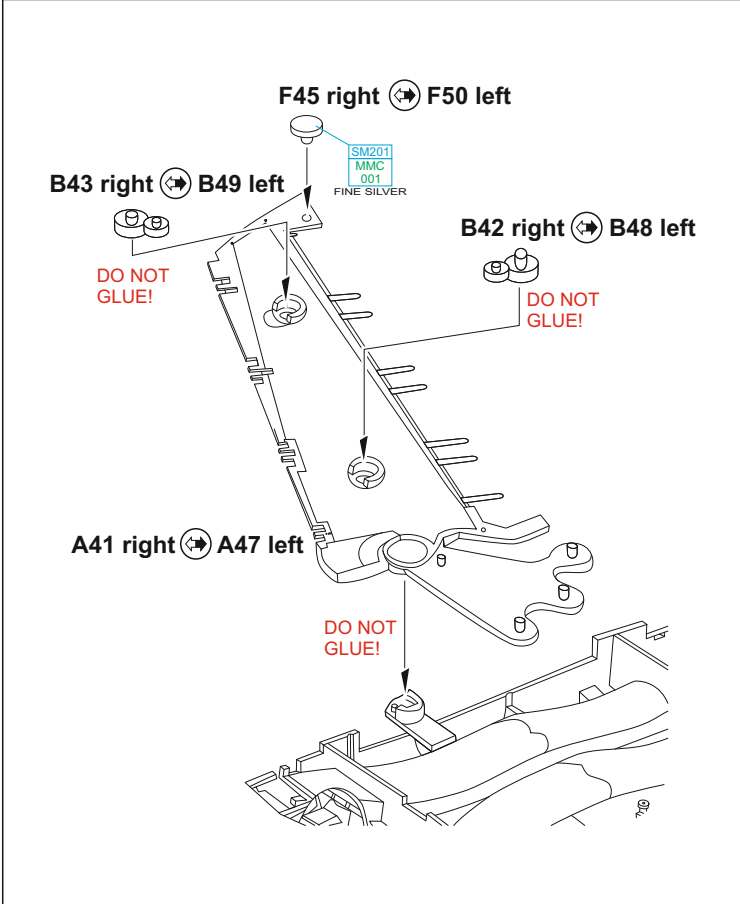
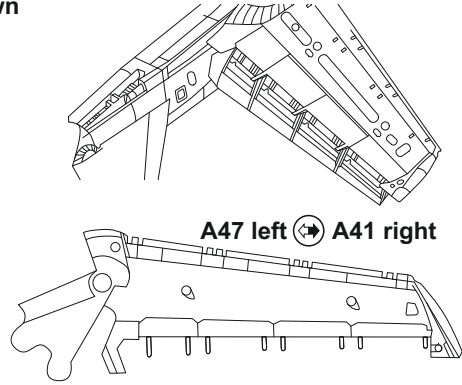

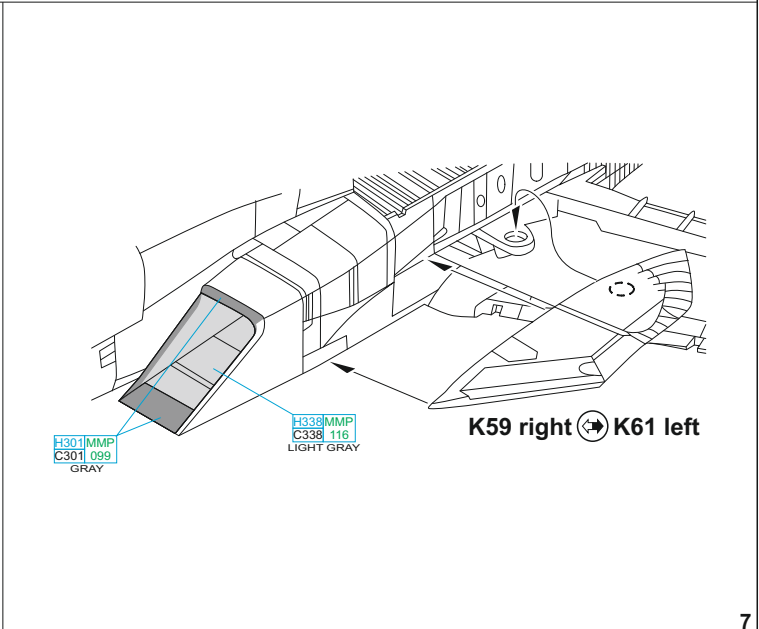
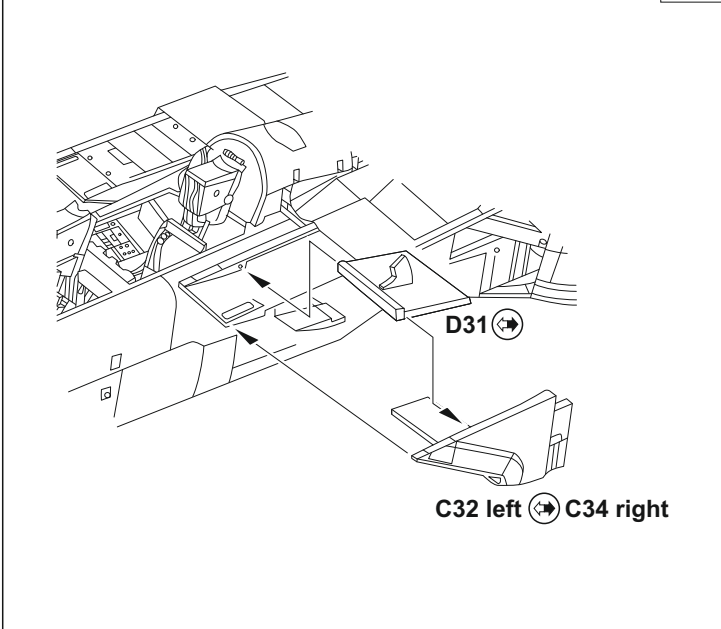
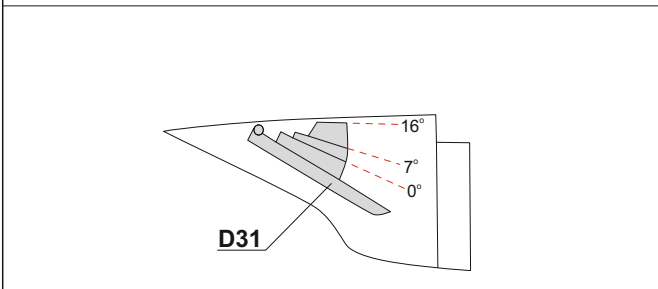
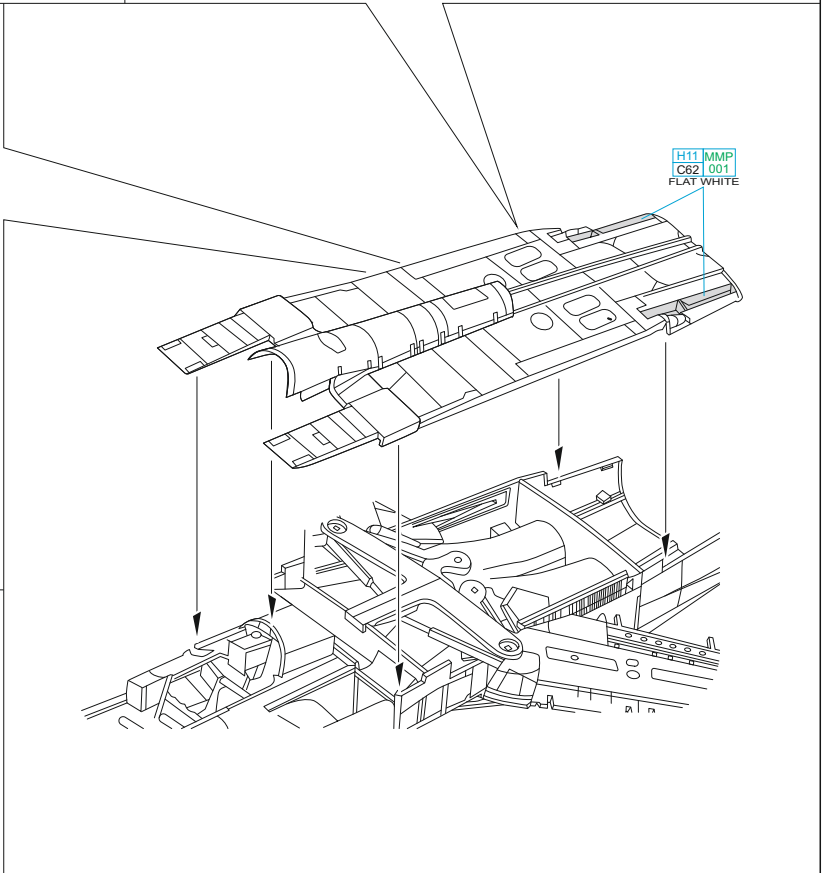
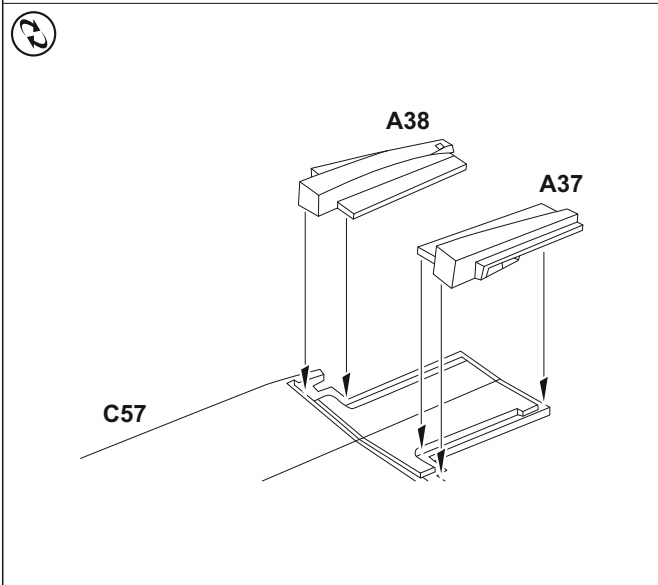
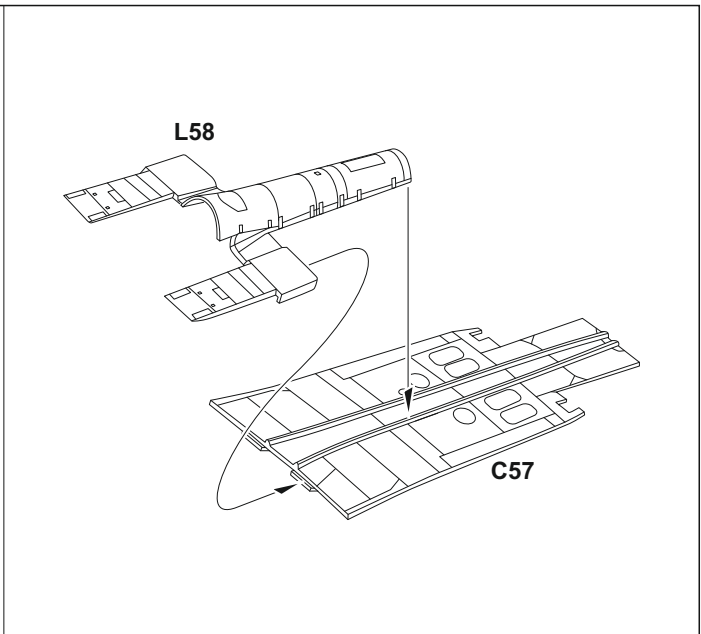
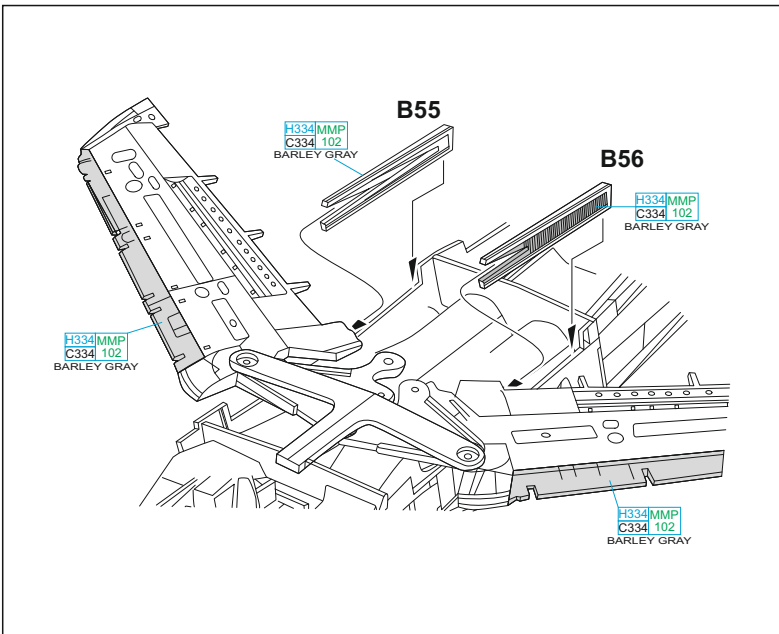

K62 left ↔ K60 right

DO NOT
GLUE!

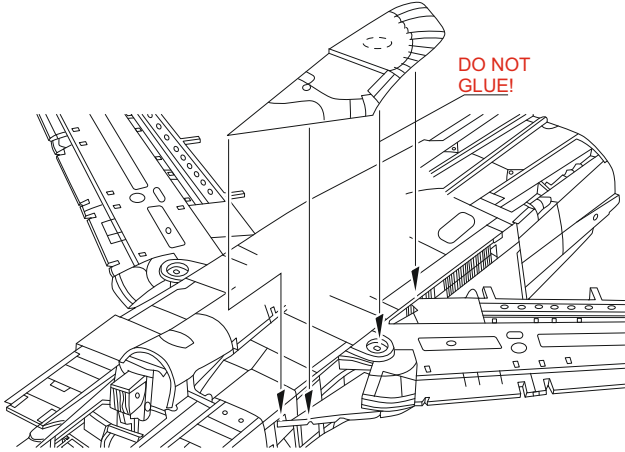

T65

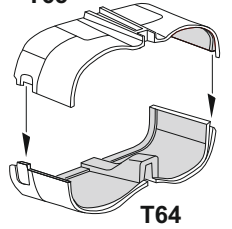

T64

DO NOT
GLUE!

E63

DO NOT
GLUE!

E63

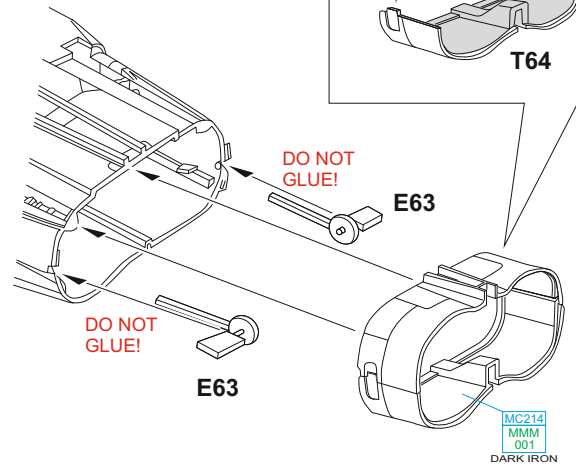

MC214
MMM
001
DARK IRON

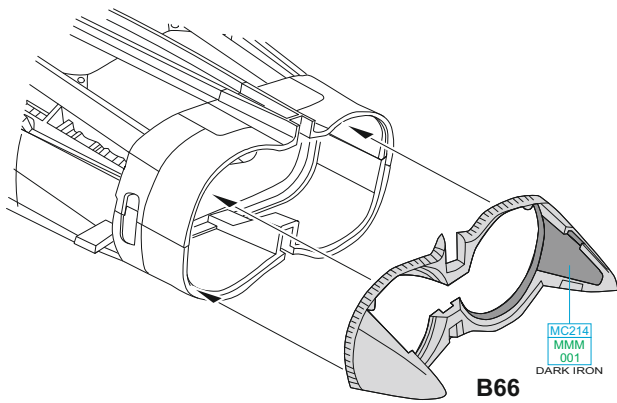

B66

MC214
MMM
001
DARK IRON

T70

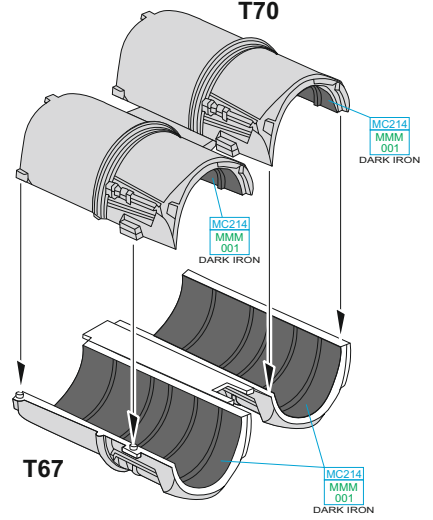

MC214
MMM
001
DARK IRON

MC214
MMM
001
DARK IRON

T67

MC214
MMM
001
DARK IRON

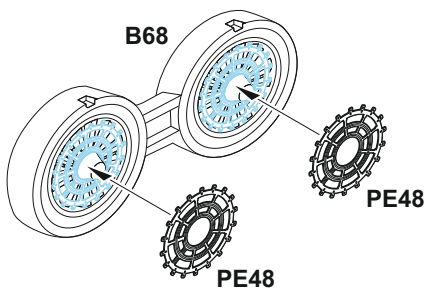

B68

PE48

PE48

MC214
MMM
001
DARK IRON

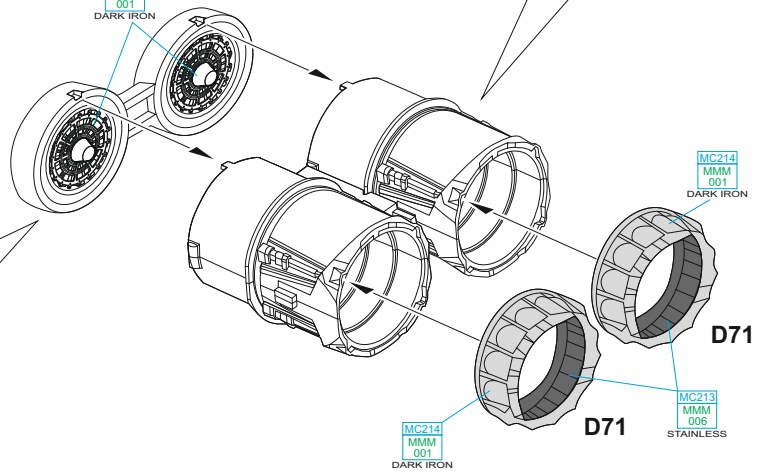

MC214
MMM
001
DARK IRON

D71

MC214
MMM
001
DARK IRON

D71

MC213
MMM
005
STAINLESS

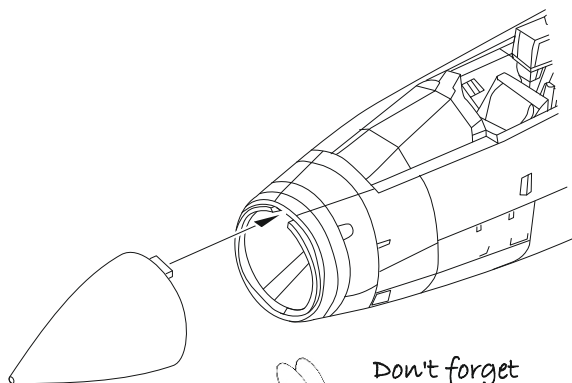
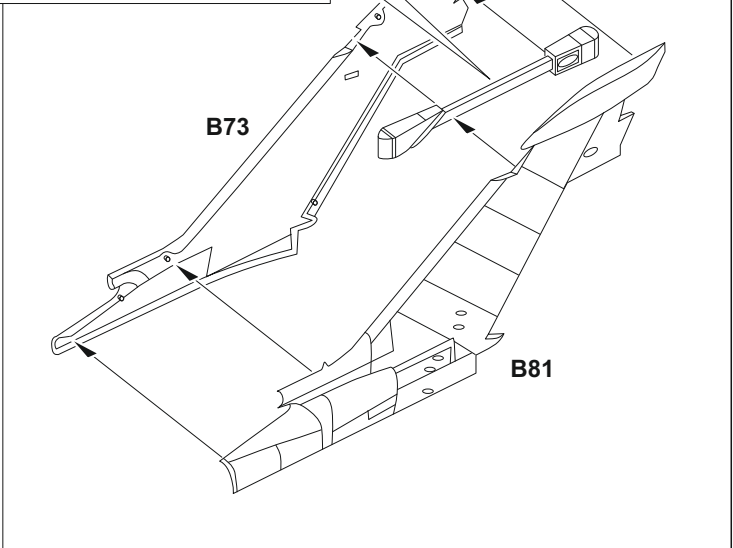
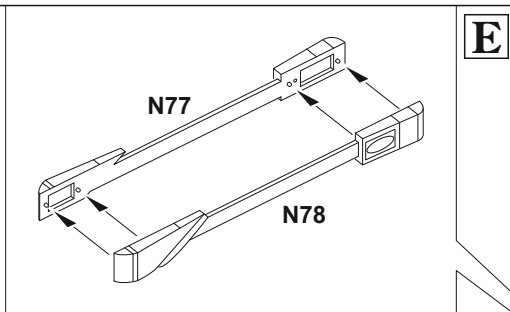
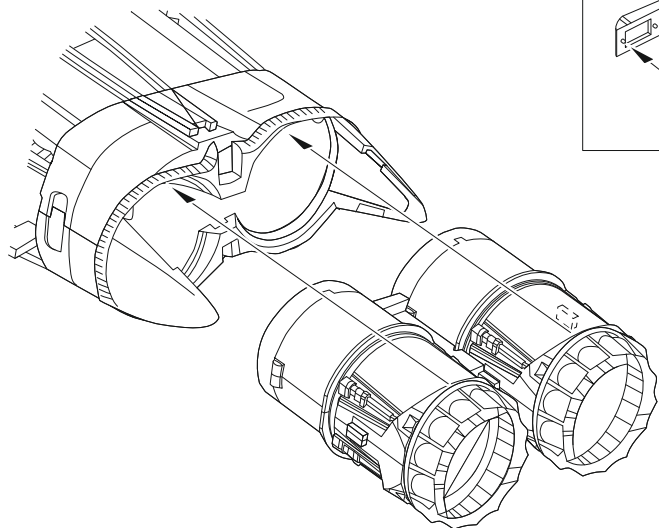

Don't forget
to add the nose
weight balance!

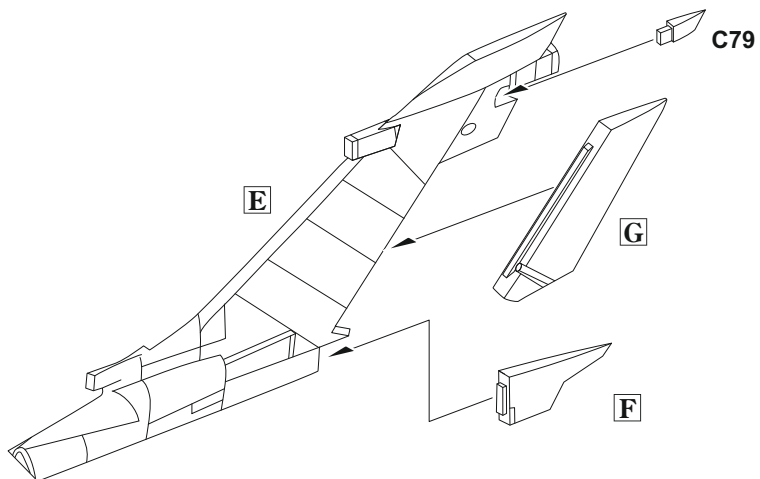
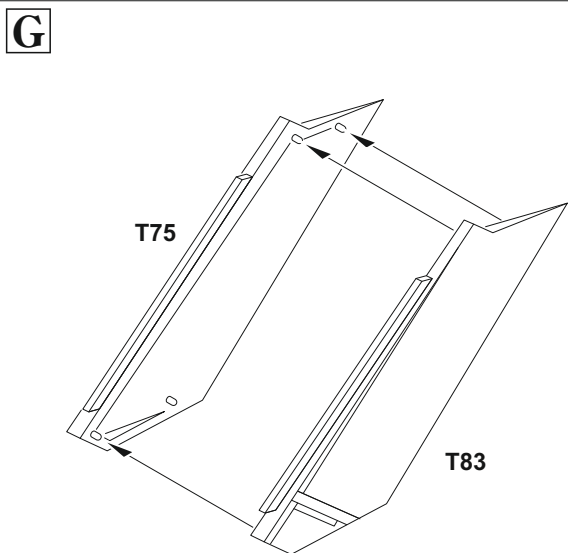
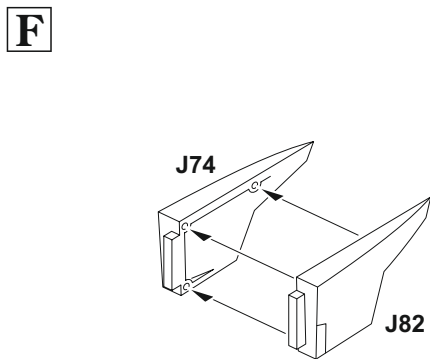

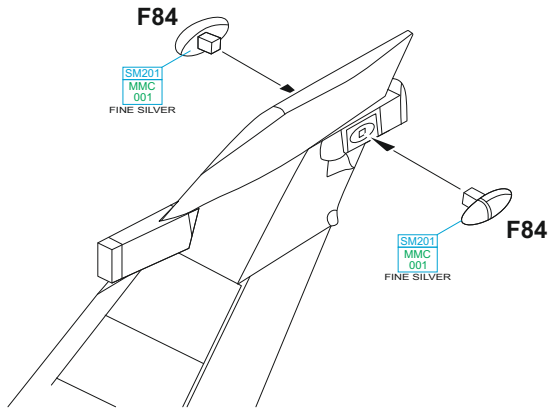

H 2 pcs.

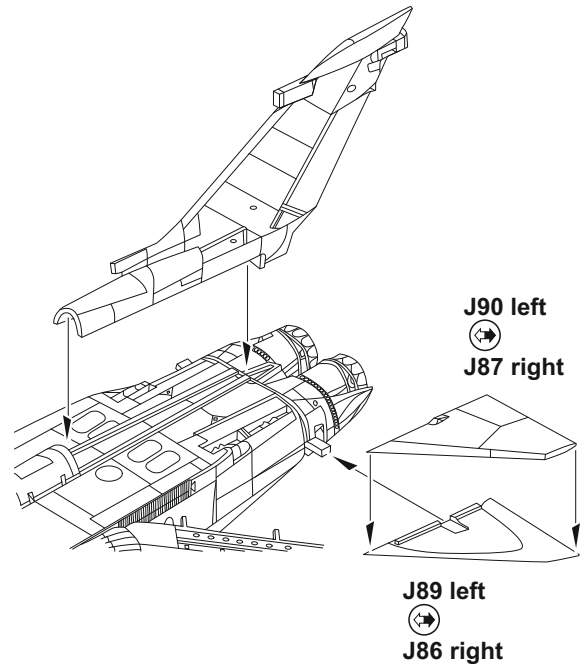
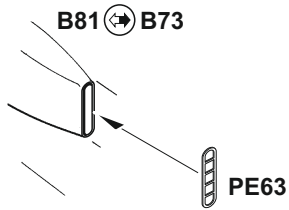

Slats up

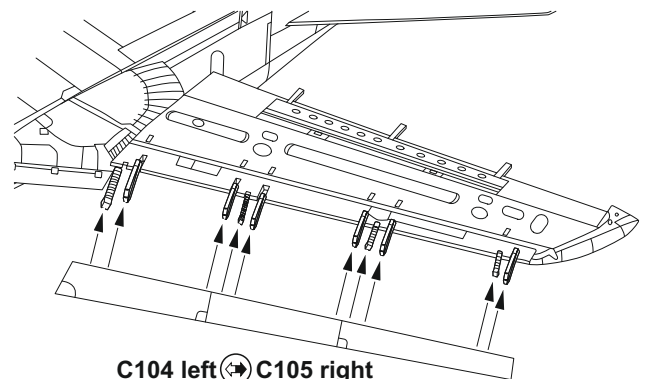
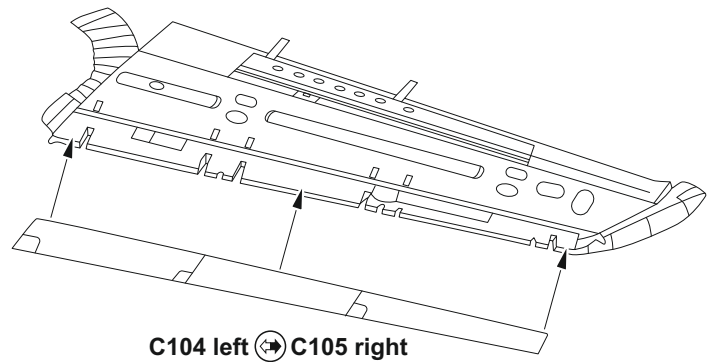

Slats down

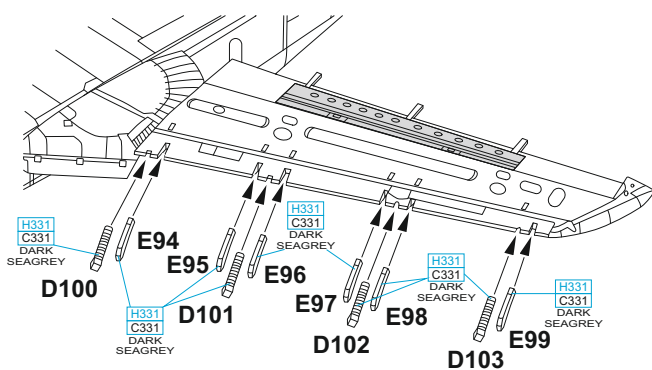

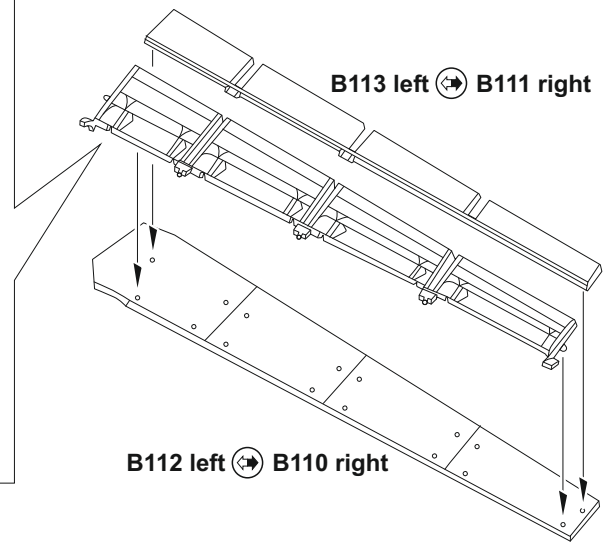
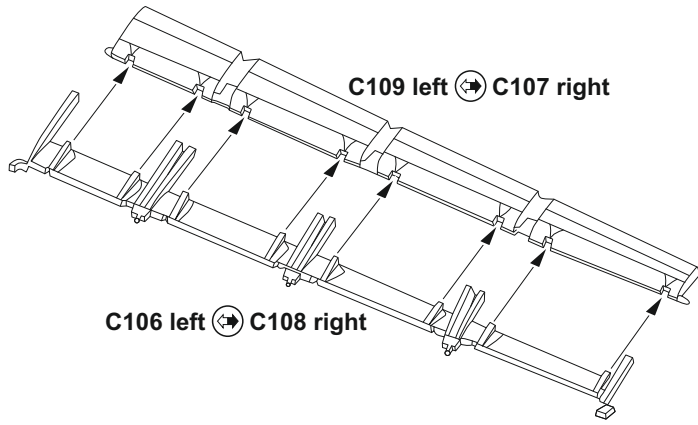

Flaps down

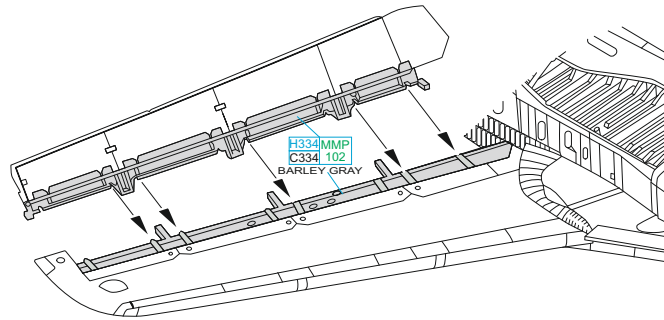

Flaps up

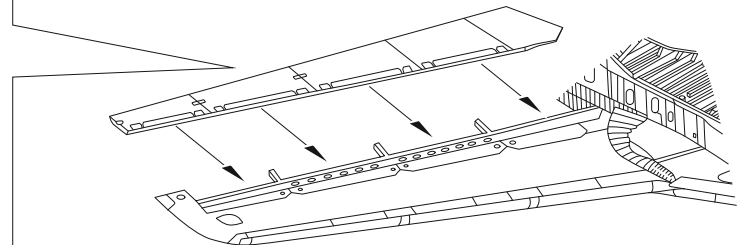
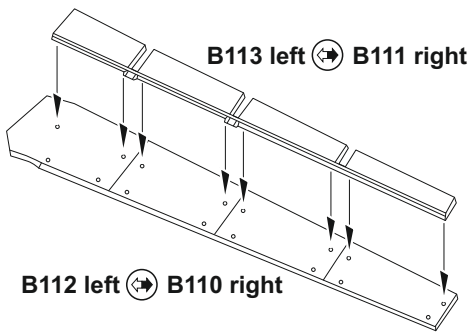

?

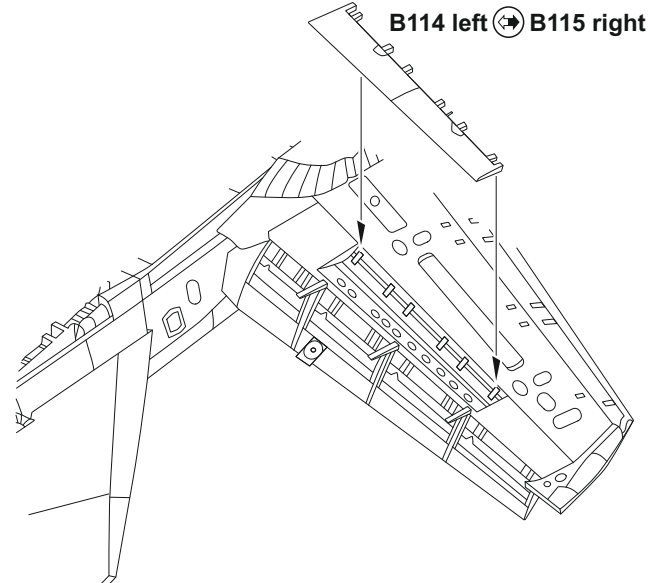
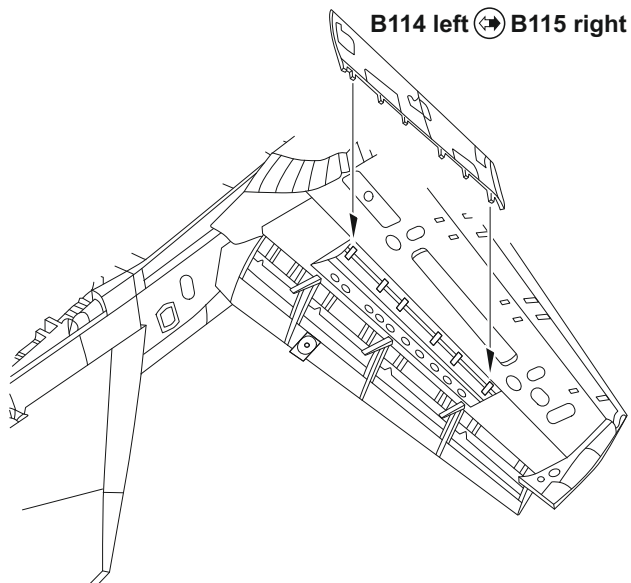

?

J

A37 right

A38 left

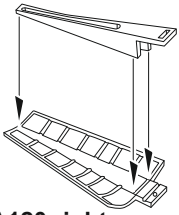

A120 right

A118 left



D117

J

**H338 MMP
C338 116
LIGHT GRAY**

**SM201
MMC
001
FINE SILVER**

J

D117

**H11 MMP
C62 001
FLAT WHITE**

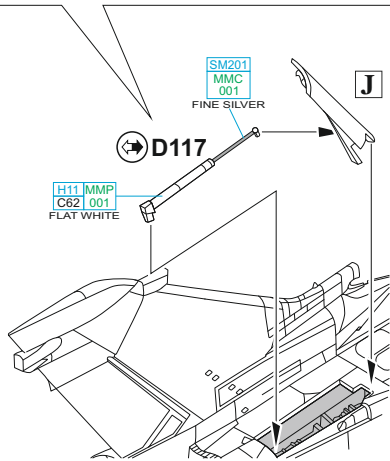

?

A120 right **A118 left**

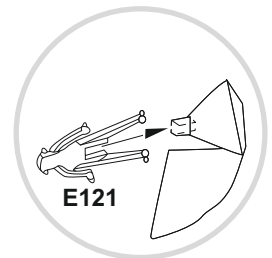
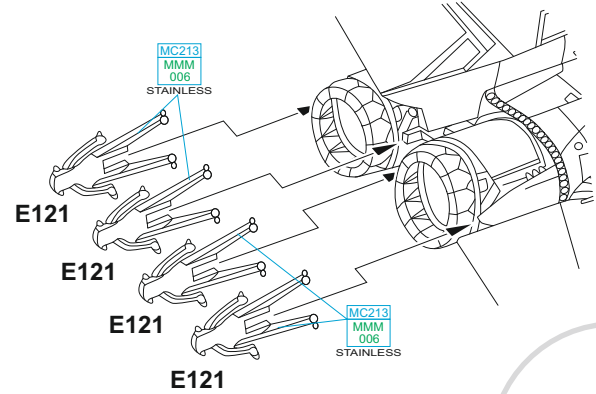
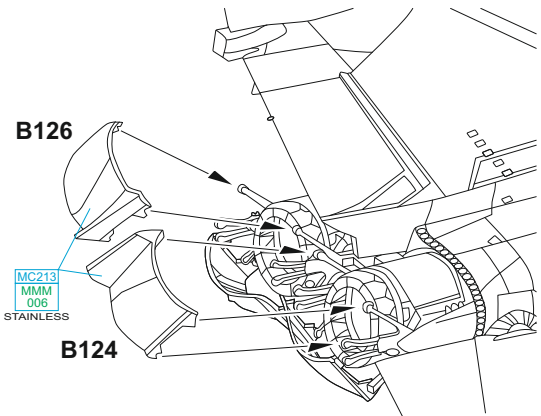
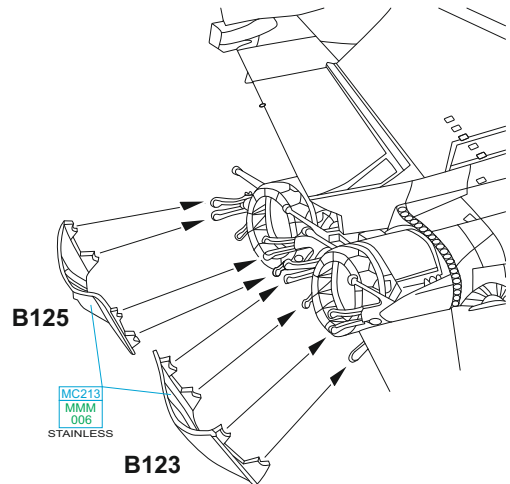
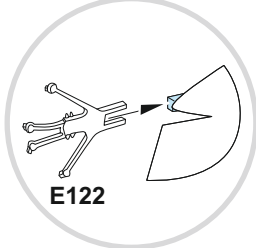
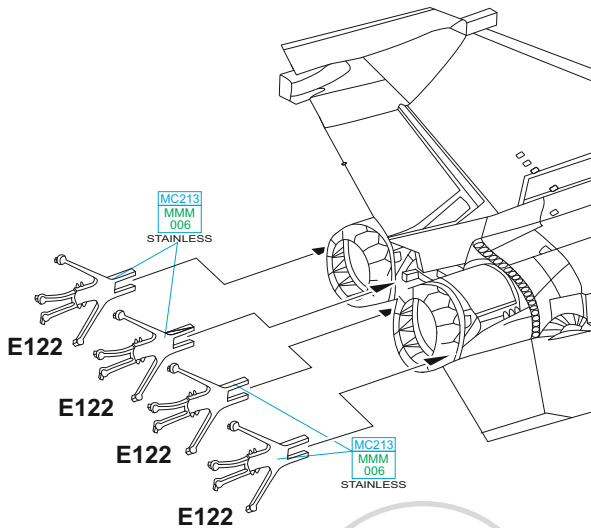
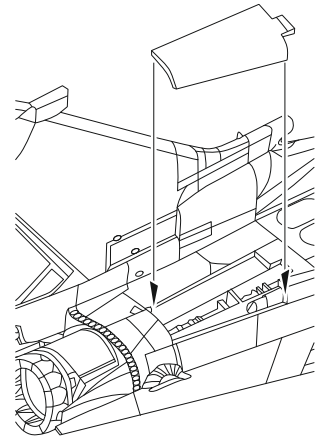

?

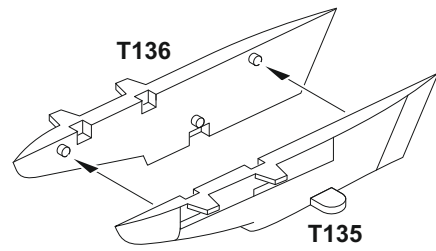
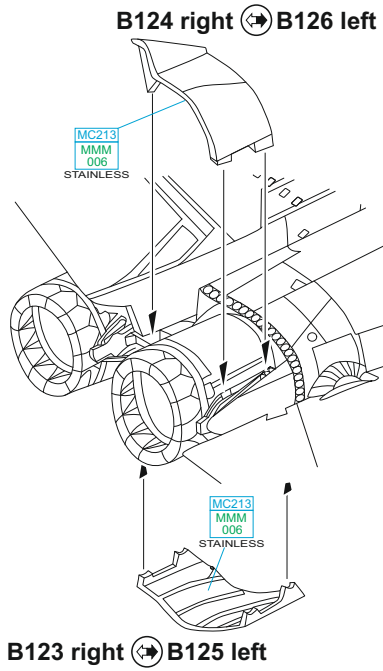
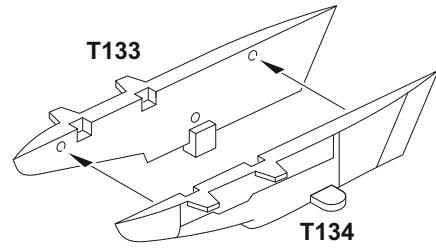
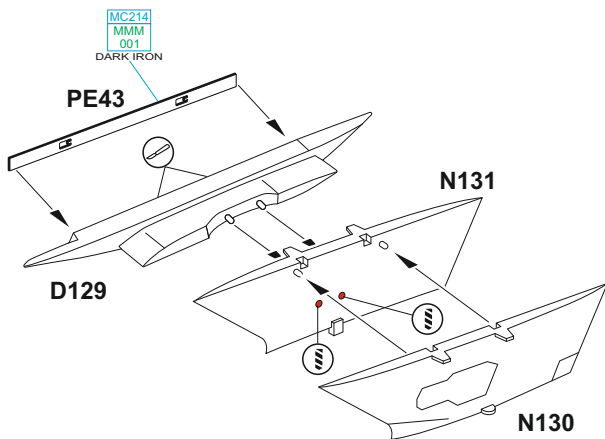
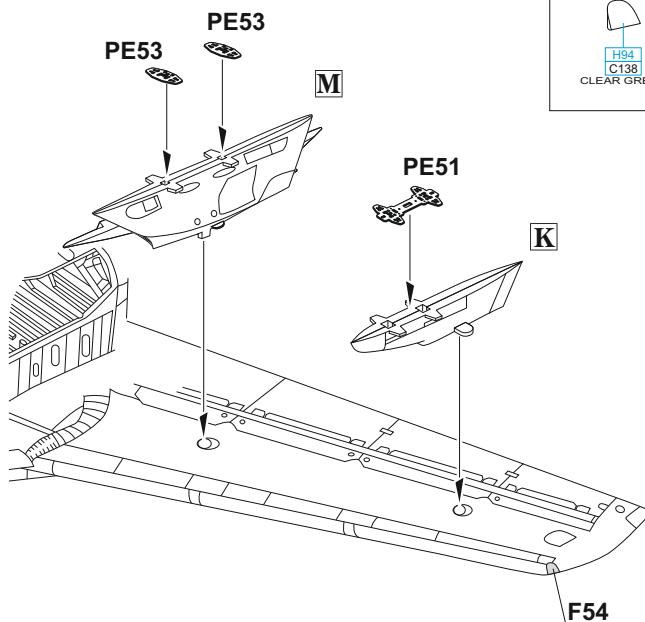
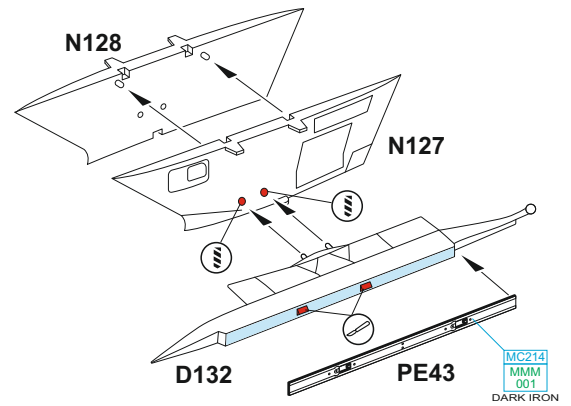
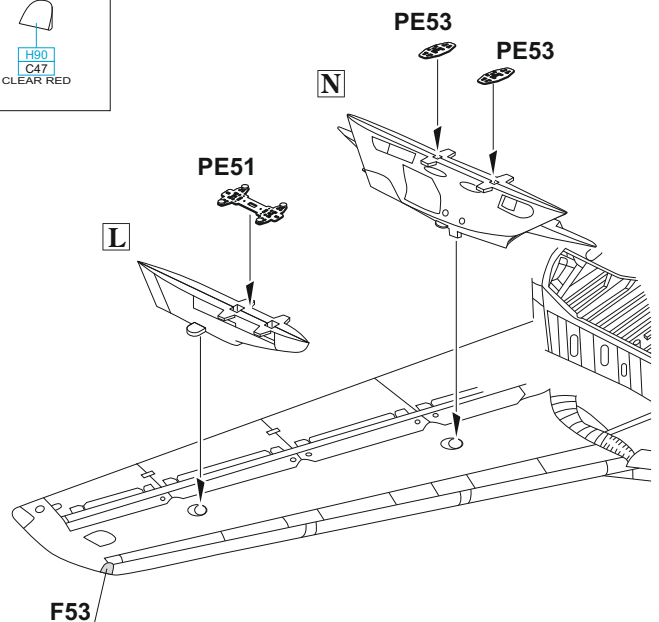
K**L****M****N****F54****F53**

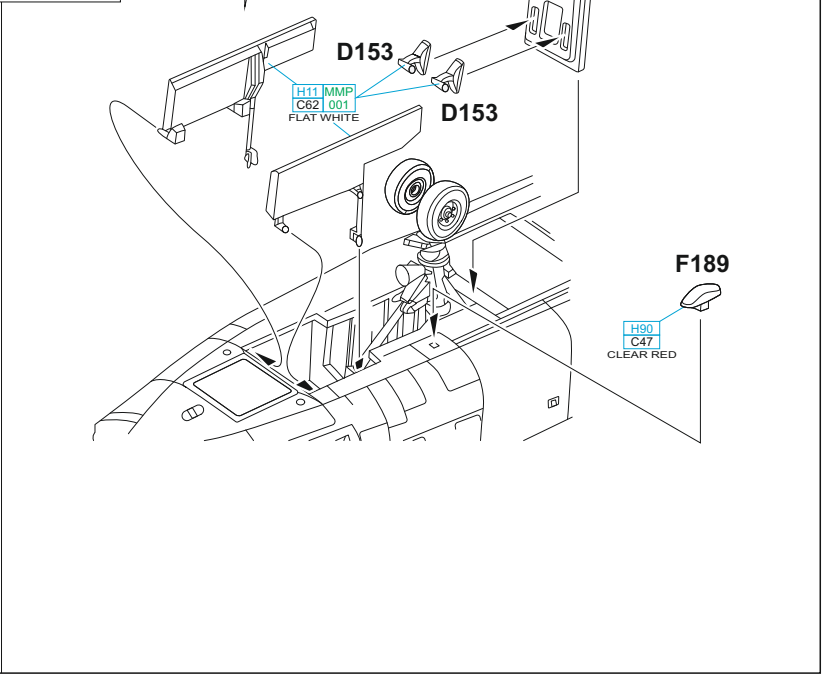
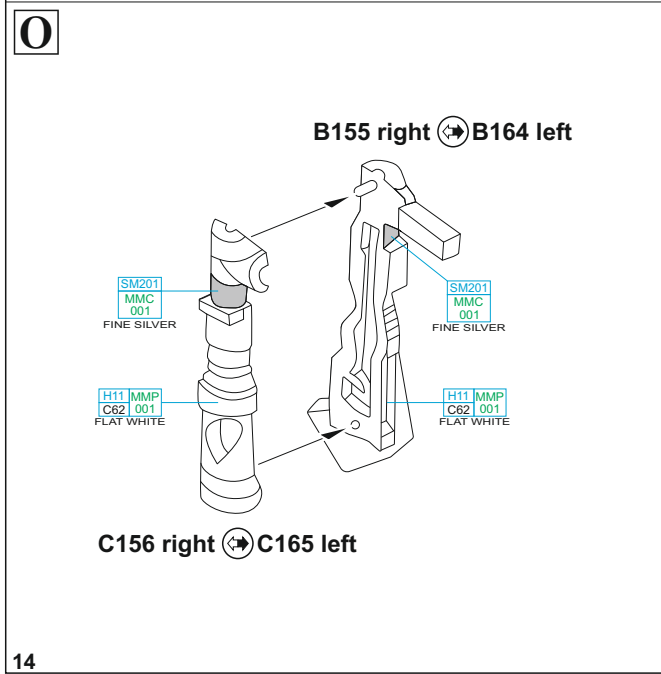
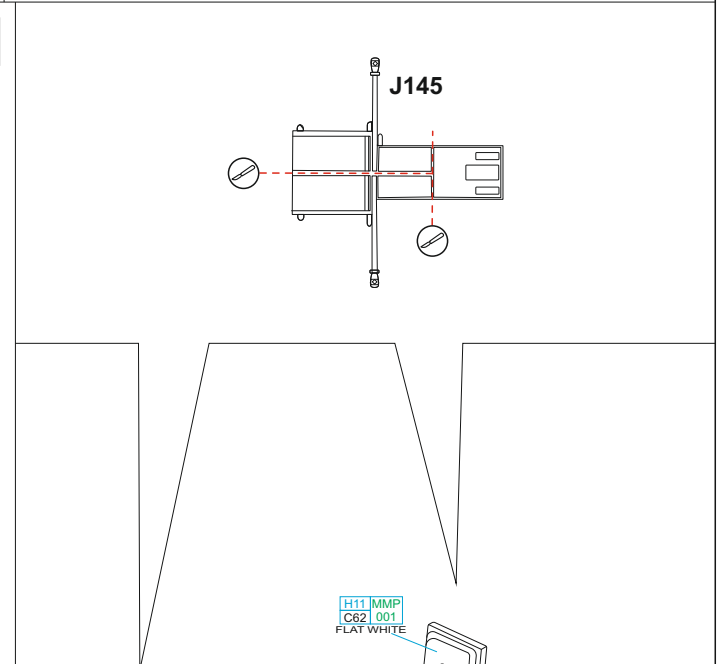
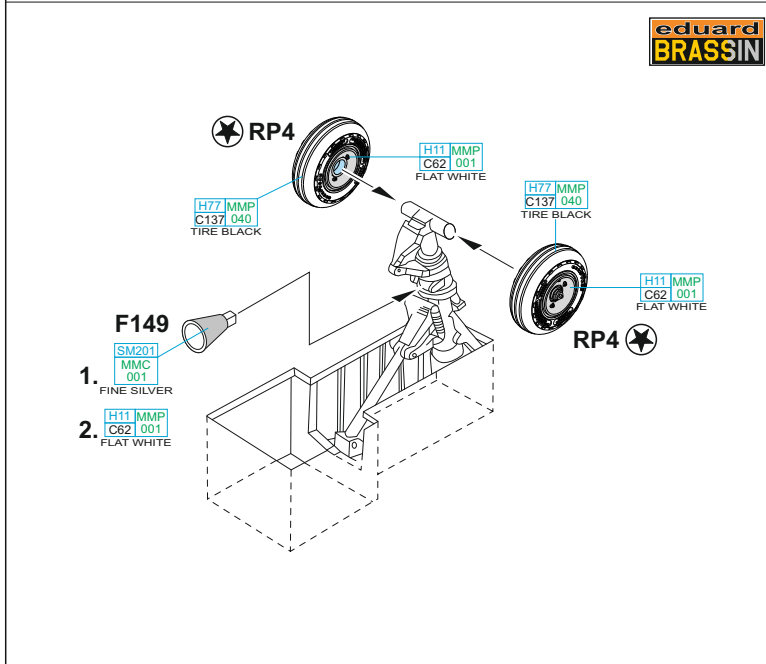
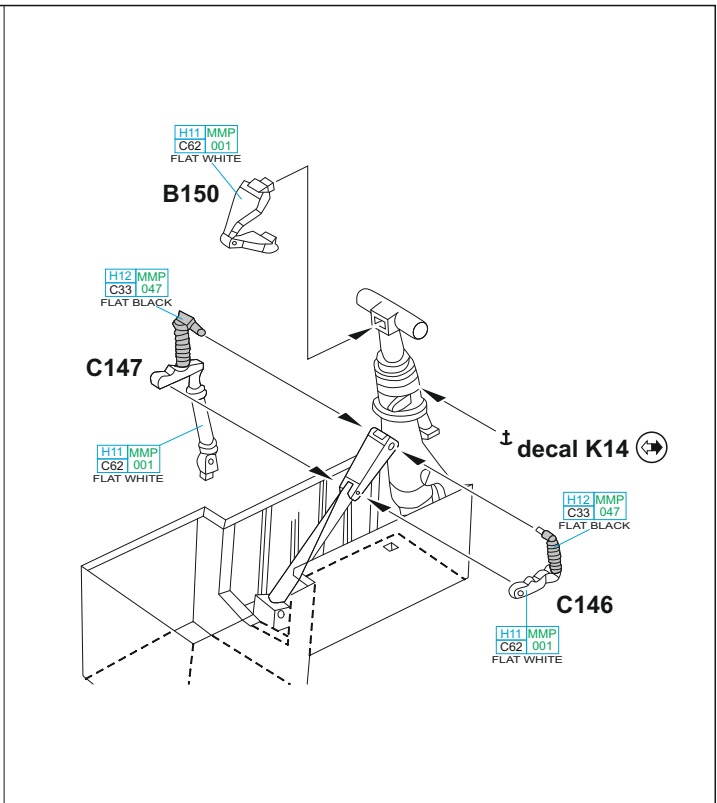
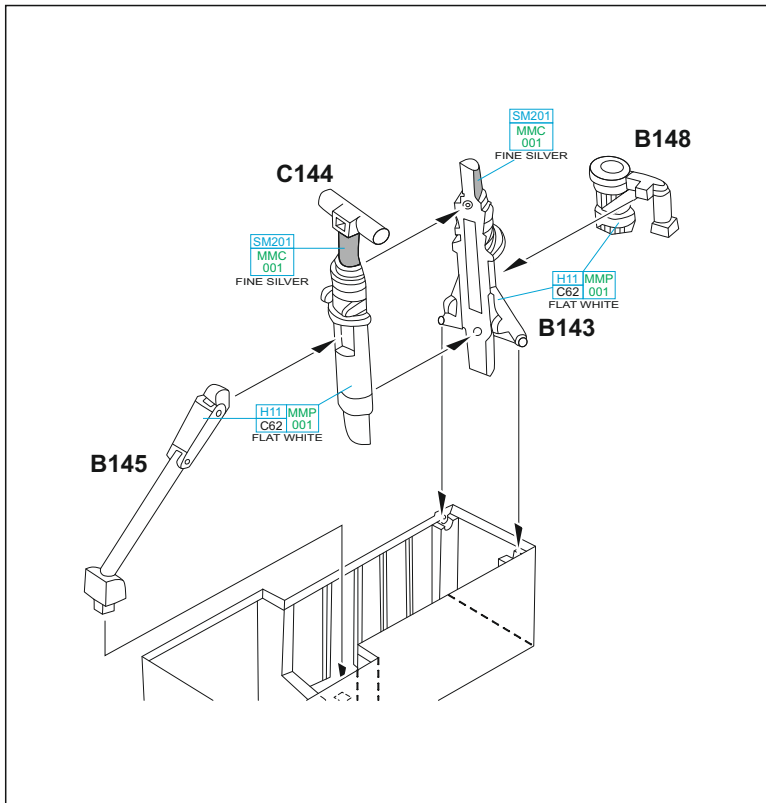

eduard
BRASSIN

O

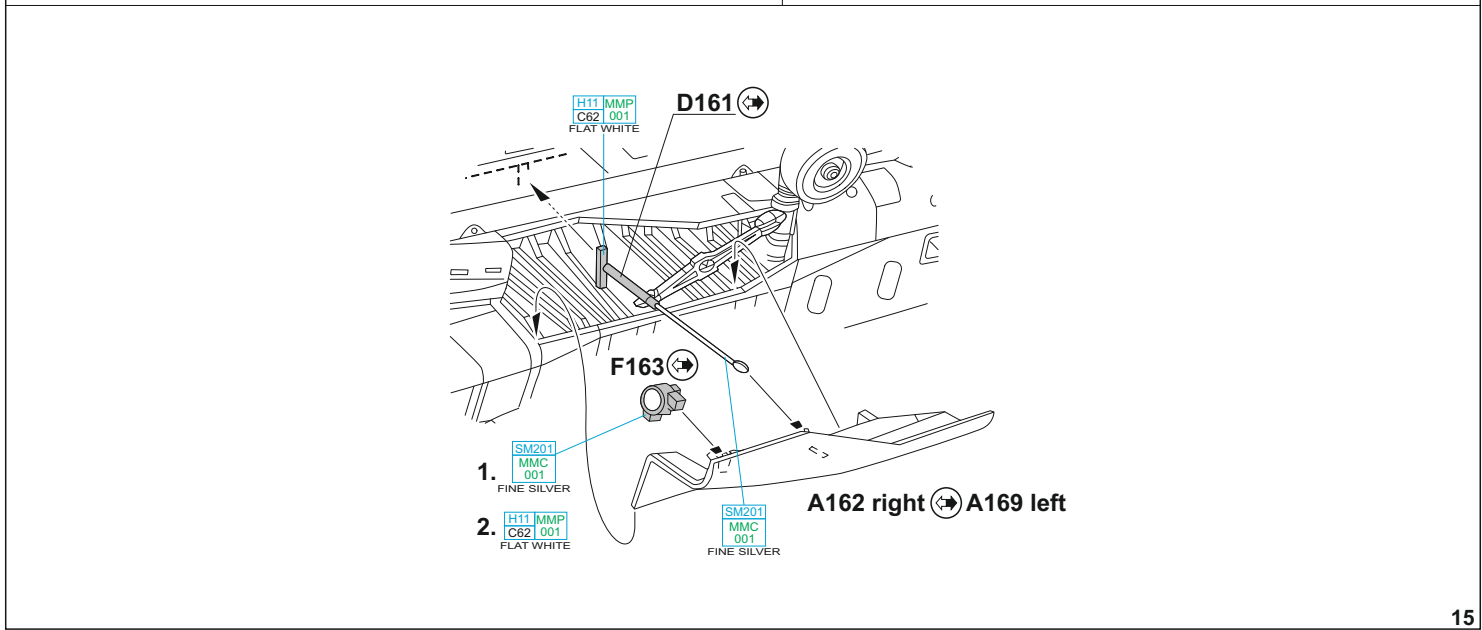
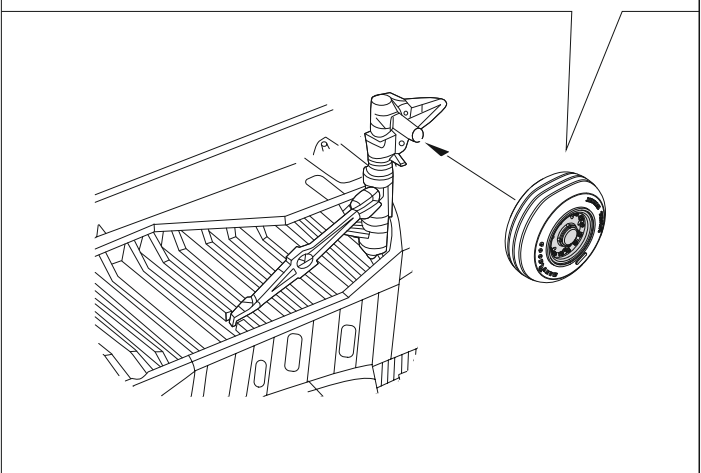
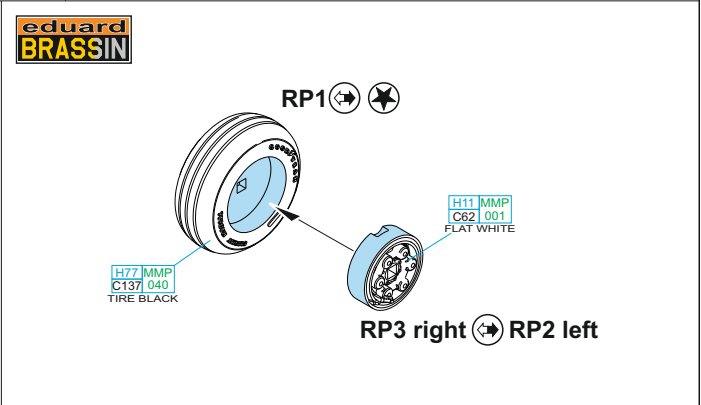
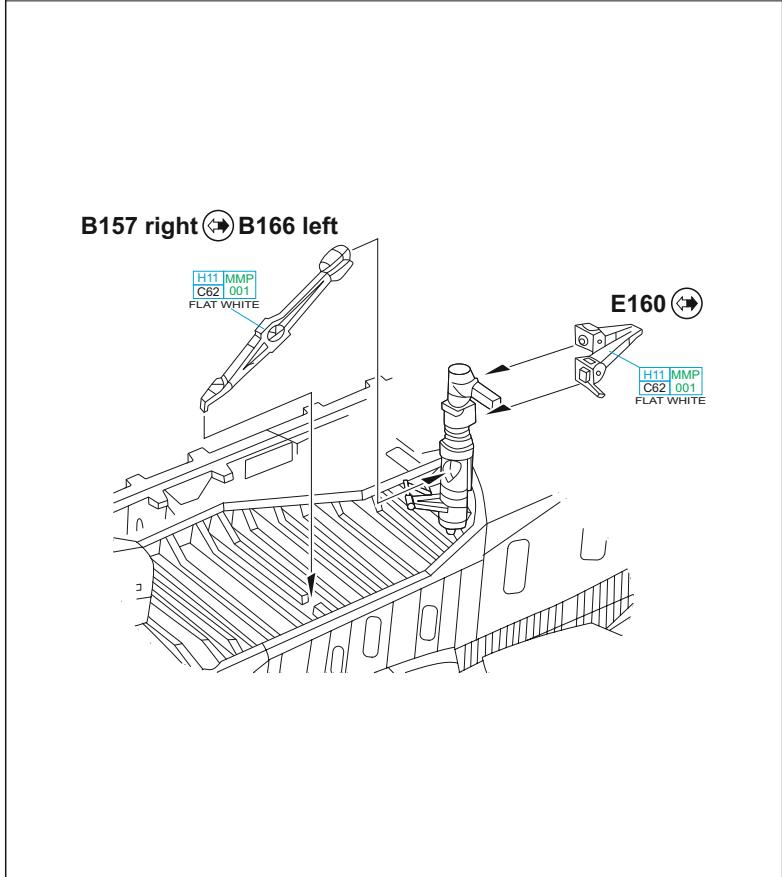
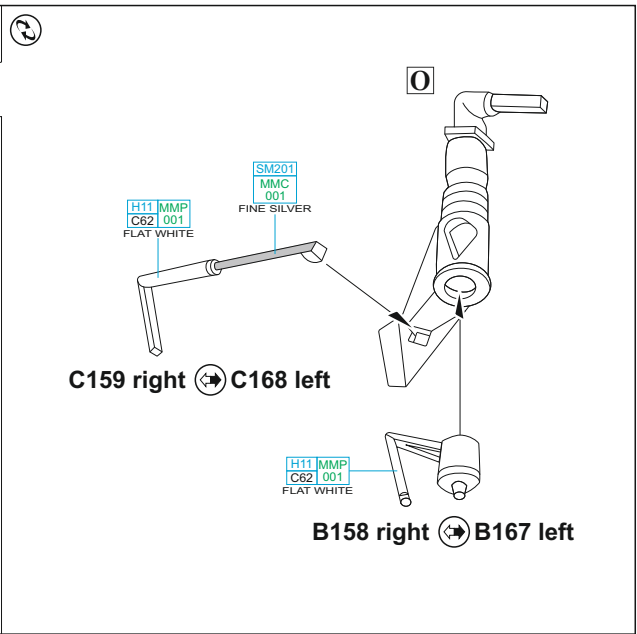
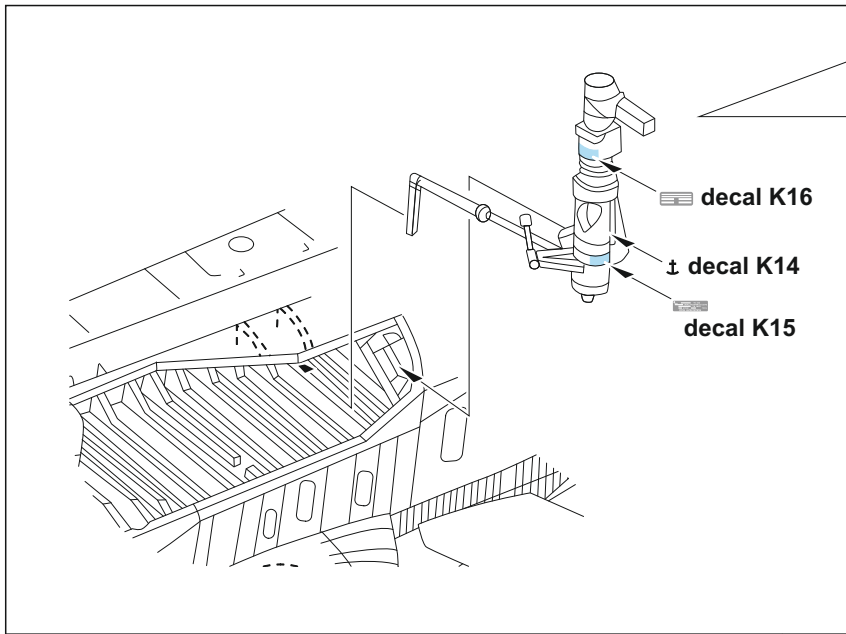

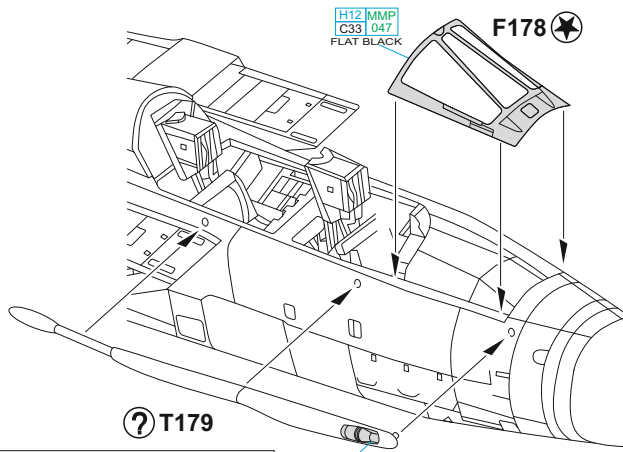

T179 - MARKINGS **A, C, D, F, G** ONLY

SM201
MMC
001
FINE SILVER

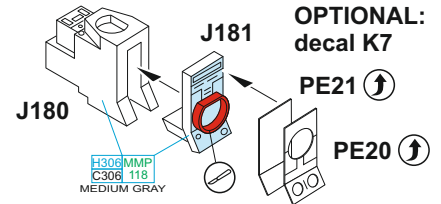

2 pcs.

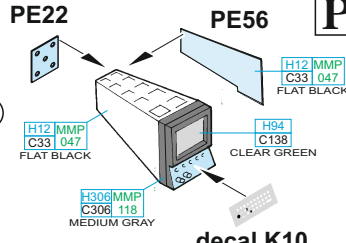
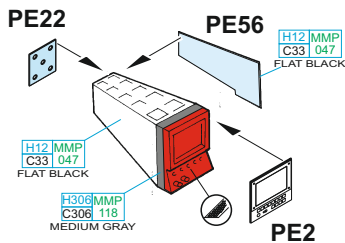
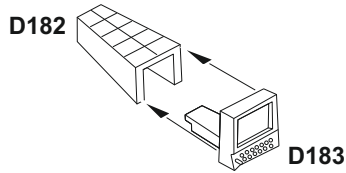

decal K10

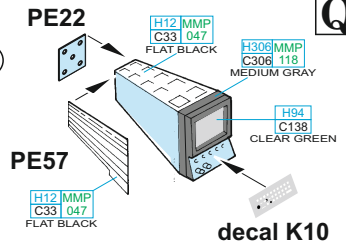
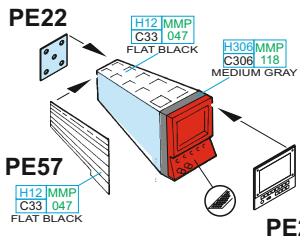

decal K10

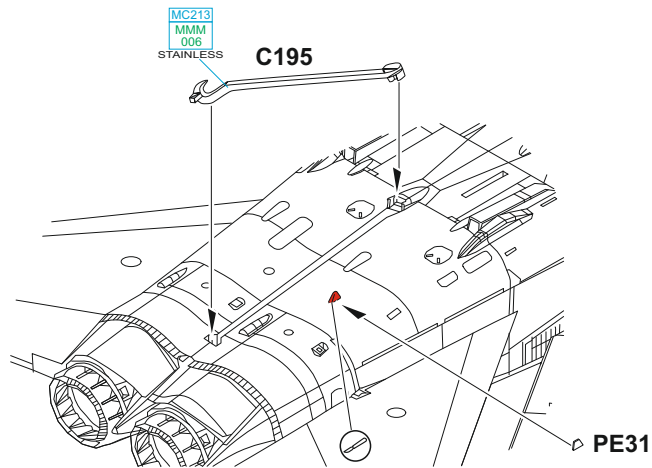
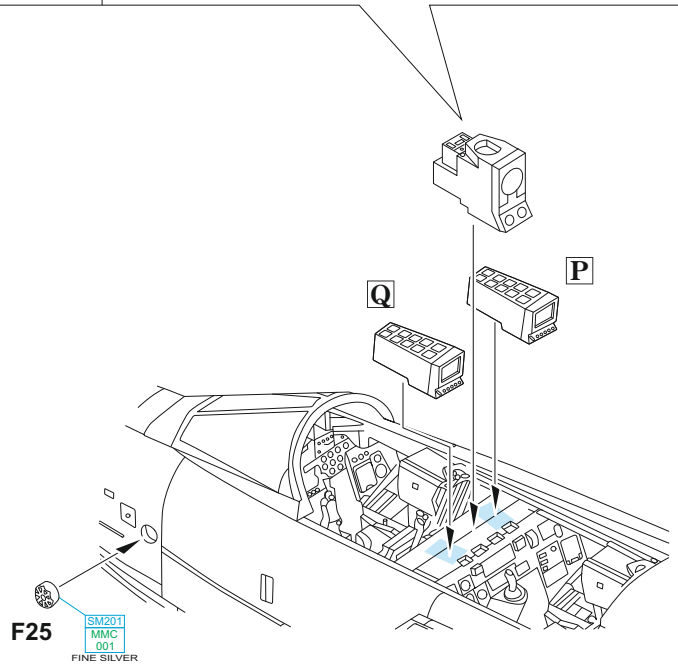

OPEN CANOPY

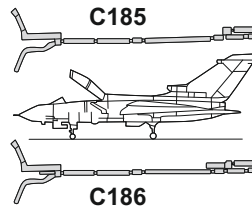

CLOSED CANOPY

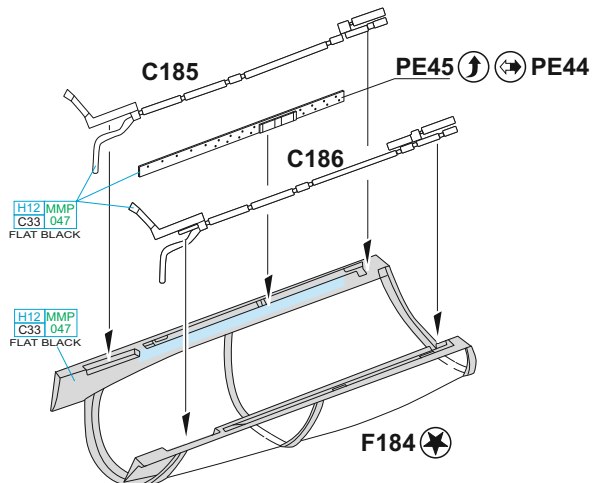
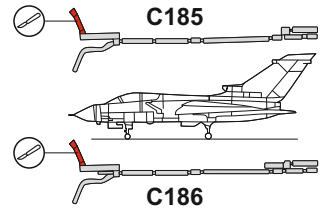

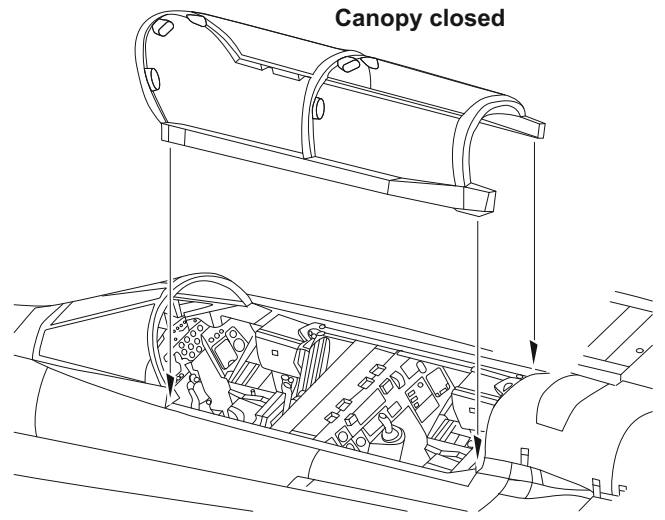
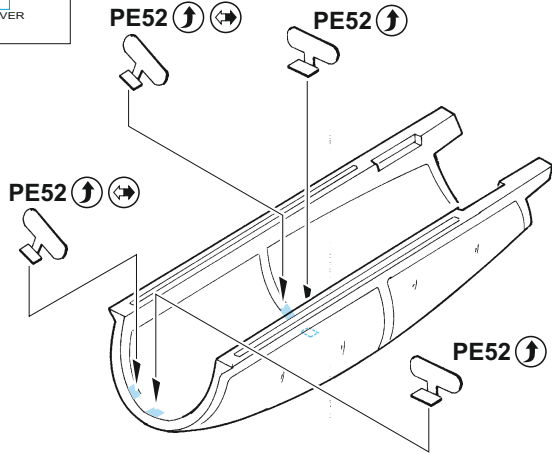
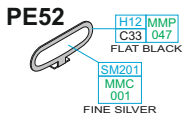

?

Canopy open

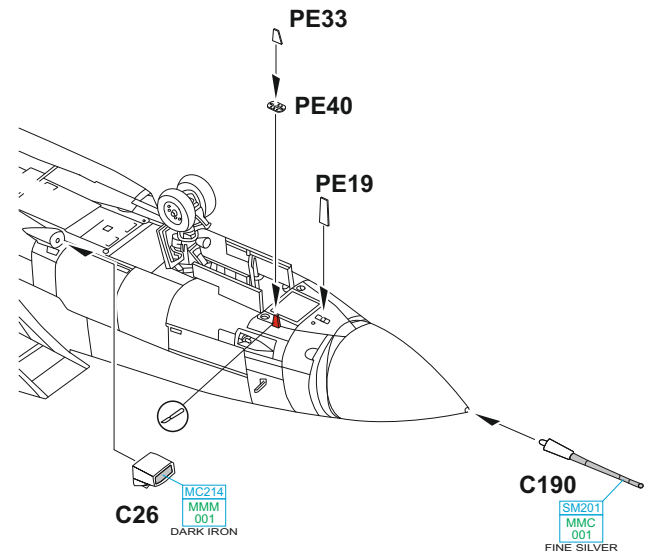
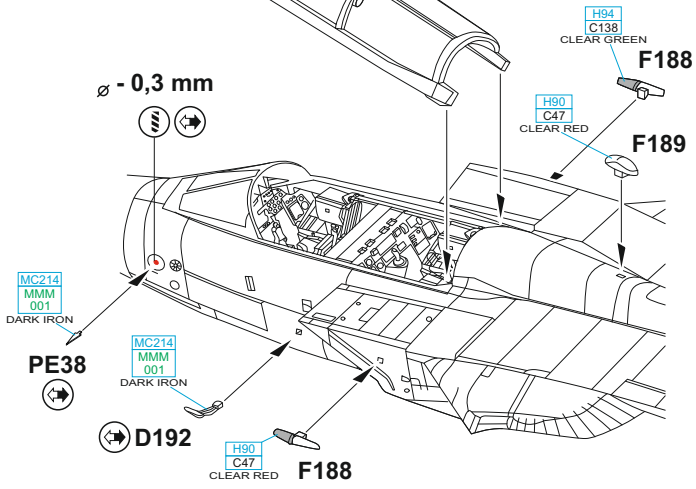

R ?

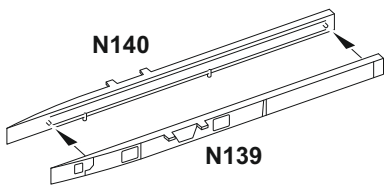

S

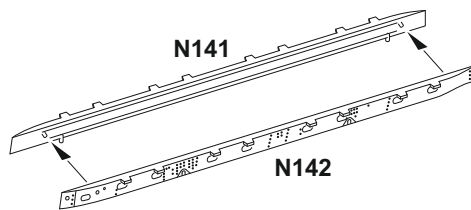

T

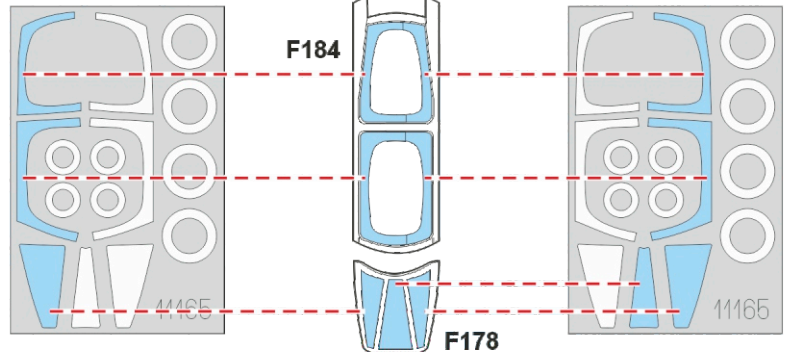
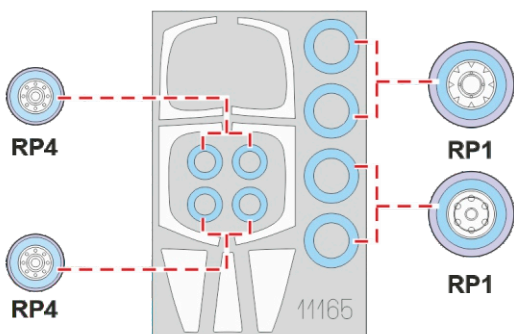
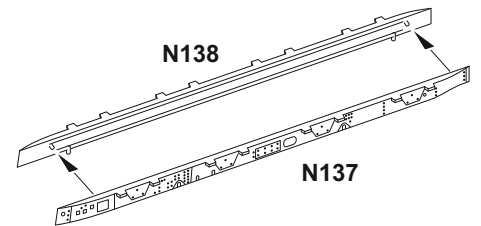

U ? 2 pcs.

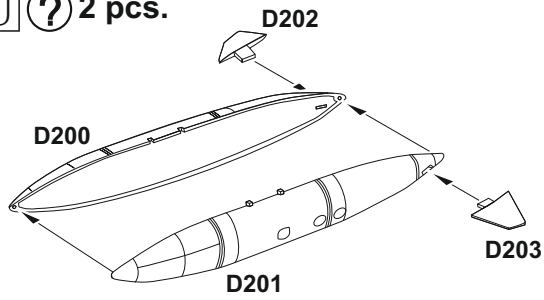

3 pcs
PE61

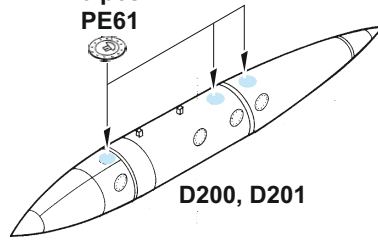

V MARKINGS **C, F** ONLY

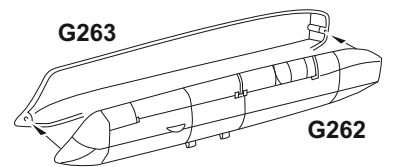

? MARKINGS **C, F** ONLY

V

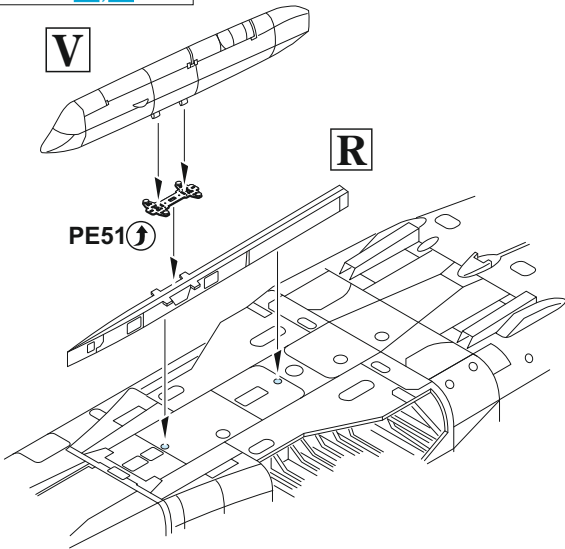

?

4 pcs.
PE51

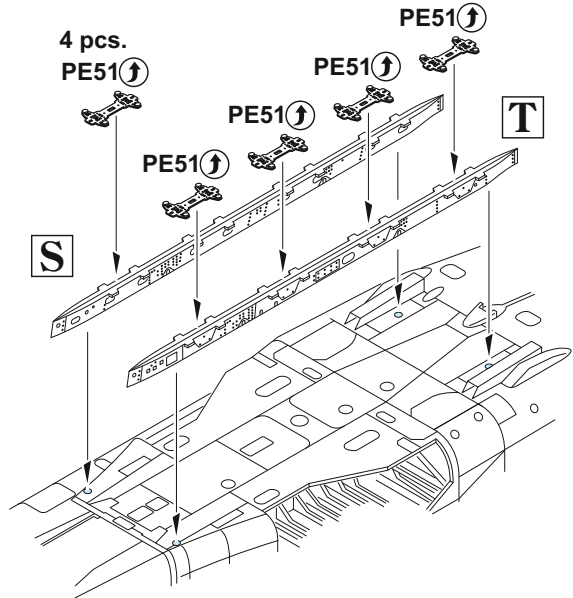

W ? 2 pcs.

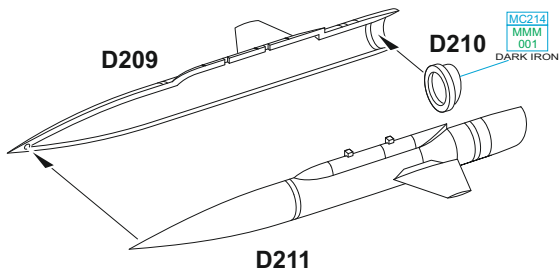

X ? MARKINGS **E, F** ONLY

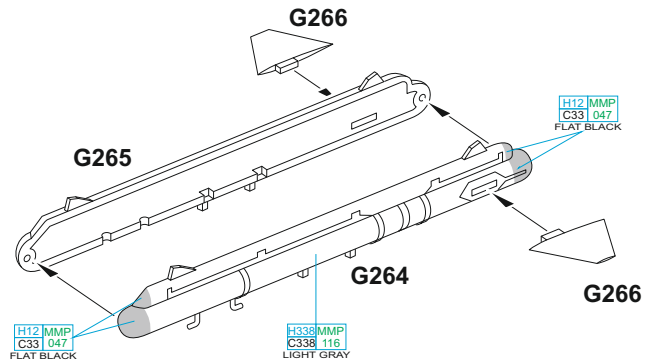

M **N**

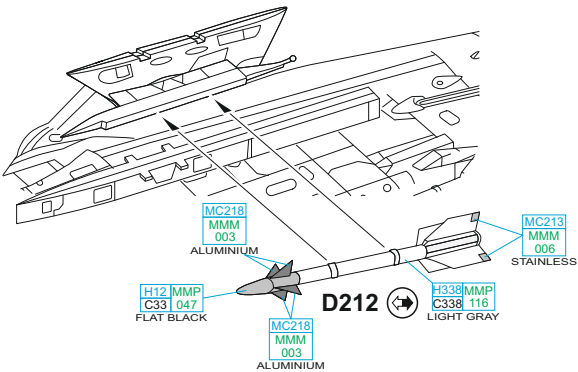

W

W ? **X**

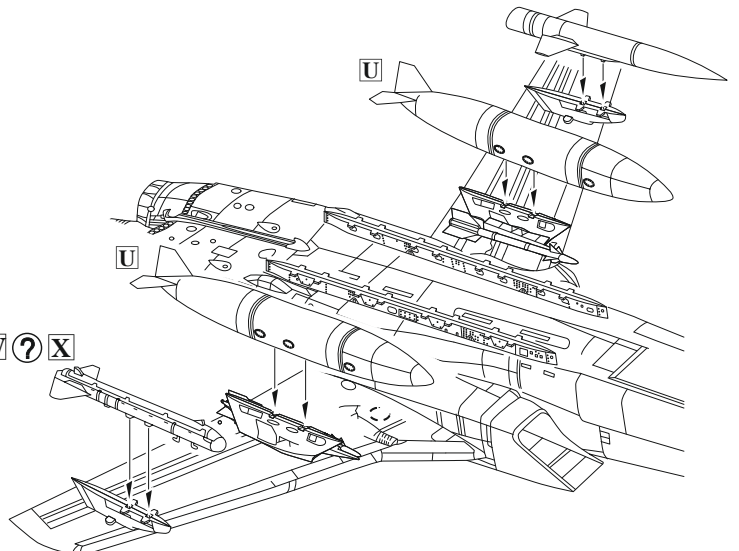

A MFG 2, Eggebek Air Base, Germany, 2002–2004

During 2002–2004 this colorfully painted Panavia Tornado IDS airplane coded 46+20 belonging to the Marinefliegergeschwader 2 was flown at the airshows. MFG 2 unit was as the last fighter wing of the German Navy disbanded in 2005. Under the MFG 2 marking on the vertical tail surface this Tornado 46+20 sports the insignia of the reactivated Aufklärungsgeschwader 51 (AG 51) "Immelmann" (51st Reconnaissance Wing). This unit was equipped with Tornados and took over part of the MFG 2 tasks. Tornado IDS 46+20 camouflage is painted according to the so-called Norm 87.



ČESKOU VERZI TEXTU NALEZNETE NA
www.eduard.com
 POD KATALOGOVÝM ČÍSLEM 11165



NAVY BLUE	H54 MMP C365 065	GREEN	H309MMP C309 031	DARK GRAY	H68 MMP C36 049	CLEAR RED	H90 MMP C47 167
FLAT BLACK	H12 MMP C33 108	CLEAR GREEN	H94 MMM C138 169	GRAY	H308MMP C308 073	CHROME SILVER	MC211 MMC 001
							BARLEY GRAY
							H334MMP C334 102

B JaBoG 38, Jever Air Base, Germany, 1986

The Jagdbombergeschwader 38 unit was based in the North, Lower Saxon's Jever. It was established in August 1983 and was armed with the multi-purpose Tornado IDS aircraft. In 1989 its 2. Staffel was equipped with Tornados ECR and flew them until 1995 when the ECR type Tornados were transferred to JaboG 32. On August 2005 the JaboG 38 was disbanded. The IDS Tornado coded 43+22 is camouflaged according to the so-called Norm 76.



ČESKOU VERZI TEXTU NALEZNETE NA
www.eduard.com
 POD KATALOGOVÝM ČÍSLEM 11165



OLIVE DRAB	H52 MMP C12 091	DARK GRAY	H68 MMP C36 049	BARLEY GRAY	H334 MMP C334 102	CLEAR RED	H90 MMP C47 167	RED	H3 MMP C3 003
FLAT BLACK	H12 MMP C33 108	GRAY	H305 MMP C305 084	GRAY	H53 C13	CLEAR GREEN	H94 MMM C138 169	CHROME SILVER	MC211 MMC 001
								GRAY	H308 MMP C308 073

C AG 51 "Immelmann", Schleswig-Jagel Air Base, Germany, 2002-2003

Aufklärungsgeschwader 51, the predecessor of the TaktLwG 51, was reactivated in January 1994. Previous AG 51, together with its sister unit AG 52 (both were equipped with the reconnaissance RF-4E), were disbanded in the middle of 1993. Newly established AG 51 received Tornados IDS supplemented with ECR version. Camouflage of the Tornado coded 43+46 was sprayed according to the so-called Norm 95 in three shades of grey and due to its participation in the NATO Tiger Meet 2002, taking place at the Portuguese airbase Beja (Base Aerea no.11/Base Aerea de Beja) the tiger stripes were added.



ČESKOU VERZI TEXTU NALEZNETE NA
www.eduard.com
 POD KATALOGOVÝM ČÍSLEM 11165



NAVY BLUE	H54 MMP C365 065	GREEN	H309MMP C309 031	DARK GRAY	H68 MMP C36 049	CLEAR RED	H90 MMP C47 167	BARLEY GRAY	H334MMP C334 102
FLAT BLACK	H12 MMP C33 108	BLACK	H2 MMP C2 047	WHITE	H11 MMP C62 001	CLEAR GREEN	H94 MMM C138 169	GRAY	H308MMP C308 073
								CHROME SILVER	MC211 MMC 001

D MFG 1, Schleswig-Jagel airbase, Germany, 1993

Marinefliegergeschwader 1 (MFG 1) wing of the German Navy was operational from 1959 to 1993 and in 1981 was equipped with 57 new Tornado fighters. Until then they had flown the American Starfighters. After the end of Cold War and Germany unification it was decided to reduce the number of the Bundeswehr units. MFG 1 was one of the "victims" of this developments and on December 31, 1993 was disbanded. The second MFG 1 flight was incorporated into the MFG 2. Tornado IDS 43+87 camouflage was painted according to the so-called Norm 76.

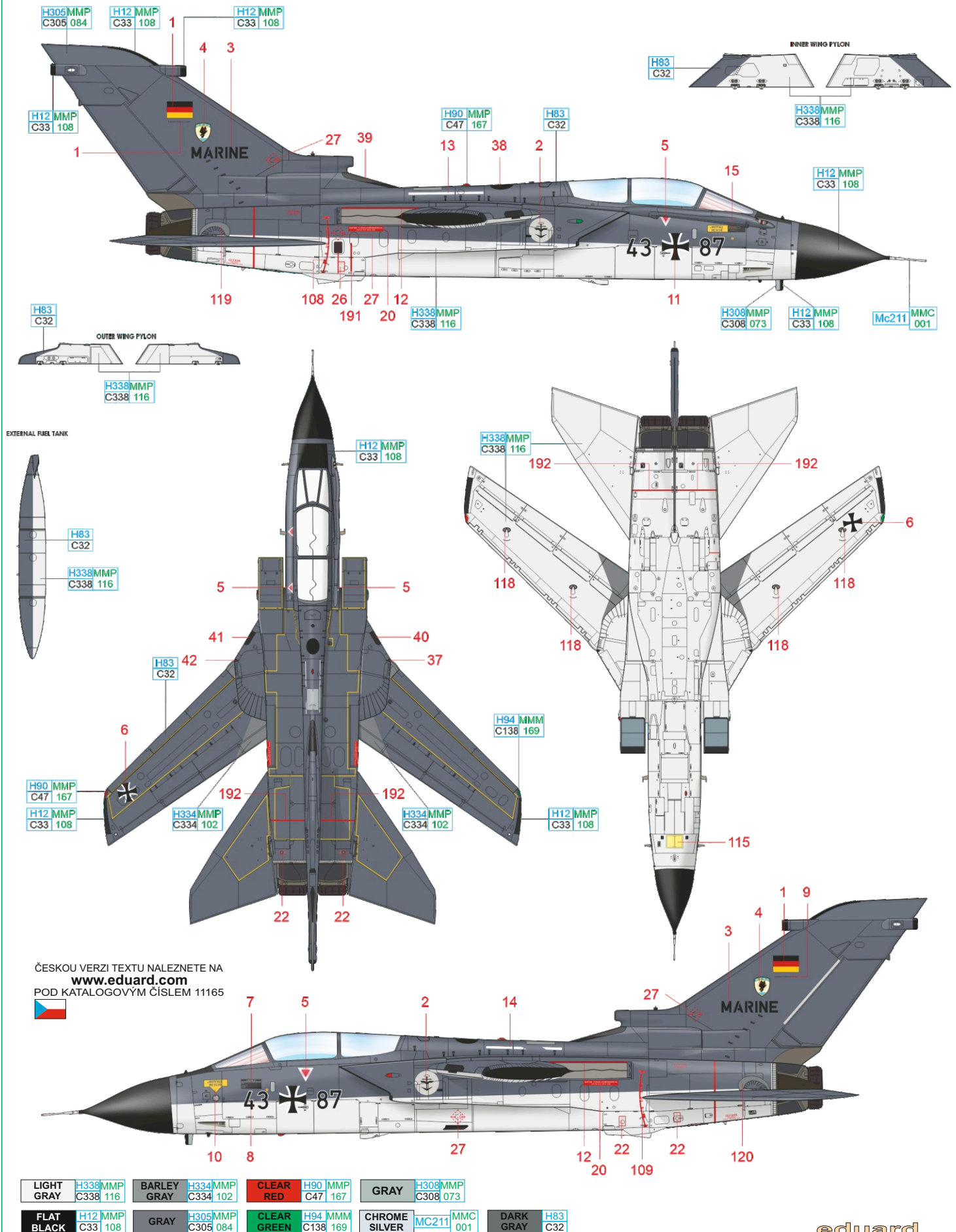

E JaBoG 31, Nörvenich Air Base, Germany, 2001–2002

Jagdbombergeschwader 31 (abbreviated as JaBoG 31) is the fighter-bomber wing based at Nörvenich in Western Germany. The unit was established in 1957 at Büchel airbase because Nörvenich base was not yet prepared to operate the new jet airplanes. On April 20, 1961 the squadron was named "Boelcke" in the honor of Oswald Boelcke, WWI Luftstreitkräfte fighter pilot. In 1979 the Jagdbombergeschwader 31 was the first Luftwaffe unit to be equipped with the new Panavia Tornado IDS aircraft. As a result of the German Air Force restructuring, on October 1, 2013 it was renamed to the Taktisches Luftwaffengeschwader 31 "Boelcke" (abbreviated as TaktLwG 32 "B"). On the same day the unit became the core unit of the newly established Tactical Air Force Group "Richthofen". In 2001 the Tornado coded 44+21 received the special color scheme commemorating 125.000 hours logged by the pilots of JaBoG 31 in Tornados.

44 ČESKOU VERZI TEXTU NALEZNETE NA www.eduard.com POD KATALOGOVÝM ČÍSLEM 11165

BARLEY GRAY	H334 MMP C334 102	GRAY	H308 MMP C308 073	CLEAR RED	H90 MMP C47 167
FLAT BLACK	H12 MMP C33 108	BLACK	H2 MMP C2 047	CLEAR GREEN	H94 MMM C138 169
				CHROME SILVER	MC211 MMC 001

F AG 51 "Immelmann", Schleswig-Jagel Air Base, Germany, 2006-2007

Predecessor of the TaktLwG 51, Aufklärungsgeschwader 51, was reactivated in January 1994. The previous AG 51, together with its sister unit AG 52 (both were equipped with reconnaissance RF-4E) was disbanded in the middle of 1993. Newly established AG 51 received Tornados IDS supplemented by ECR version. The tiger striping carried by 44+87 was presented for the first time at the NATO Tiger Meet in 2006 taking place at Albacete airbase in Spain. Tornado IDS 44+87 camouflage was painted according to the so-called Norm 95.

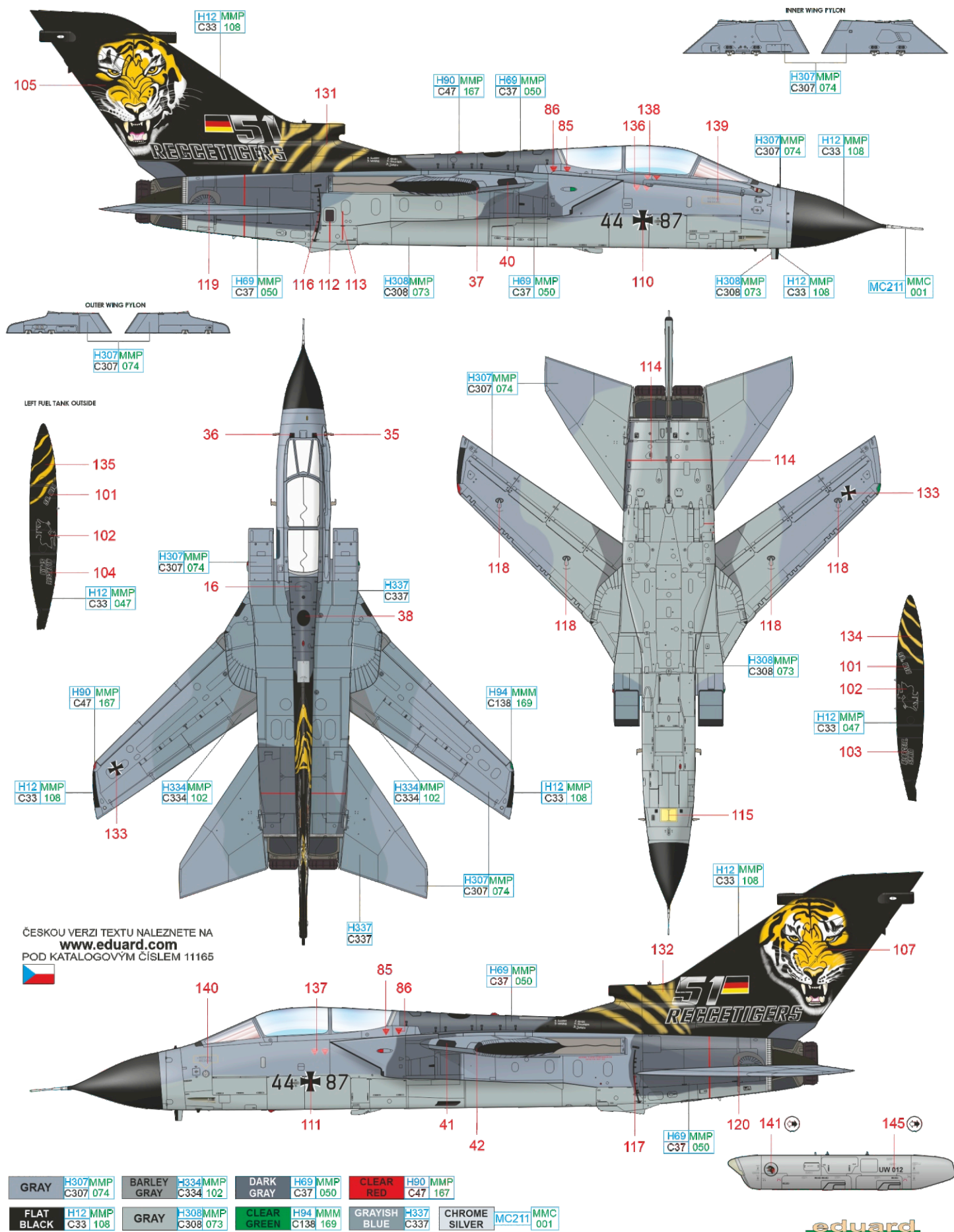

ČESKOU VERZI TEXTU NALEZNETE NA
www.eduard.com
 POD KATALOGOVÝM ČÍSLEM 11165



This unit was previously known as Jagdbombergeschwader 33. Due to the German Air Force restructuring, on October 1, 2013 the unit was renamed to the Taktisches Luftwaffengeschwader 33. It is based in the Western Germany at Büchel airbase and it is the only German AF unit able to carry the nuclear weapons. Tornado IDS 44+88 camouflage is painted according to the so-called Norm 83.

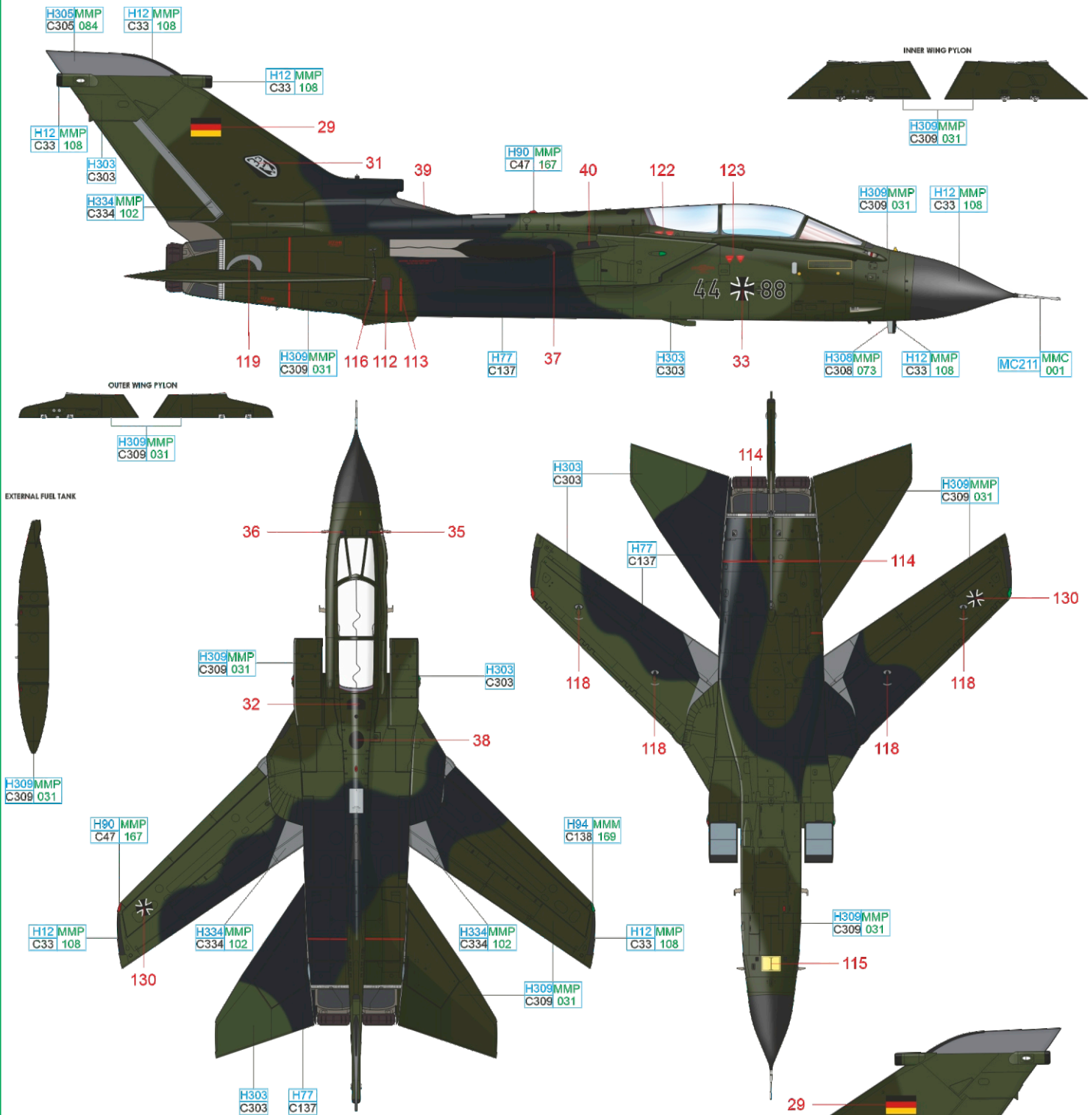

ČESKOU VERZI TEXTU NALEZNETE NA

www.eduard.com

POD KATALOGOVÝM ČÍSLEM 11165



GREEN	H309 MMP C309 031	OLIVE GREEN	H303 C303	GRAY	H305 MMP C305 084	CLEAR RED	H90 MMP C47 167	BARLEY GRAY	H334 MMP C334 102
FLAT BLACK	H12 MMP C33 108	TIRE BLACK	H77 C137	GRAY	H308 MMP C308 073	CLEAR GREEN	H94 MMM C138 169	CHROME SILVER	MC211 MMC 001

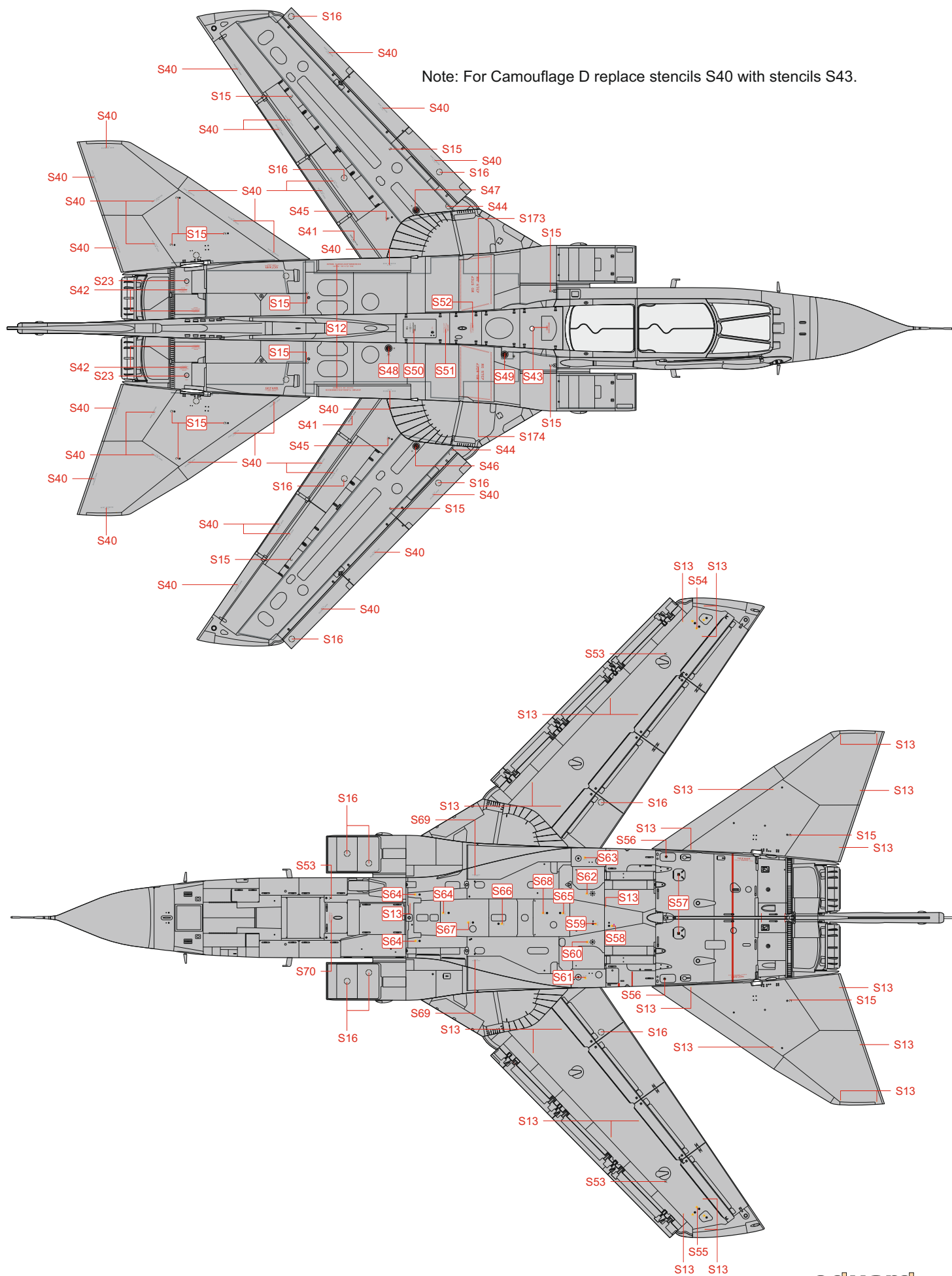

Auxiliary tank 1500l

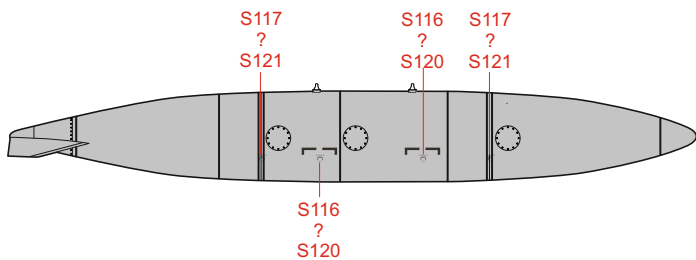
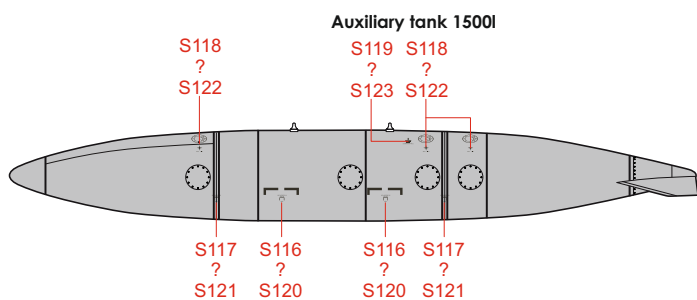

Bofors BOZ 101

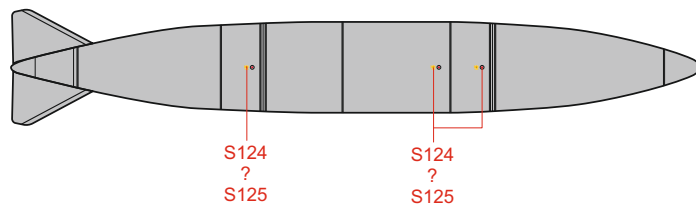
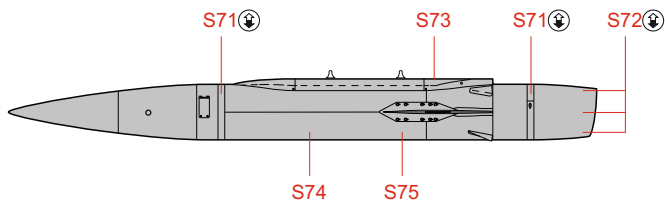

Cerberus III

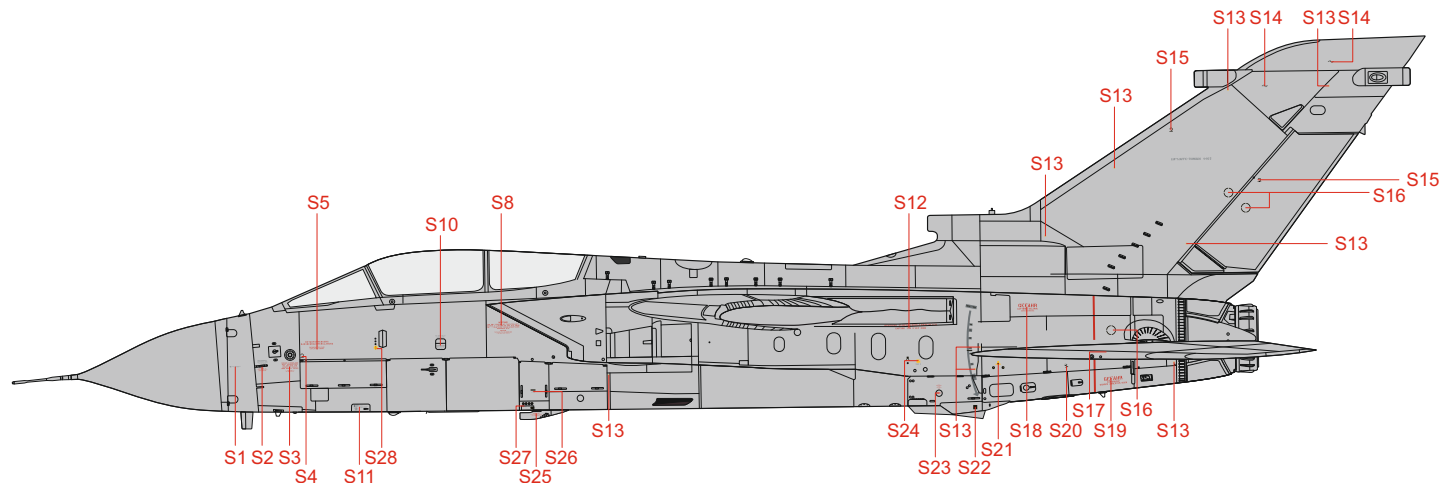
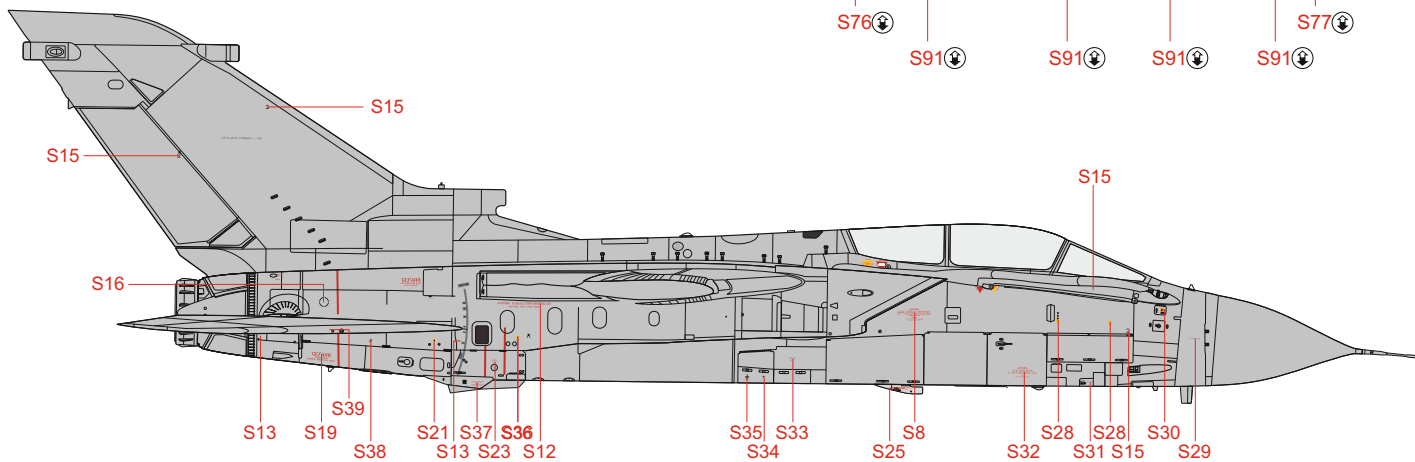
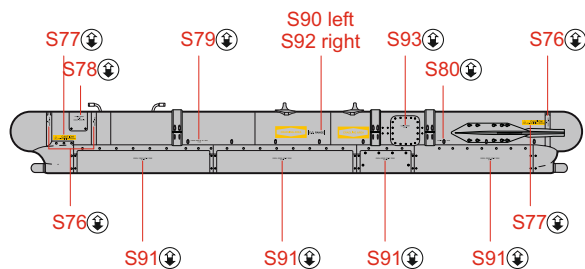

left outer pylon

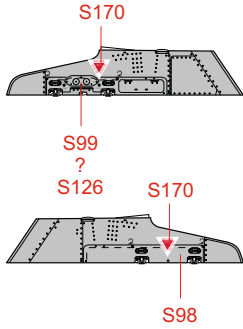

right outer pylon

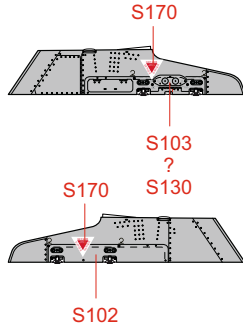

left inner pylon

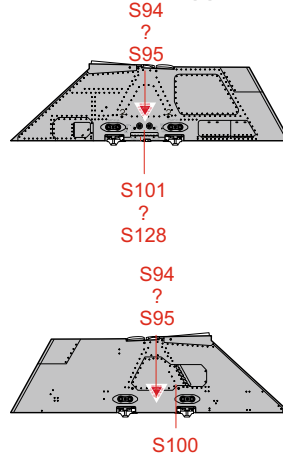

right inner pylon

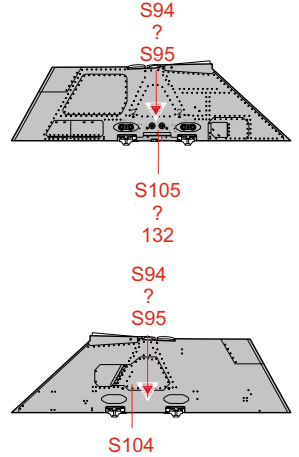

Right fuselage pylon

FWD →

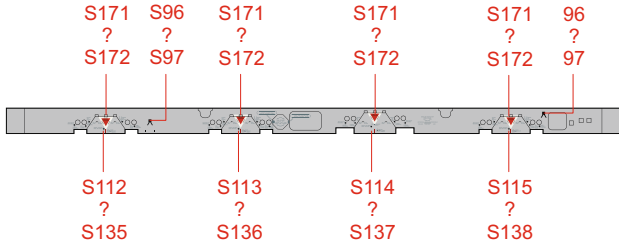

Center pylon - left

← FWD

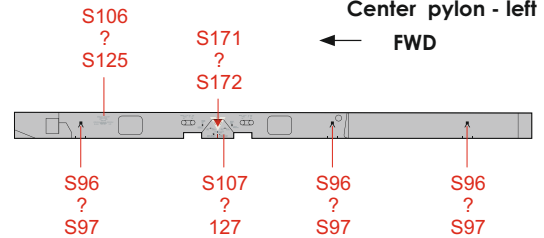

← FWD

Left fuselage pylon

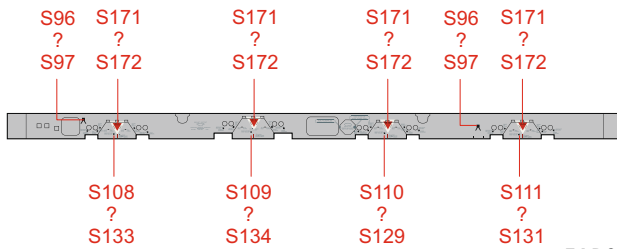

Center pylon - right

FWD →

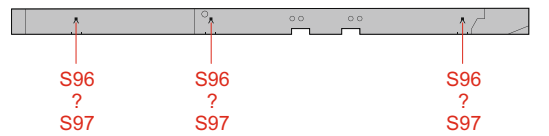

EADS RECCE Pod

