

eduard

LIMITED

1/48



Z-326 *Trenér Master*

INSTRUCTIONS SHEET

DUAL COMBO

11167-NAV1



Carefully read instruction sheet before assembling. When you use glue or paint, do not use near open flame and use in well ventilated room. Keep out of reach of small children. Children must not be allowed to suck any part, or pull vinyl bag over the head.



Před započítím stavby si pečlivě prostudujte stavební návod. Při používání barev a lepidel pracujte v dobře větrané místnosti. Lepidla ani barvy nepoužívejte v blízkosti otevřeného ohně. Model není určen malým dětem, mohlo by dojít k požití drobných dílů.

INSTRUCTION SIGNS * INSTR. SYMBOLS * INSTRUKTION SINNBILDEN * SYMBOLES * 記号の説明



OPTIONAL
VOLBA



BEND
OHNOUT



SAND
BROUSIT



OPEN HOLE
VYVRTAT OTVOR



SYMETRICAL ASSEMBLY
SYMETRICKÁ MONTÁŽ



REMOVE
ODŘÍZNOUT



REVERSE SIDE
OTOČIT



APPLY EDUARD MASK
AND PAINT
POUŽÍT EDUARD MASK
NABARVIT

PARTS



DÍLY



TEILE



PIÈCES



部品

PLASTIC PARTS

C>

2 pcs.

82180 C

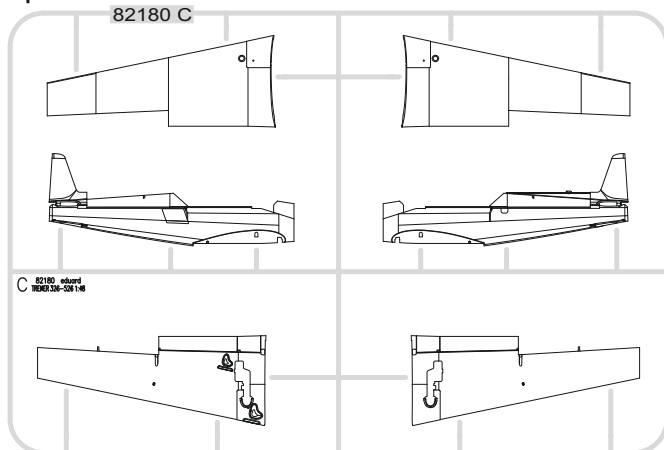

E>

2 pcs.

82180 E

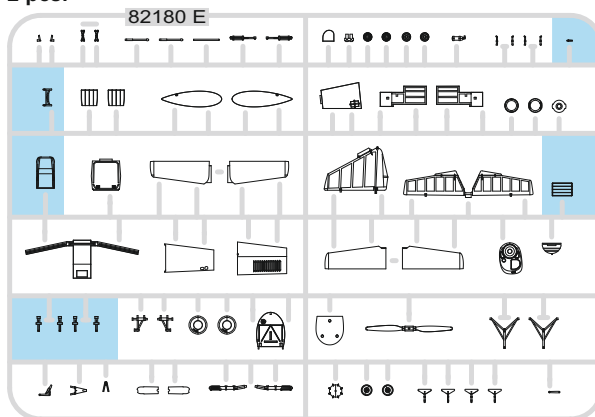

H>

2 pcs.

82180 H

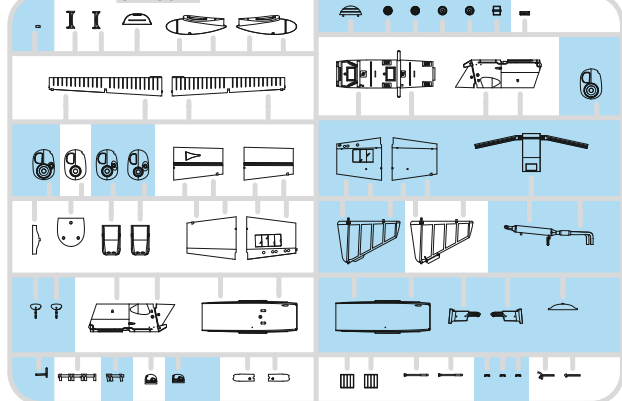

J>

2 pcs.

82180 J

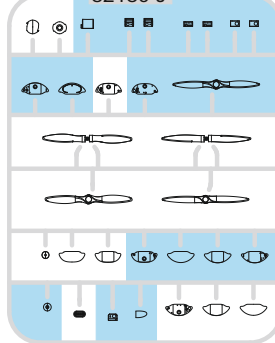

K>

2 pcs.

82180 K

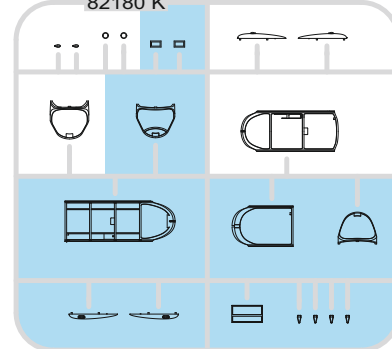
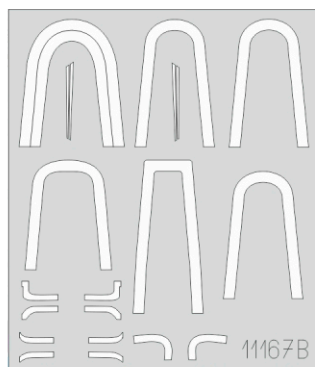
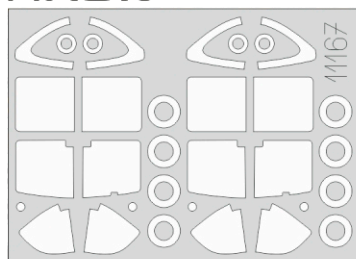
eduard
MASK

PE - PHOTO ETCHED DETAIL PARTS

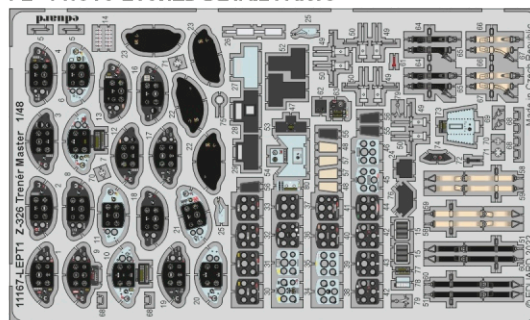



GSI Creos (GUNZE)		MISSION MODELS	
AQUEOUS	Mr.COLOR	PAINTS	
H1	C1	MMP-001	WHITE
H2	C2	MMP-047	BLACK
H3	C3	MMP-003	RED
H4	C4	MMP-007	YELLOW
H5	C5	MMP-048	BLUE
H7	C7	MMP-002	BROWN
H8	C8		SILVER
H12	C33	MMP-047	FLAT BLACK
H15	C65		BRIGHT BLUE
H18	C28		STEEL
H24	C58		ORANGE YELLOW
H25	C34		SKY BLUE
H35	C80		COBALT BLUE
H37	C43		WOOD BROWN
H39	C67		PURPLE
H77	C137	MMP-040	TIRE BLACK
H85	C45		SAIL COLOR
H90	C47		CLEAR RED
H94	C138		CLEAR GREEN
H301	C301	MMP-099	GRAY
H306	C306	MMP-118	MEDIUM GRAY

GSI Creos (GUNZE)		MISSION MODELS	
AQUEOUS	Mr.COLOR	PAINTS	
H308	C308	MMP-073	GRAY
H310	C310	MMP-060	BROWN
H320	C320	MMP-112	DARK GREEN
H413	C113	MMP-090	RLM04 YELLOW
H418	C118	MMP-055	RLM78 LIGHT BLUE
H422	C122	MMP-053	RLM82 LIGHT GREEN
	C19		SANDY BROWN
	C20		LIGHT BLUE
	C25		SEAGRAY
	C29	MMP-111	HULL RED
	C35		IJA GRAY
	C57		METALLIC BLUE GREEN
	C74		AIR SUPERIORITY BLUE
	C119		SAND YELLOW
	C159		SUPER SILVER
	C391		INTERIOR GREEN
Mr.METAL COLOR		METALLICS	
MC214		MMM-001	DARK IRON
MC215		MMM-004	COPPER
MC217			GOLD
MC218		MMM-003	ALUMINIUM

1 = - MARKINGS **A, C, D, E, G, H, I, J**
 - MARKINGS **B, F**

2 = - MARKINGS **A, B, C, D, E, F, G, I, J**
 - MARKING **H**

3 = 90% ALUMINIUM + 10% GOLD

4 = - MARKINGS **D, F**
 - MARKINGS **A, C, G, H, I, J**
 - MARKING **B**
 80% + 20% - MARKING **E**

5 = - MARKINGS **A, D, E, F, G, H**
 - MARKING **J**
 - MARKING **B**
 - MARKINGS **C, I**

6 = - MARKINGS **A, F, G, H, I**
 - MARKINGS **B, J**
 - MARKINGS **D, E**
 - MARKING **C**

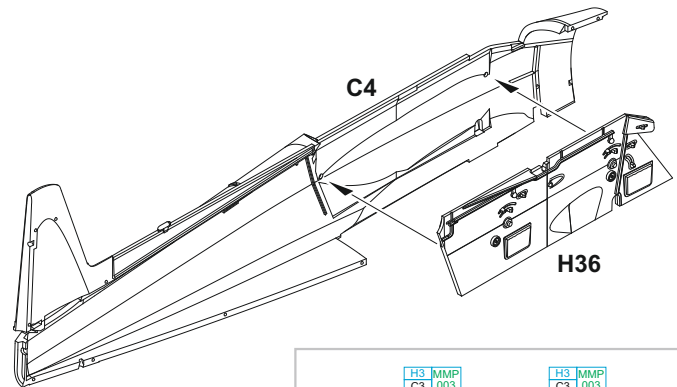
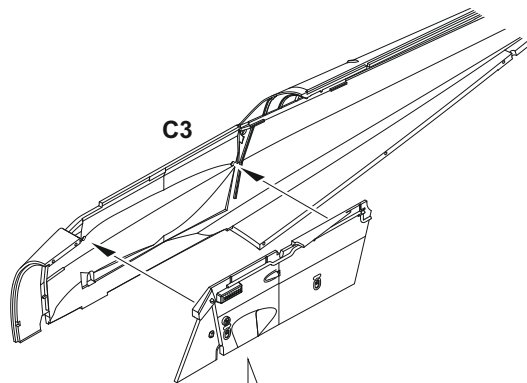

MARKINGS **A, C, D, E, G, H, I**

MARKINGS **B, F, J**

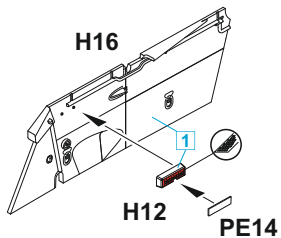

?

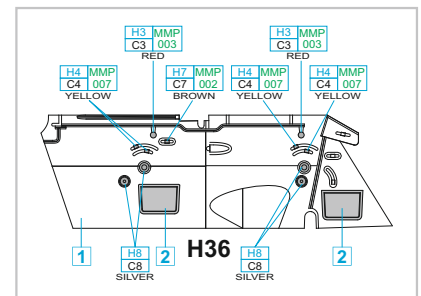
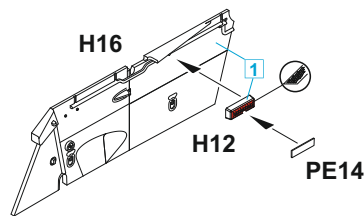

A MARKING **B**

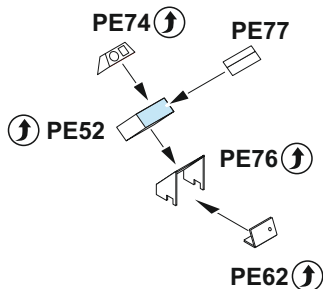

MARKING **F**

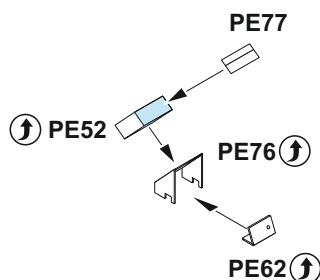

MARKING **G**

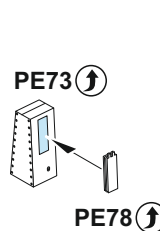

MARKING **J**

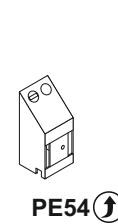

B

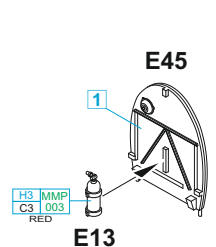

C

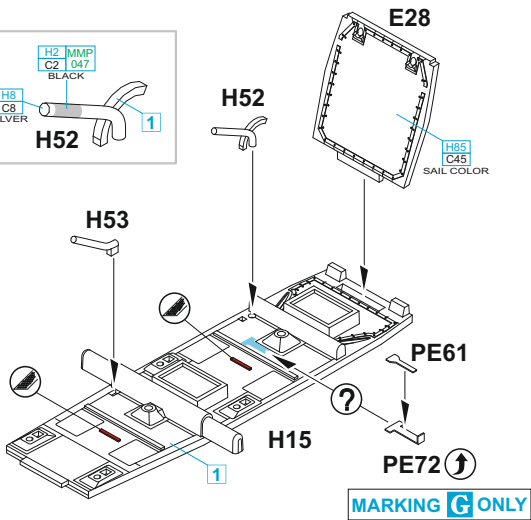
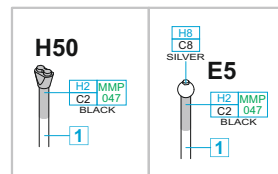
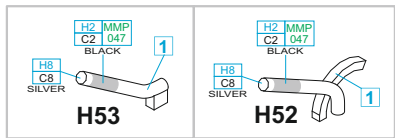

E5 - MARKINGS B, C, F, G, I
H50 - MARKINGS A, D, E, H, J

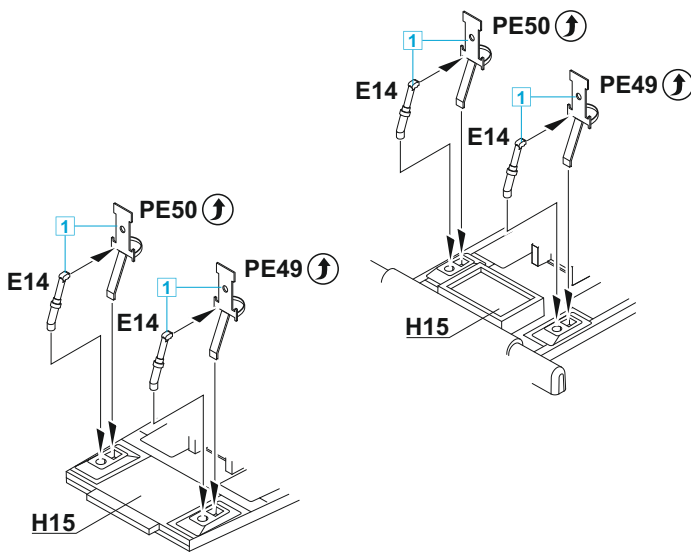
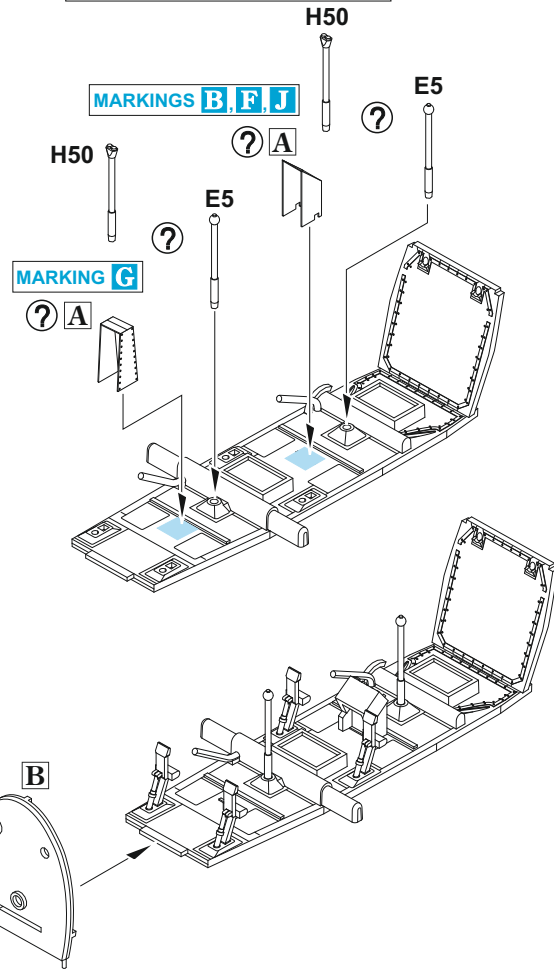

D

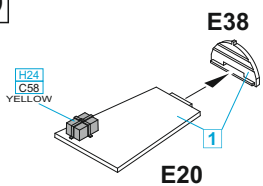

MARKINGS A, I ONLY

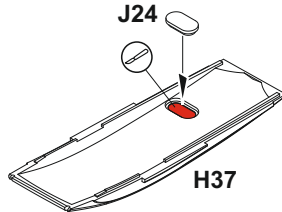

MARKINGS A, B, D, E, F, G, H, J

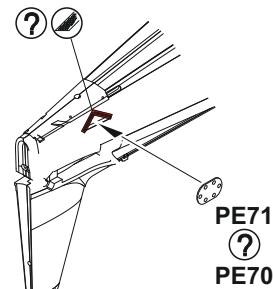

MARKINGS B, C, D, G, J ONLY

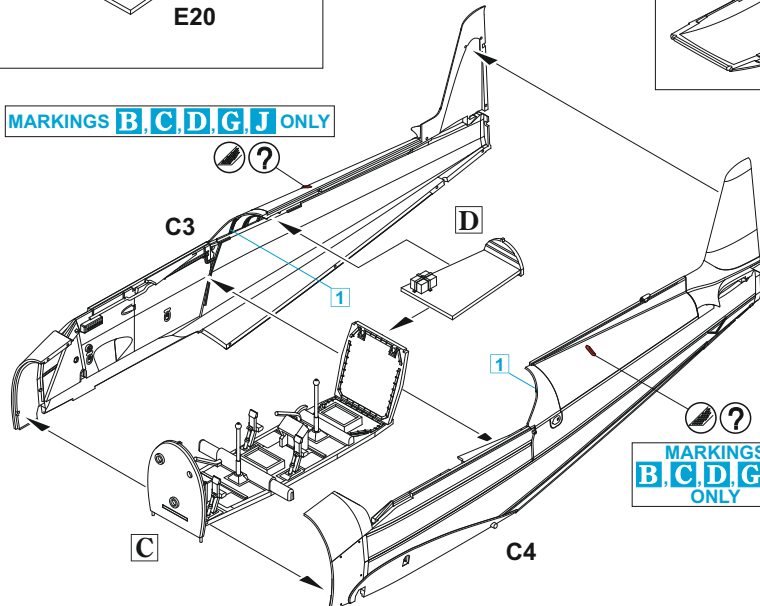

MARKINGS B, C, D, G, J ONLY

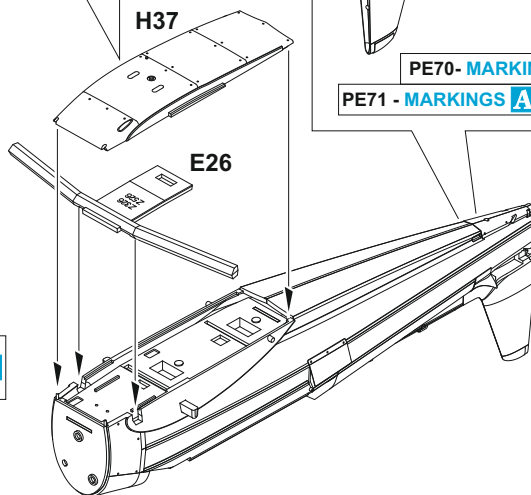

PE70 - MARKINGS B, H
PE71 - MARKINGS A, F, G, J

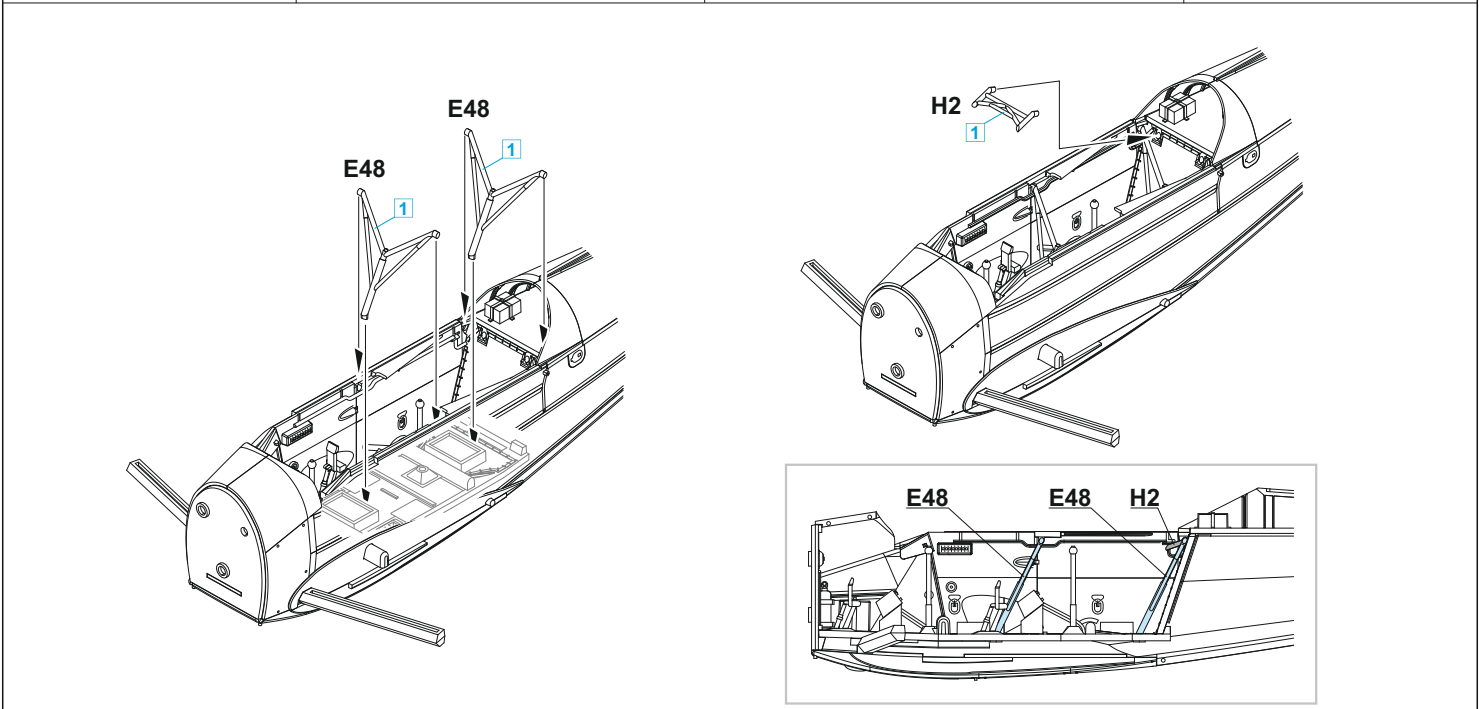
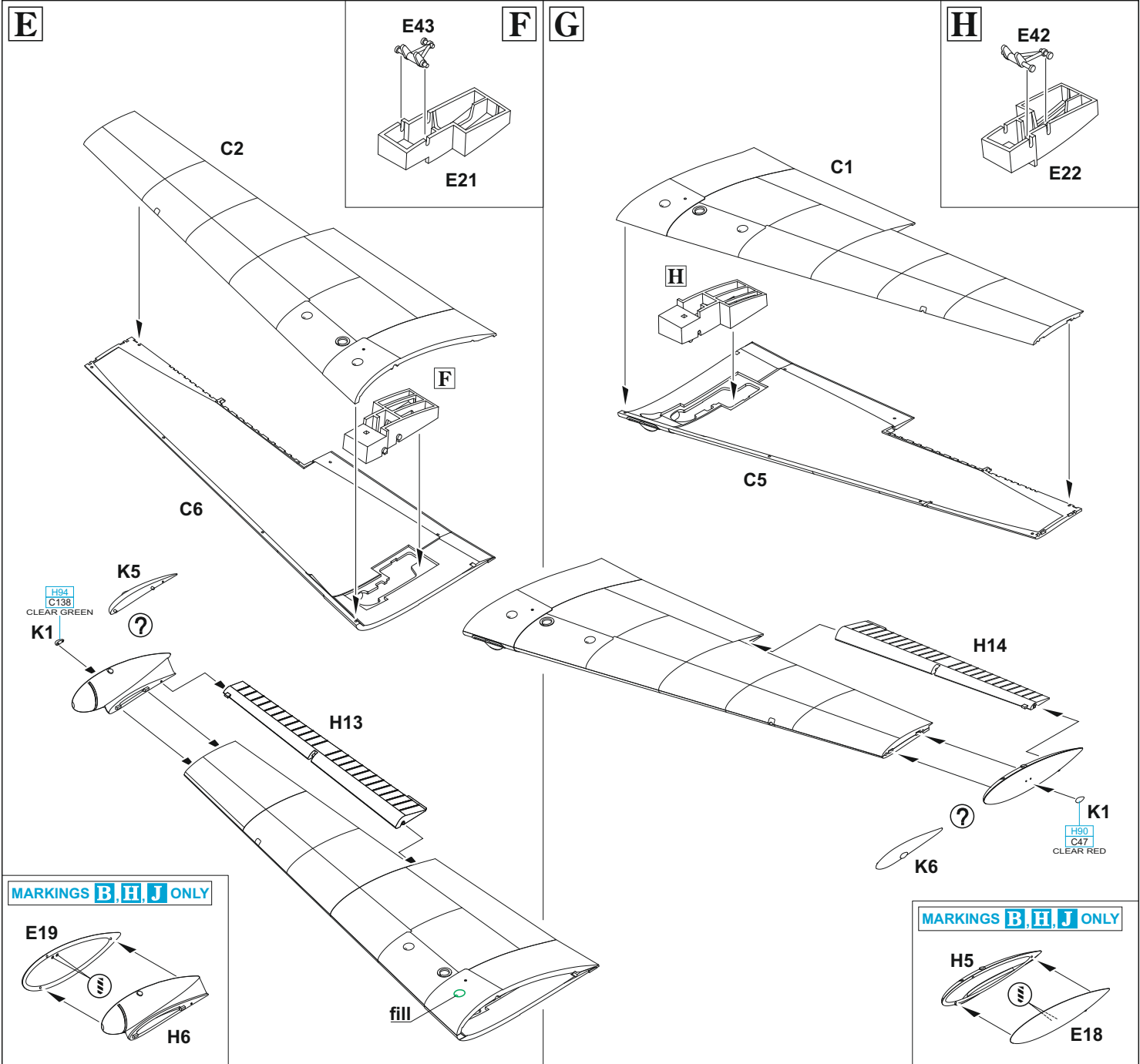

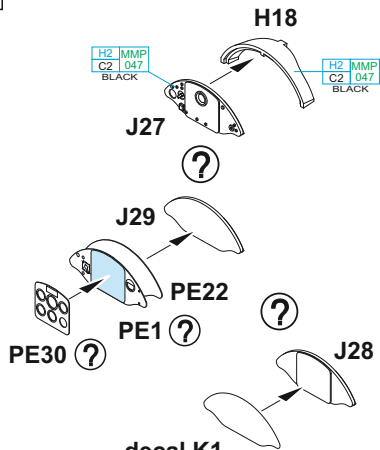
I

- PE1, 22, 30 - MARKING **A**
- PE3, 22, 32 - MARKING **B**
- PE9, 22, 36 - MARKING **C**
- PE7, 22, 34 - MARKING **D**
- PE10, 22, 38 - MARKING **E**
- PE12, 22, 40 - MARKING **F**
- PE19, 22, 42 - MARKING **G**
- PE17, 22, 42 - MARKING **H**
- PE17, 22, 42 - MARKING **I**
- PE20, 22, 45 - MARKING **J**

decal K1

BASE COLOR J28

- H12 MMP C33 047 FLAT BLACK - MARKINGS **A, B, C, F, G, H, I**
- H308 MMP C308 118 MEDIUM GRAY - MARKINGS **D, E, J**

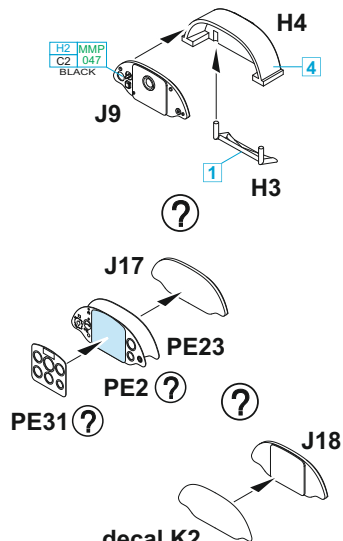
J

- PE2, 23, 31 - MARKING **A**
- PE4, 23, 33 - MARKING **B**
- PE8, 23, 37 - MARKING **C**
- PE6, 23, 35 - MARKING **D**
- PE11, 23, 39 - MARKING **E**
- PE13, 23, 41 - MARKING **F**
- PE18, 23, 43 - MARKING **G**
- PE16, 23, 43 - MARKING **H**
- PE16, 23, 44 - MARKING **I**
- PE21, 23, 46 - MARKING **J**

decal K2

BASE COLOR J18

- H12 MMP C33 047 FLAT BLACK - MARKINGS **A, B, C, F, G, H, I**
- H308 MMP C308 118 MEDIUM GRAY - MARKINGS **D, E, J**

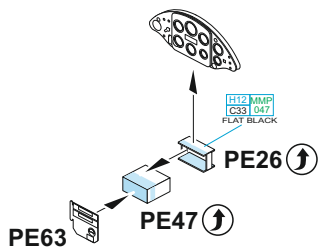
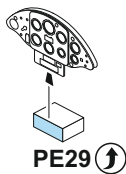
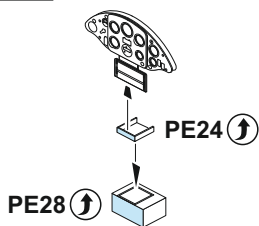
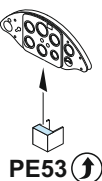
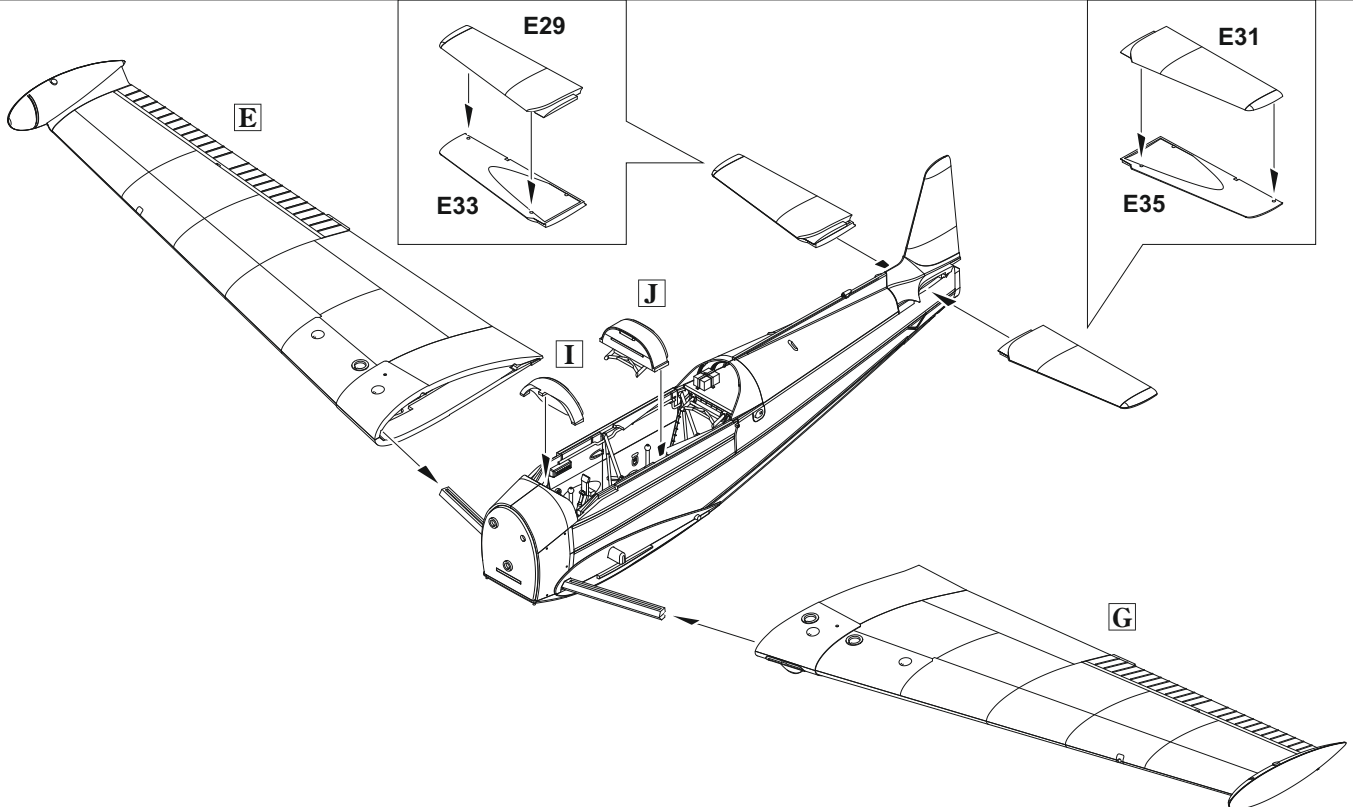
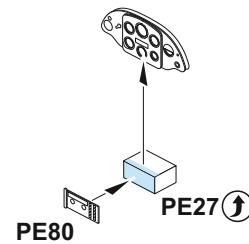
MARKING **A**MARKING **C**MARKING **D**MARKINGS **H, I**MARKING **H**

K MARKINGS **A, B, F, H, J**

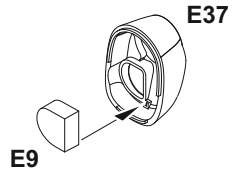
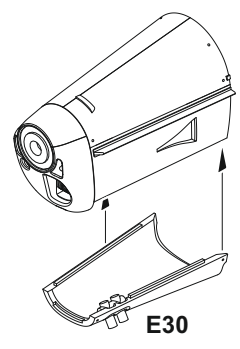
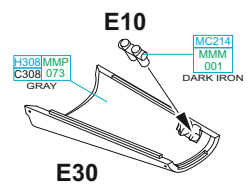
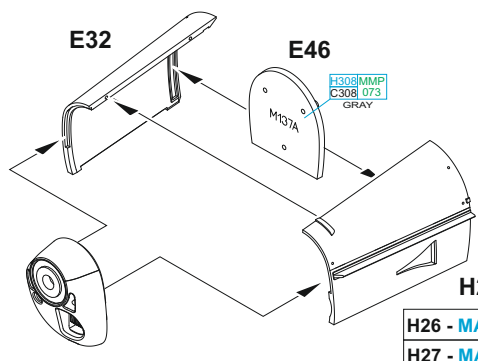
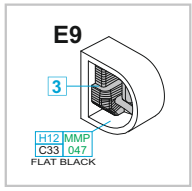

H26 - MARKINGS **F, J**
 H27 - MARKINGS **A, B, H**

MARKINGS **A1, C, D, E, G, I**

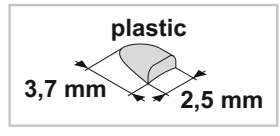
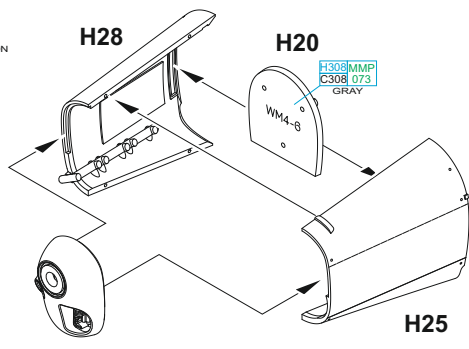
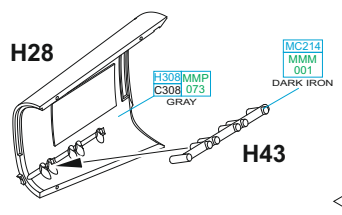
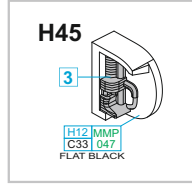

plastic - MARKING **E** ONLY

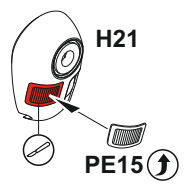
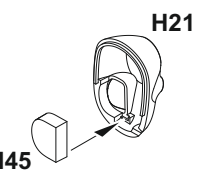
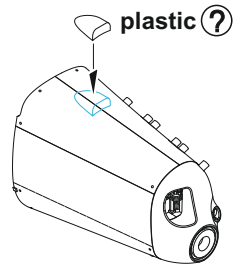

L 2 pcs.

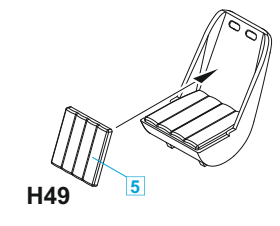
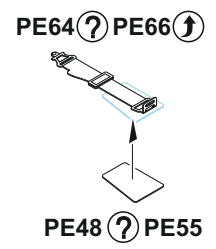
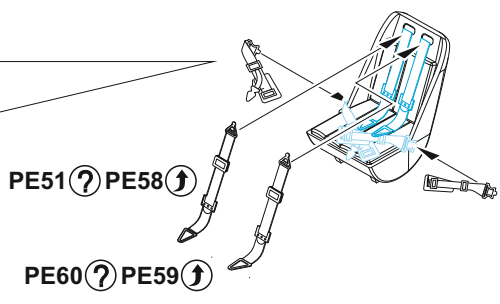
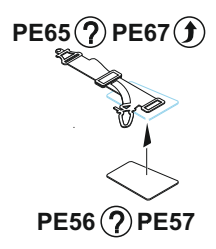
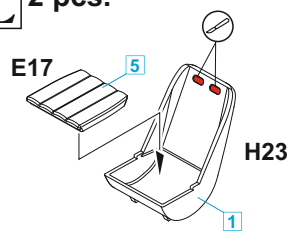

H31 - MARKINGS **E, I** ONLY

H31 ? E34

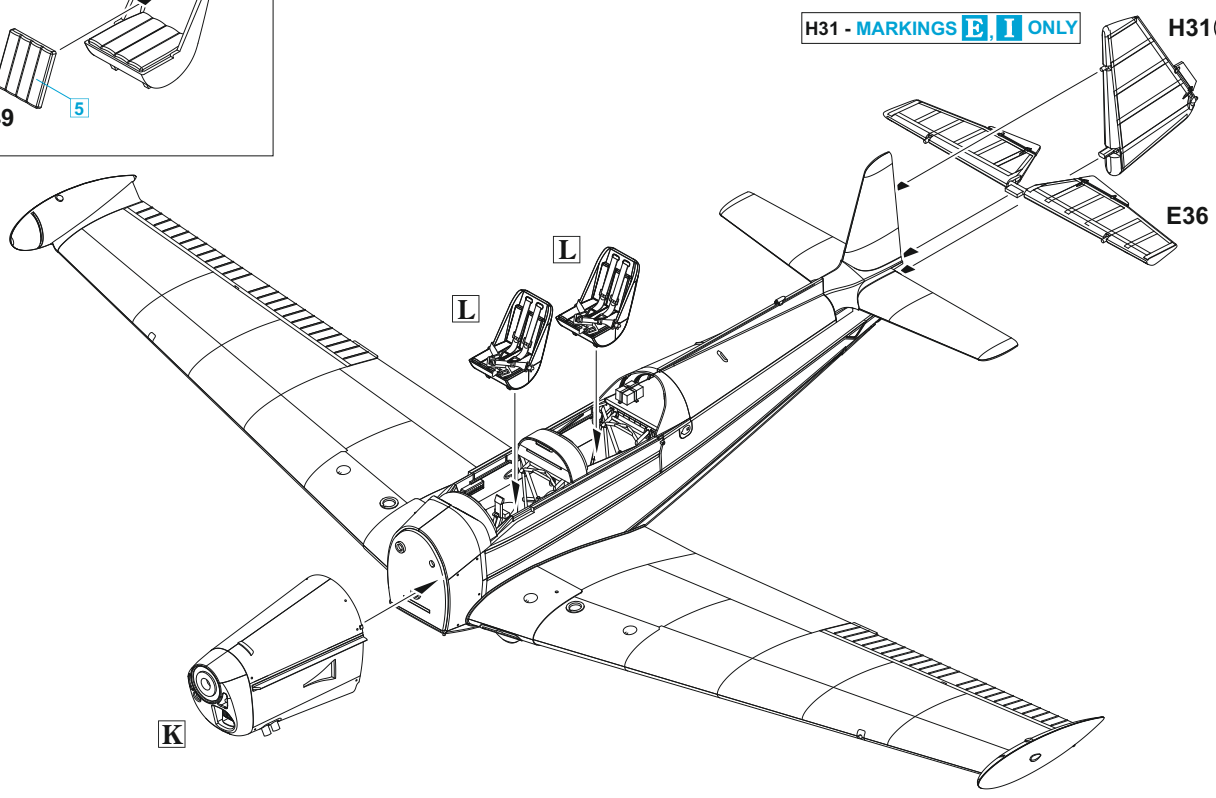

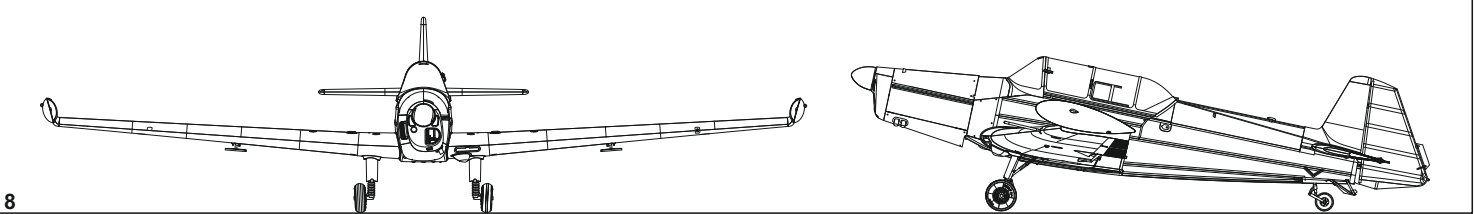
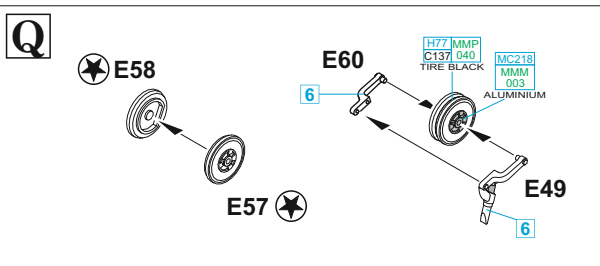
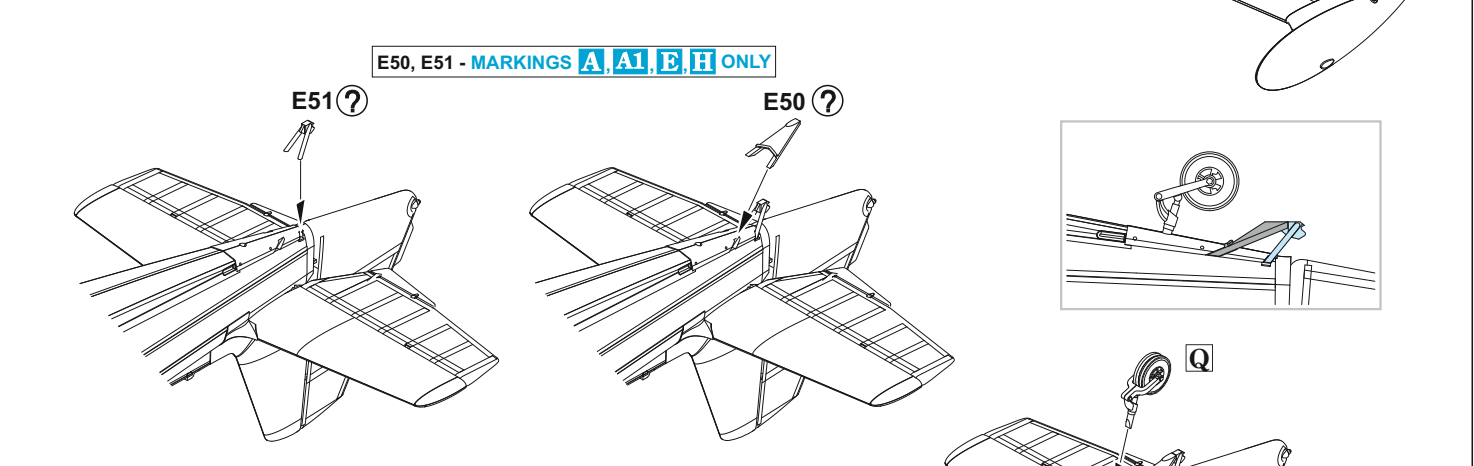
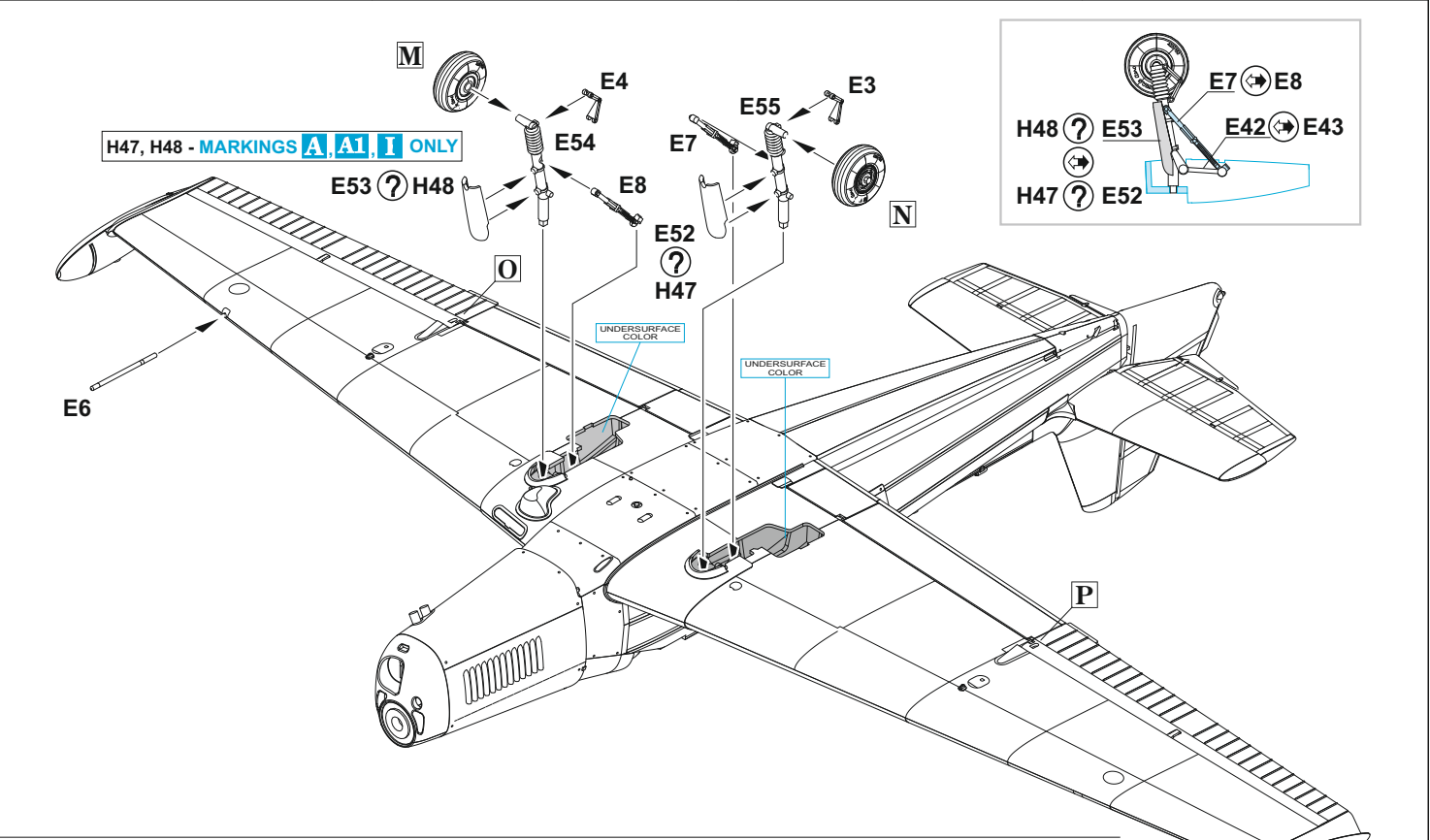
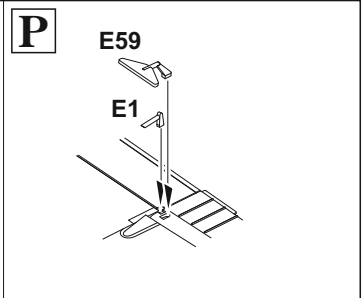
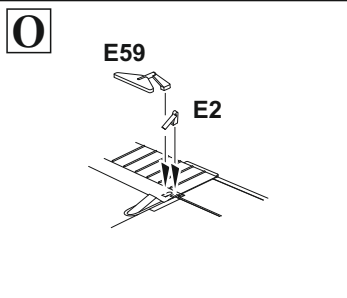
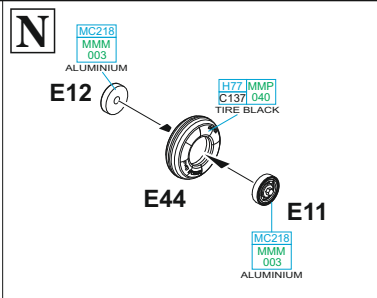
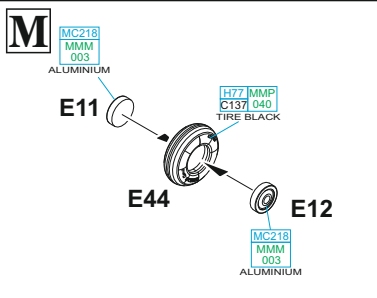

R MARKINGS **A1, C, D, E, G, I**

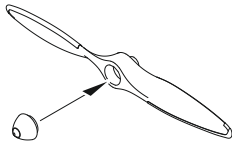

J16 J14 ? J15

J14 - MARKINGS **A1, C, E, I**

J15 - MARKINGS **D, G**

MARKINGS **A, H**

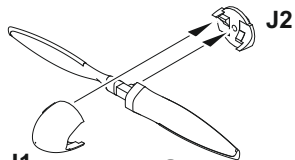

J1 J12 ? J13

J12 - MARKING **H**

J13 - MARKING **A**

MARKINGS **B, F, J**

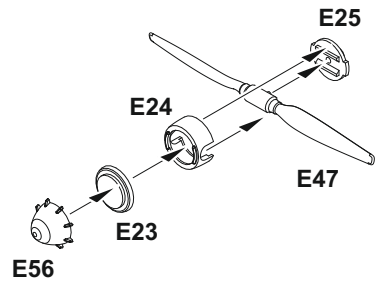

E25

E24

E23

E47

S

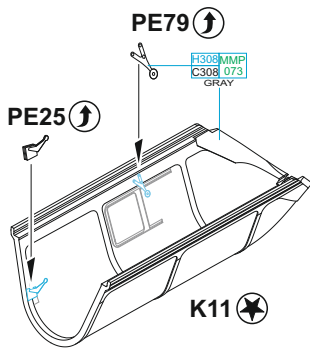

PE79 ↑

PE25 ↑

K11 ⬆

H308 MMP
C308 073
GRAY

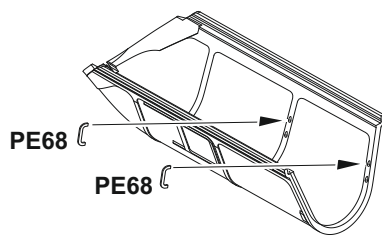

PE68

PE68

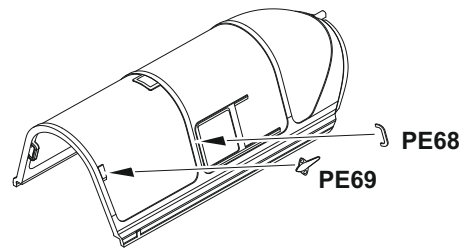

PE68

PE69

T

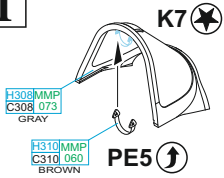

K7 ⬆

PE5 ↑

H308 MMP
C308 073
GRAY

H310 MMP
C310 060
BROWN

PE75 - MARKING **H** ONLY



? ↑ PE75

H2 MMP
C2 047
BLACK

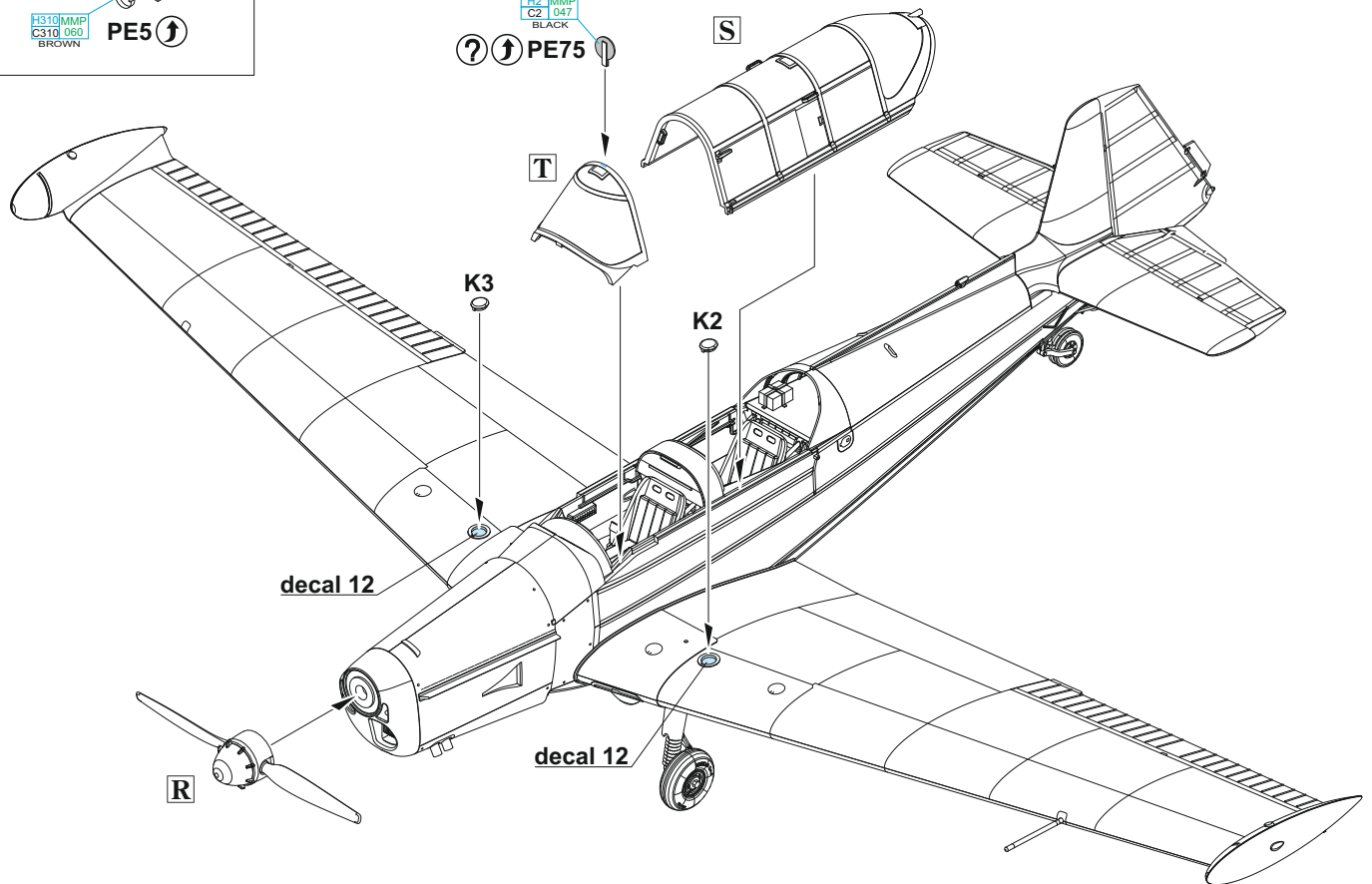

decal 12

decal 12

R

?

OPEN CANOPY

S

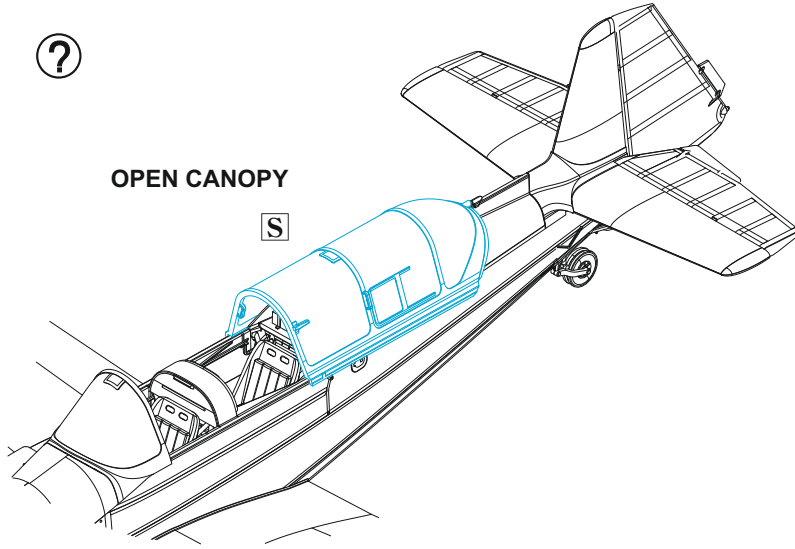

eduard
MASK

11167 A

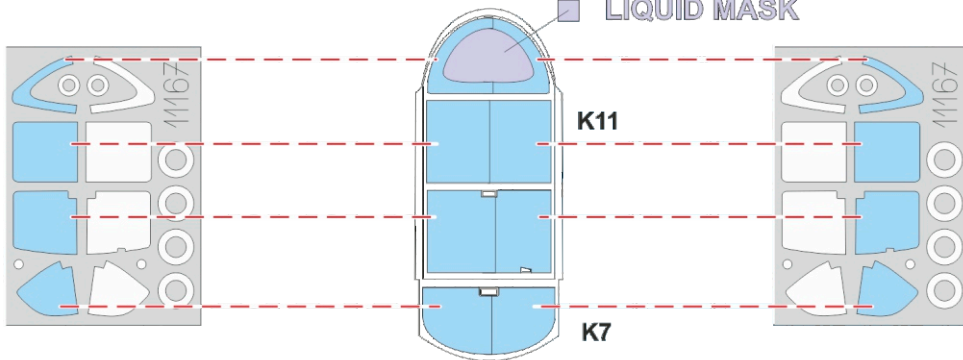
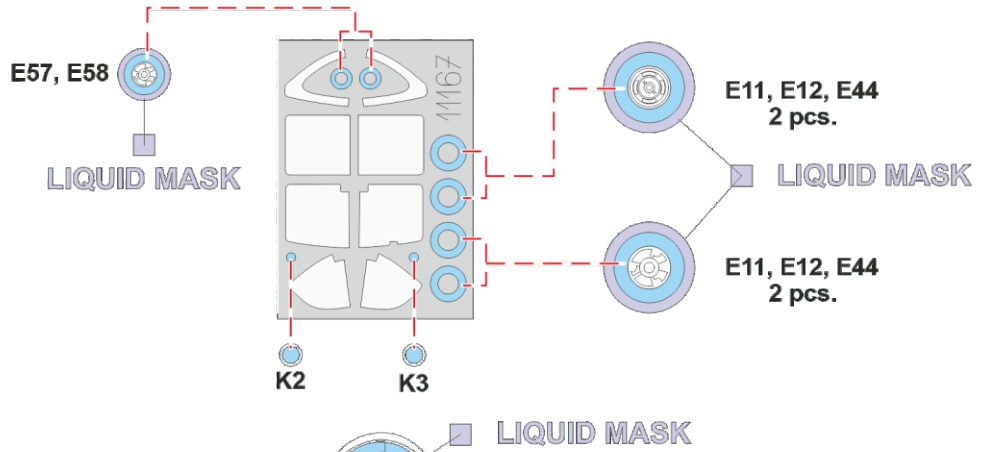

eduard
MASK

11167 B

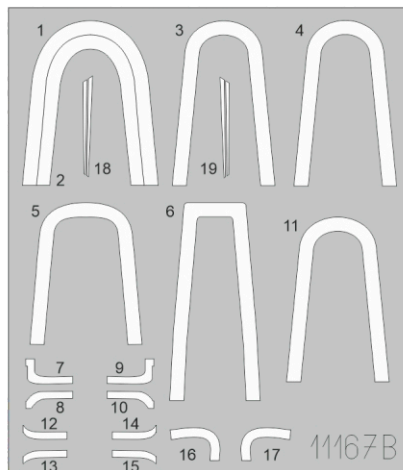

A Z-326M, No. 612, private owner, Točná airfield, Czech Republic, summer 2022

The ČSLA (Czechoslovak Air Force) took delivery of ten C-305s, the military modification of the Z-326. It was handed over to the Army on December 14, 1960. During the service it underwent two overhauls, the second one was completed just seven days before the handover to the Prievidza Aero Club on July 29, 1971. There the A/C received the matriculation OK-OTP and on December 29, 1979, it was converted to the Z-326M standard by installation of the M-137 engine. It stayed in Prievidza after the dissolution of Czechoslovakia with the Slovak matriculation OM-OTP. The aircraft made its last flight in red, white and black paint on May 25, 2008, when the crew Jánošík/Chupek flew it from Prievidza to the new owner. The aircraft was to be hung from the ceiling of a private museum and the green paint was planned to imitate Bf 109. Before the wing spars could be irreversibly damaged, as it was planned to anchor the cables to them, the A/C was purchased and transported to Prague by Karel Toman. He planned to bring it back to airworthy condition. In 2012 the project was taken over by Milan Mikulecký. After a complete overhaul by Zlin-Avion Service, the aircraft received some military equipment and paintwork according to the factory drawing for C-305. According to contemporary documentation and testimonies, the 0612 was delivered in this livery, but only photographs of simple silver paint finish are known. The alternative marking 0610 can be used to build historically documented C-305 in these colors.

COL A1
Use decals 8 & 217
Do not use decals 4; 5 & 6
For propeller see marking I

ČESKOU VERZI TEXTU NALEZNETE NA
www.eduard.com
POD KATALOGOVÝM ČÍSLEM 11167

WOOD BROWN	H37 C43	SKY BLUE	C34	BRIGHT BLUE	C65	BLACK	H2 C2	MMP C2	O47		
SUPER SILVER	C159	METALLIC BLUE GREEN	C57	LIGHT BLUE	C118	INTERIOR GREEN	C391	WHITE	H1 C1	MMP C1	O01
						YELLOW	H413 C113	MMP C113	O90	COPPER	MC215 MMM O04

B Z-326MF, No. 925, private owner, Yverdon, Switzerland, 2018

The aircraft from the last production run of Z-326 is one of those exported to France. There it received the F-BORV matriculation in 1967. After retirement from service in France it was put into storage for some time and later sold to a private owner in Switzerland. There it was repaired and operated in a new livery, but with the original powerplant. In 2015 and 2016 the aircraft was converted by Zlin-Avion Service to the Z-326MF version and returned to its home base in Yverdon consequently. The livery evokes the look of American Navy aircraft from the 1930s.

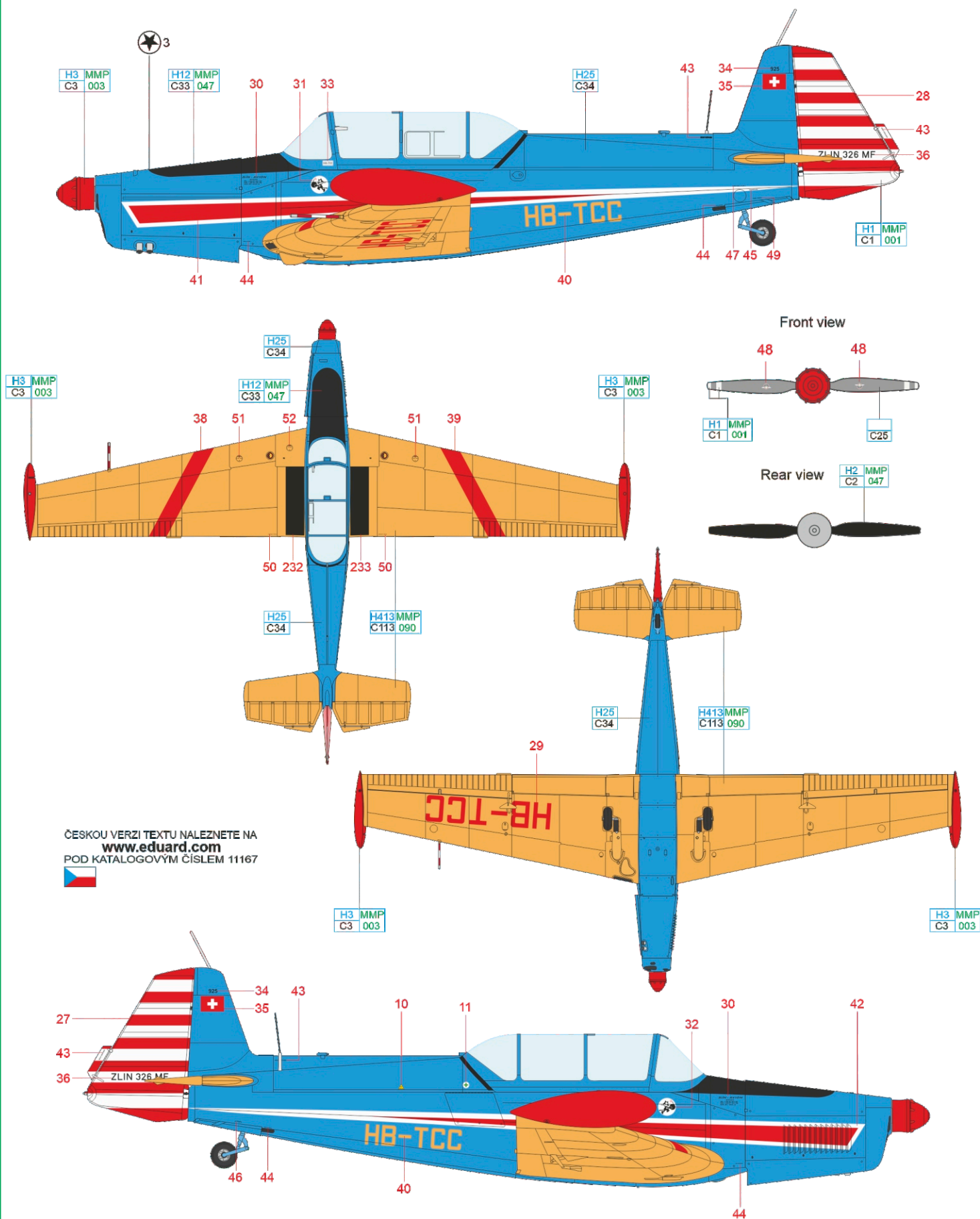

ČESKOU VERZI TEXTU NALEZNETE NA
www.eduard.com
 POD KATALOGOVÝM ČÍSLEM 11167



- YELLOW H413 MMP C113 090
- RED H3 MMP C3 003
- SKY BLUE H25 C34
- WHITE H1 MMP C1 001
- BLACK H12 MMP C33 047
- SEAGRAY C25
- BLACK H2 MMP C2 047

This Z-326 became the first ever aerobatic aircraft in Iceland. It set off from Czechoslovakia to the island country on July 14, 1966, first by rail, then by ship. It has changed several owners in Iceland. Today, it is owned by Helgi Rafnsson. Among the pilots who put their hands on the controls of this aircraft is also one of Icelandic most famous pilots, Magnus Norðdahl. The former airline commercial pilot and DC-4 captain was born in 1928 and even after his 80th birthday he was still performing great aerobatics with TF-ABC including the famous "Lomcovac" on various occasions. The aircraft got an unusual livery in Iceland. The painting overlays all the stencilling; it was not restored. The number 168 on the vertical fin does not correspond to the serial number, as usual with other Treners.

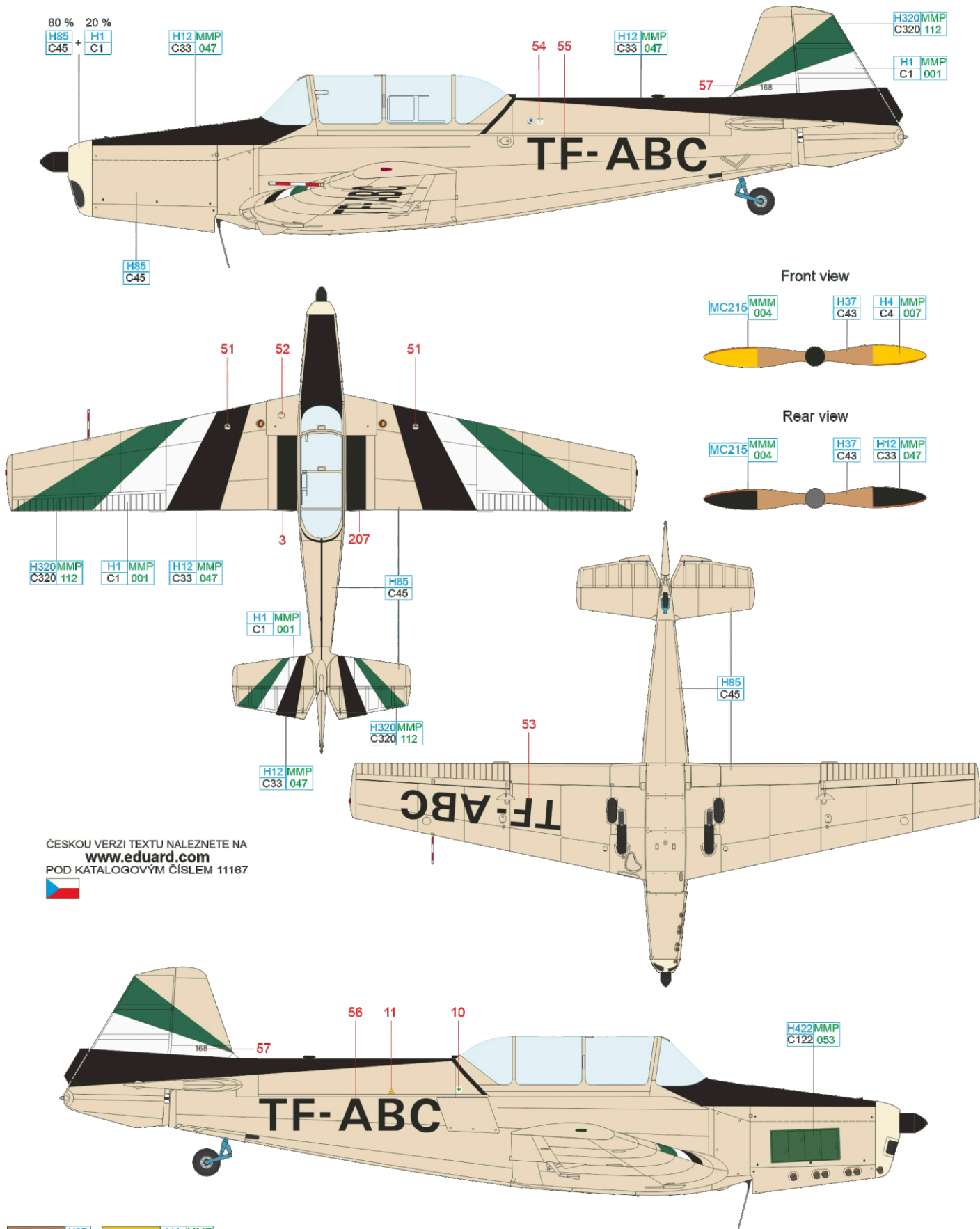

ČESKOU VERZI TEXTU NALEZNETE NA
www.eduard.com
 POD KATALOGOVÝM ČÍSLEM 11167



WOOD BROWN H37 C43 YELLOW H4 MMP C4 007

SAIL COLOR H85 C45 DARK GREEN H320 MMP C320 112 LIGHT GREEN H422 MMP C122 053

WHITE H1 MMP C1 001

BLACK H12 MMP C33 047

COPPER MC215 MMM 004

D Z-326, No. 933, Burdigala Flying Group, Bordeaux-Léognan-Saucats Aérodrome, France, 2016

A very unusually colored Z-326 flies from Bordeaux-Léognan-Saucats airport today. The owner is obviously a fan of Navy aircraft and so he painted and decorated his Trener in this spirit. The aircraft was handed over to the CNVM (Centro Nacional de Verificación de Maquinaria) in Spain in 1968. From there it was later sold to the French owner. It was flown by the Picardie-Amiens Aero Club and is operated by the Burdigala Flying Group today. In addition to several unidentified air unit markings, the aircraft also sports various non-standard symbols.



ČESKOU VERZI TEXTU NALEZNETE NA
www.eduard.com
 POD KATALOGOVÝM ČÍSLEM 11167



The aircraft was produced in 1963 and sold to Germany on January 5, 1965. It received the D-EFAI matriculation, after some time it was sold to Sweden (where it flew as SE-CWK), but later returned to Germany. Subsequent changes of owners took the aircraft first to France and then back to Germany again... In Germany the aircraft continued to operate with the original German matriculation. From 1984 to 1993 it was owned by Dietmar Metz, now a member of the Dragon Trener Team. Dietmar started his aerobatic career flying the D-EFAI. Today, this Trener Master has a new owner and a new livery, which includes also a small Czech cockade.

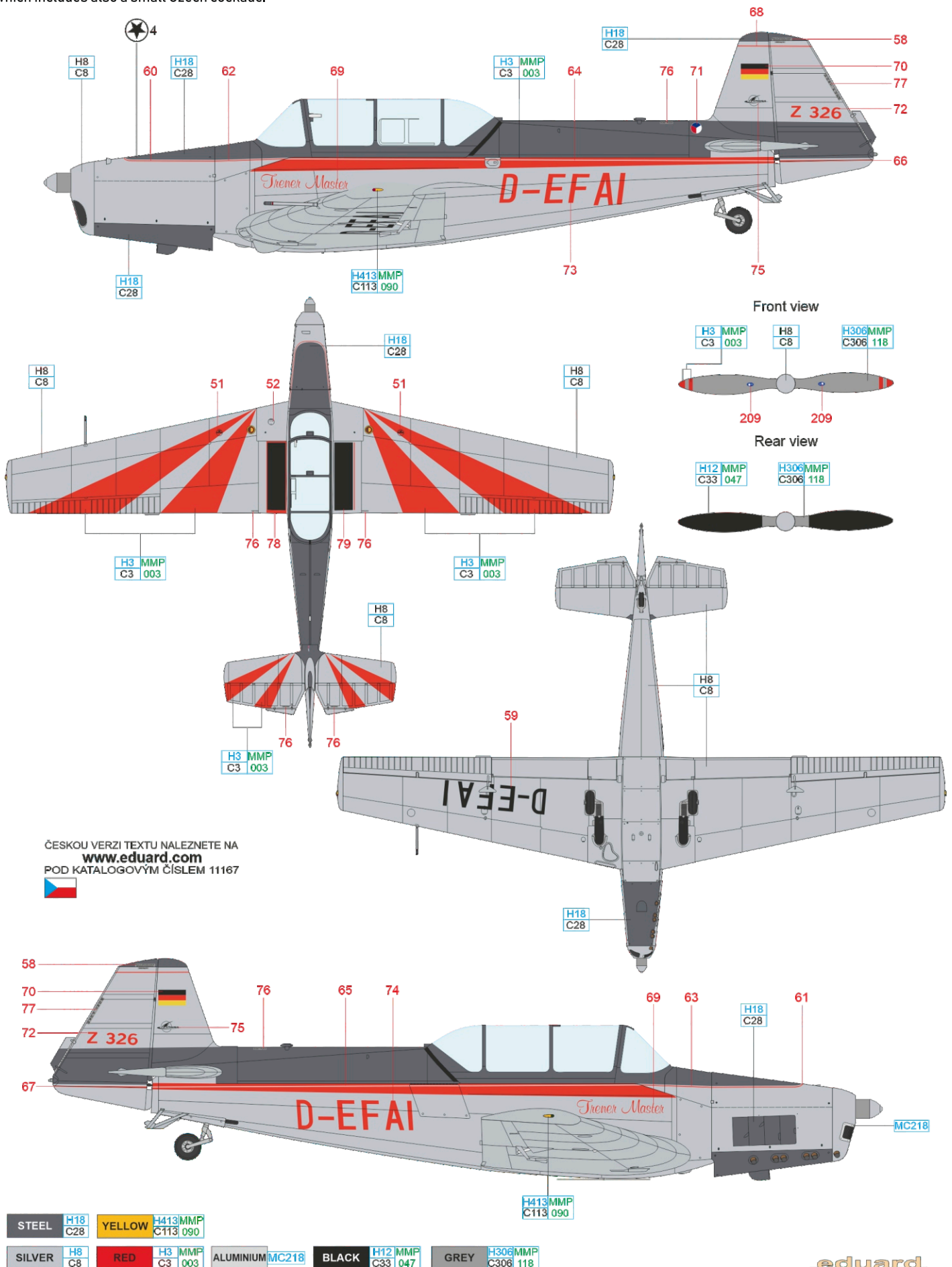

F Z-326MF, No. 861, Fundació Parc Aeronàutic de Catalunya, Barcelona-Sabadell, Spain, 2005

The first Trener Master exported to Spain was the one with the serial number 861. Manufactured in 1962, it was sold to Spain on April 29, 1964, and obtained the EC-WXA matriculation. The aircraft served with the Spanish National Aerobatic Team as the first Z-326. The team won the 1964 World Championships in Bilbao. Subsequently, the aircraft was grounded for several years. In the 1990s, members of the Foundation at Barcelona-Sabadell Airport attempted to repair it to airworthy condition, but eventually it was transported to Zlin-Avion Service in 2002 for complete overhaul and conversion to the Z-326MF standard. It was all completed in 2003. Since then, it has been operated by the Sabadell Airport Foundation, now with the EC-AXA matriculation.

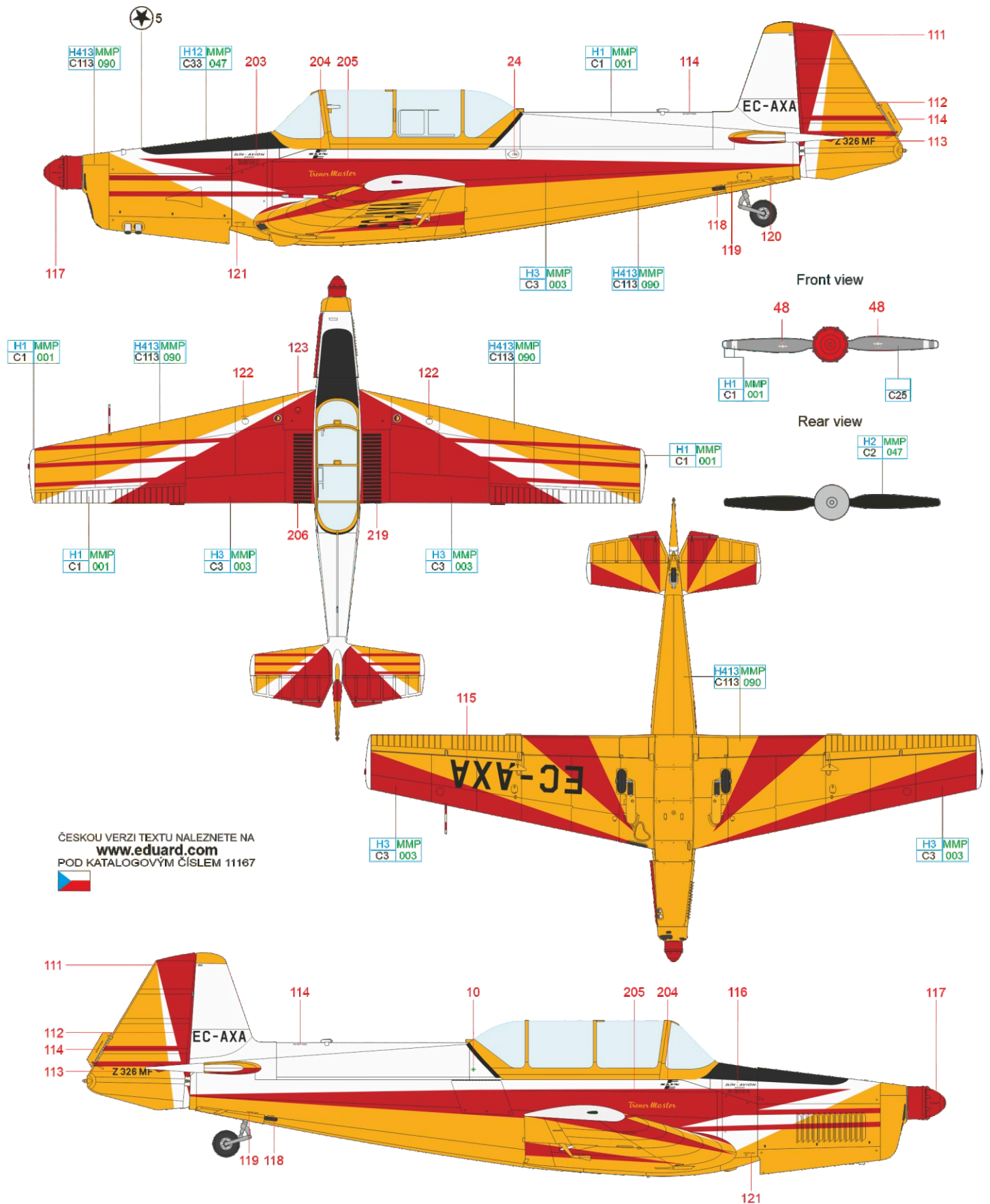

ČESKOU VERZI TEXTU NALEZNETE NA
www.eduard.com
 POD KATALOGOVÝM ČÍSLEM 11167



YELLOW H413MMP C113 090 RED H3 MMP C3 003 WHITE H1 MMP C1 001 BLACK H12 MMP C33 047 SEAGRAY C25 BLACK H2 MMP C2 047

eduard

This Trener Master was originally exported to Portugal, where it flew with CS-ALU matriculation and was reportedly tested by the Air Force for possible pilot training usage. It was later grounded and stored for several years before being purchased by Henry Labouchere. The aircraft was said to have flown only eight hours at that time! On the flight to the UK, the new owner was arrested in Spain and spent the night in prison in Breganza. This reportedly happened due to the fact that all the A/C documents, including insurance ones, expired. In 1982 the aircraft was bought by Roger Charles Poolman, and from 1988 until 2000 it was in possession of the Nimrod Group of Cheltenham. The next owner was Peter Colman, who undertook an extensive refurbishment of the aircraft. Since 2017 the owner has been Tim Cooper, who keeps flying it from Chichester airfield in the southern England region.



ČESKOU VERZI TEXTU NALEZNETE NA
www.eduard.com
 POD KATALOGOVÝM ČÍSLEM 11167



BLUE	H35 C80	BLUE	H5 C5	WHITE	H1 MMP C1 001	BLACK	H12 MMP C33 047	BLUE	H418 MMP C118 055	GRAY	H306 MMP C306 118
------	------------	------	----------	-------	------------------	-------	--------------------	------	----------------------	------	----------------------

eduard

This aircraft is serving with the Prostějov Aero Club, which is proudly bearing the name of the most famous Czechoslovak WWII fighter pilot Josef František, a native of nearby Otaslavice. The aircraft itself bears a proud name as well, as the aeroclub members named it after its predominantly red coloring "the Red Baron". The aircraft is mainly used for sailplane towing, which is the task in which it replaced its predecessors Z-226 OK-MQB and OK-KMS. However, it began its career much earlier as a military C-305 with fuselage code 0604. It was entered to the civil register on May 8, 1968, and was assigned first to Prague, then to Vrchlabí Aero Club. Later it was moved to the regional Aero Club Olomouc and consequently to Prostějov.

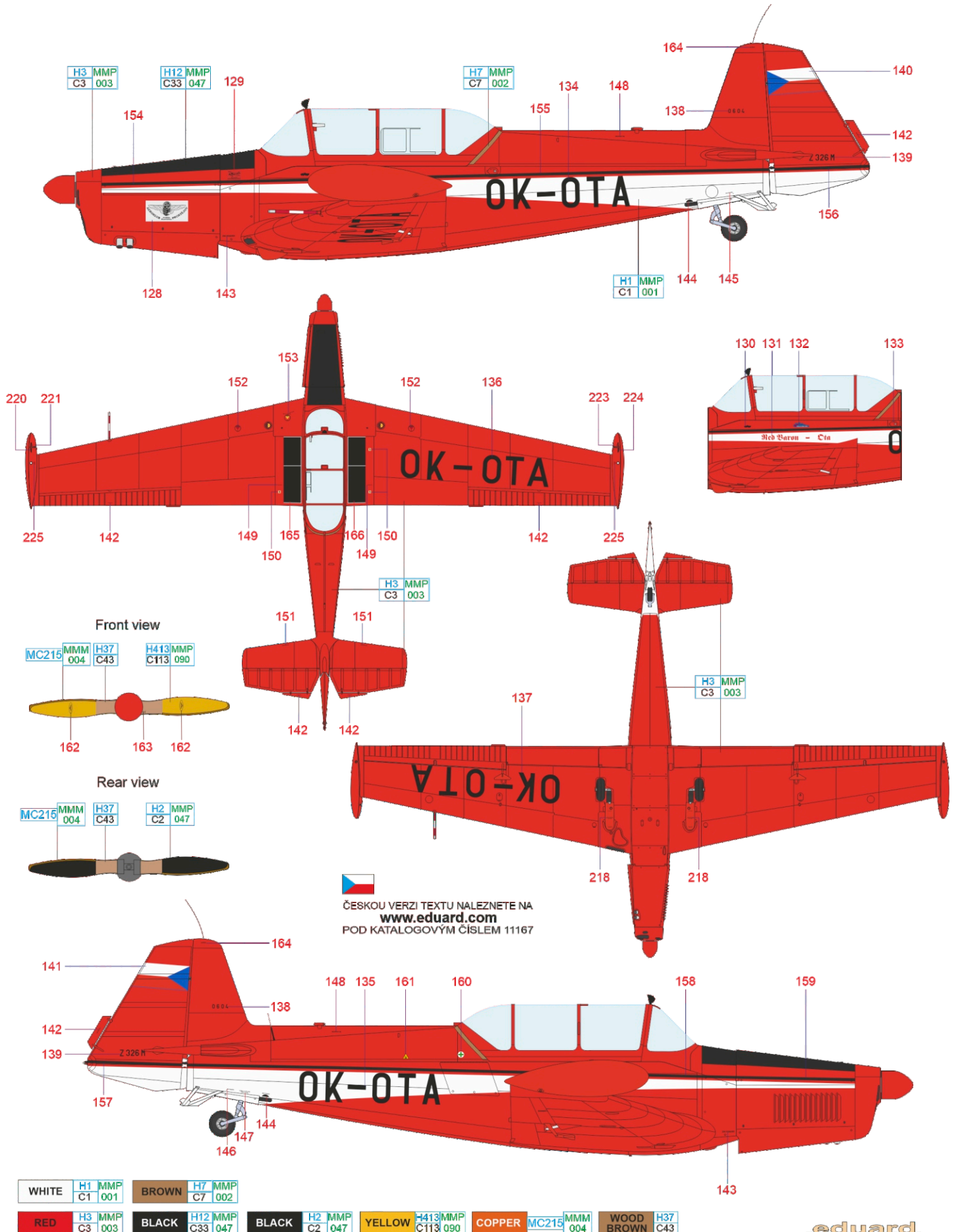

Z-326MF, No. 931, private owner, Slaný airfield, Czech Republic, 2022

This aircraft was manufactured in 1967 and at the end of October of the same year it was flown to the factory warehouse in Vyškov, where it remained until April 1968. It was then sold to France and flown there on July 11, 1968. In France, it received the F-BPNP matriculation and flew as a trainer and towing aircraft for ten years at Carcassonne airfield in southern France region. From 1979 this A/C served to flight school at Nîmes airport but was moved by ship to the Caribbean in November 1983. There its new owner flew it from Pointe-à-Pitre airport in Guadeloupe. From September 1985 to August 1988 the F-BPNP was stored and did not fly, the exception were last few flights at the turn of 1988/89. It changed hands several times over the next twenty years but did not fly at all. In 2008 it returned to the Otrokovice in Czech Republic and underwent an overhaul by Zlin-Avion Service as well as conversion to the Z-326MF standard. The FTO Aviatický klub (Aviatic Club) from Roudnice n/L became the operator of the aircraft, but it is also employed by Vintage Aviation for pilot training. The aircraft's livery has a historical context. In the 1960s and 1970s, the aerobatic team of Great Britain led by Neil Williams flew Z-226s and Z-526s in the same colors.

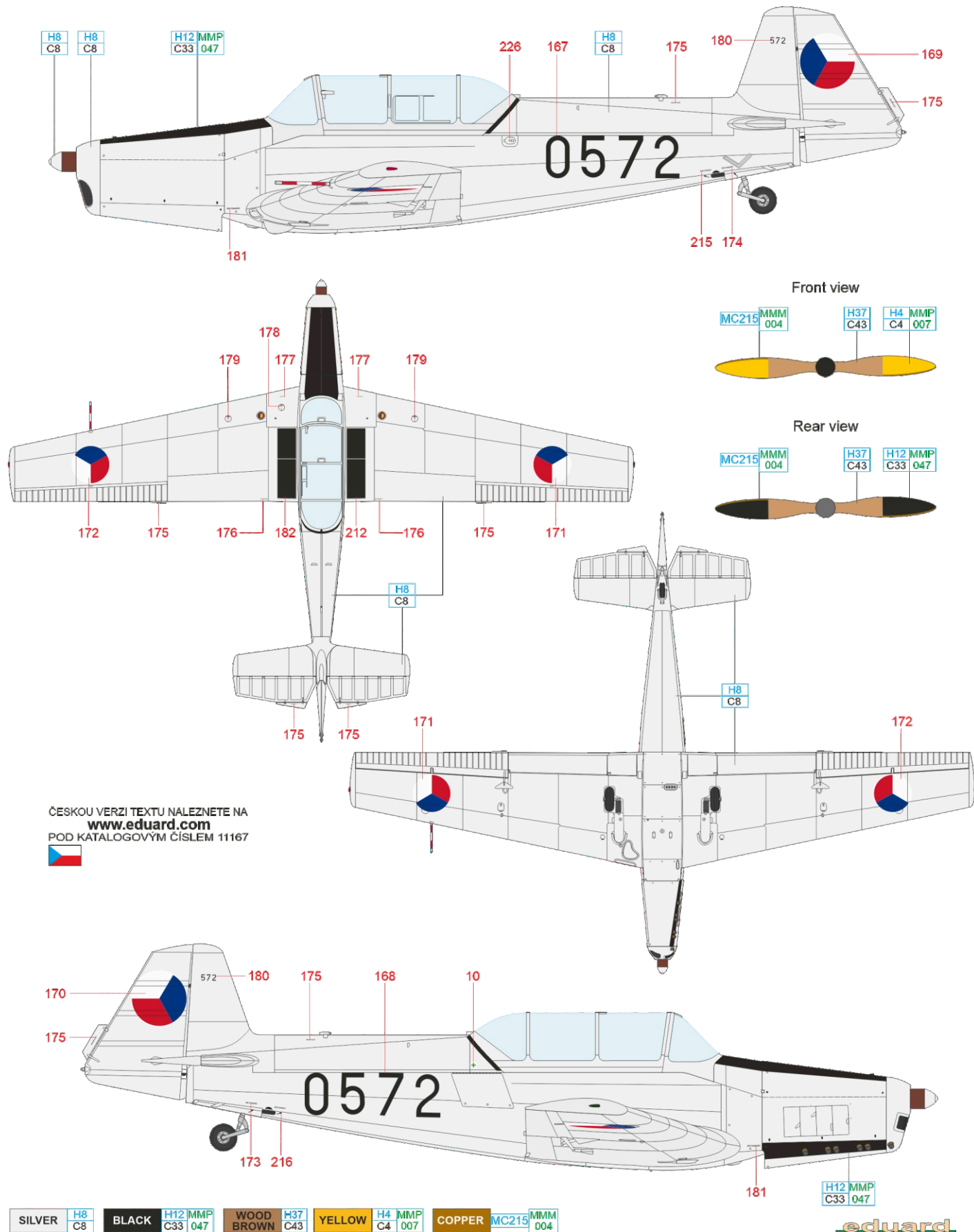

J Z-326MF, No. 931, private owner, Slaný airfield, Czech Republic, 2022

This aircraft was manufactured in 1967 and at the end of October of the same year it was flown to the factory warehouse in Vyškov, where it remained until April 1968. It was then sold to France and flown there on July 11, 1968. In France, it received the F-BPNP matriculation and flew as a trainer and towing aircraft for ten years at Carcassonne airfield in southern France region. From 1979 this A/C served to flight school at Nîmes airport but was moved by ship to the Caribbean in November 1983. There its new owner flew it from Pointe-à-Pitre airport in Guadeloupe. From September 1985 to August 1988 the F-BPNP was stored and did not fly, the exception were last few flights at the turn of 1988/89. It changed hands several times over the next twenty years but did not fly at all. In 2008 it returned to the Otrokovice in Czech Republic and underwent an overhaul by Zlin-Avion Service as well as conversion to the Z-326MF standard. The FTO Aviatický klub (Aviatic Club) from Roudnice n/L became the operator of the aircraft, but it is also employed by Vintage Aviation for pilot training. The aircraft's livery has a historical context. In the 1960s and 1970s, the aerobatic team of Great Britain led by Neil Williams flew Z-226s and Z-526s in the same colors.

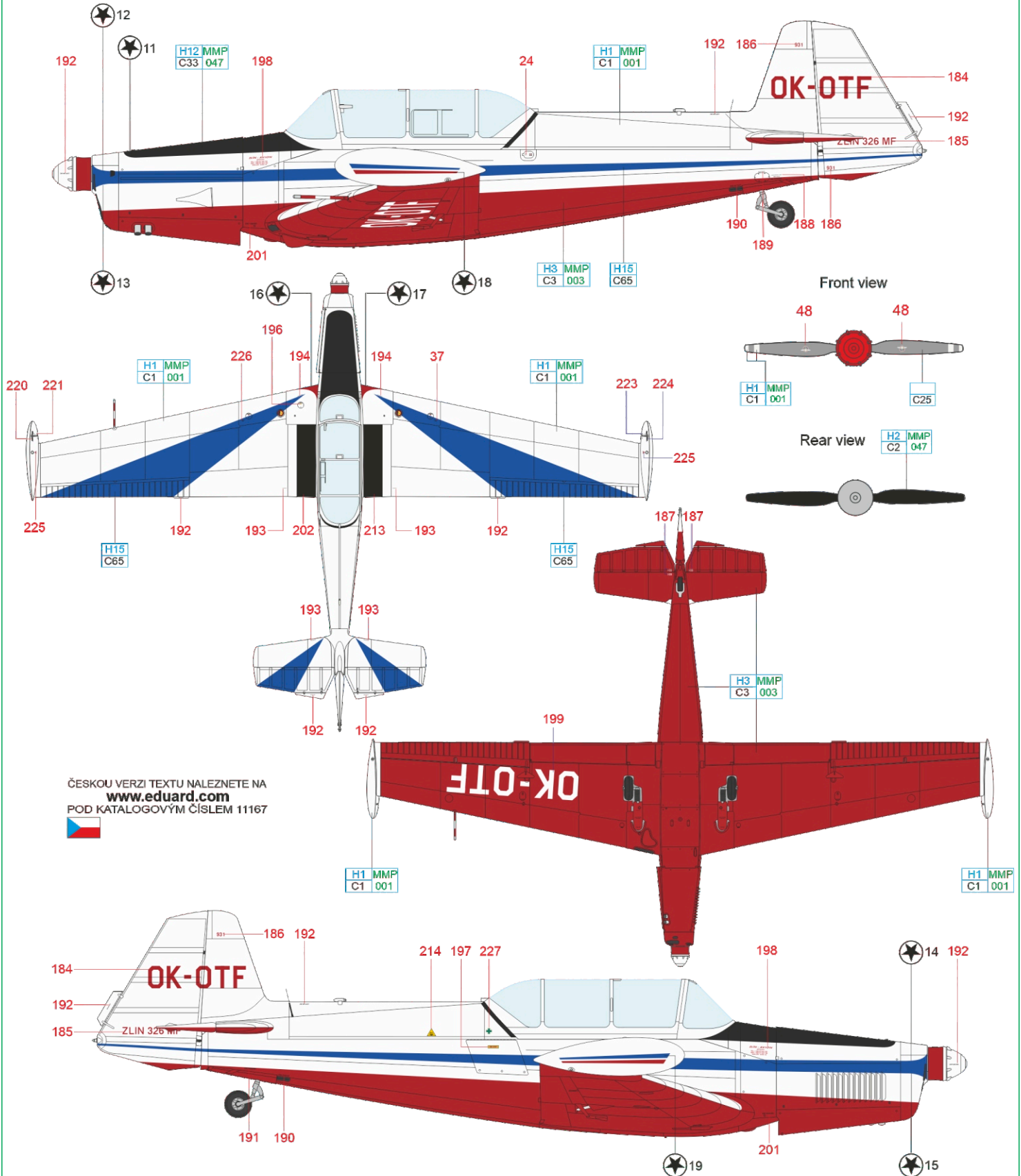

ČESKOU VERZI TEXTU NALEZNETE NA
www.eduard.com
 POD KATALOGOVÝM ČÍSLEM 11167



BLUE H15 C65 RED H3 MMP C3 003 WHITE H1 MMP C1 001 BLACK H12 MMP C33 047 SEAGRAY C25 BLACK H2 MMP C2 047

